



General-Purpose AC Servo

MITSUBISHI SERVO AMPLIFIERS & MOTORS

MELSERVO-J4

Power Regeneration Converter Unit

MODEL

MR-CV_

Resistance Regeneration Converter Unit

MODEL

MR-CR55K_

SSCNET /H Interface Drive Unit

MODEL

MR-J4-DU_B_(-RJ)

General-Purpose Interface Drive Unit

MODEL

MR-J4-DU_A_(-RJ)

INSTRUCTION MANUAL

● Safety Instructions ●

Please read the instructions carefully before using the equipment.

To use the equipment correctly, do not attempt to install, operate, maintain, or inspect the equipment until you have read through this Instruction Manual, Installation guide, and appended documents carefully. Do not use the equipment until you have a full knowledge of the equipment, safety information and instructions. In this Instruction Manual, the safety instruction levels are classified into "WARNING" and "CAUTION".



Indicates that incorrect handling may cause hazardous conditions, resulting in death or severe injury.



Indicates that incorrect handling may cause hazardous conditions, resulting in medium or slight injury to personnel or may cause physical damage.

Note that the  CAUTION level may lead to a serious consequence depending on conditions.

Please follow the instructions of both levels because they are important to personnel safety.

What must not be done and what must be done are indicated by the following diagrammatic symbols.



Indicates what must not be done. For example, "No Fire" is indicated by .



Indicates what must be done. For example, grounding is indicated by .

In this Instruction Manual, instructions at a lower level than the above, instructions for other functions, and so on are classified into "POINT".

After reading this Instruction Manual, keep it accessible to the operator.

1. To prevent electric shock, note the following

WARNING

- Before wiring, turn off the power and wait for 20 minutes or more until the charge lamp turns off. Then, confirm that the voltage between L+ and L- is safe with a voltage tester or others. Otherwise, an electric shock may occur. In addition, when confirming whether the charge lamp is off or not, be sure to look at the lamp from the front of the converter unit.
- Ground the converter unit, drive unit, and servo motor securely.
- Any person who is involved in wiring and inspection should be fully competent to do the work.
- Do not attempt to wire the converter unit, drive unit, and servo motor until they have been installed. Otherwise, it may cause an electric shock.
- Do not operate switches with wet hands. Otherwise, it may cause an electric shock.
- The cables should not be damaged, stressed, loaded, or pinched. Otherwise, it may cause an electric shock.
- During power-on or operation, do not open the front cover of the converter unit and the drive unit. Otherwise, it may cause an electric shock.
- Do not operate the converter unit and the drive unit with the front cover removed. High-voltage terminals and charging area are exposed and you may get an electric shock.
- Except for wiring or periodic inspection, do not remove the front cover of the converter unit and the drive unit even if the power is off. The converter unit and the drive unit are charged, and you may get an electric shock.
- To prevent an electric shock, be sure to connect the protective earth (PE) terminal (marked \oplus) of the converter unit and the drive unit to the protective earth (PE) of the cabinet.
- To avoid an electric shock, insulate the connections of the power supply terminals.

2. To prevent fire, note the following

CAUTION

- Install the converter unit, the drive unit, the servo motor, and the regenerative resistor on incombustible material. Installing them directly or close to combustibles will lead to smoke or a fire.
- Be sure to connect a magnetic contactor between the power supply and the main circuit power supply (L1/L2/L3) of the converter unit, in order to configure a circuit that shuts off the power supply by the magnetic contactor. If the magnetic contactor is not connected, a continuous flow of a large current may cause smoke or a fire when the converter unit or the drive unit malfunctions.
- Be sure to connect a magnetic contactor for each converter unit between the power supply and the main circuit power supply (L1/L2/L3) of the converter unit, in order to configure a circuit that shuts off the power supply by the magnetic contactor. If a molded-case circuit breaker or fuse is not connected, a continuous flow of a large current may cause smoke or a fire when the converter unit malfunctions.
- When using the regenerative resistor, shut the power off with an alarm signal. Otherwise, a regenerative transistor malfunction or the like may overheat the regenerative resistor, causing smoke or a fire.
- Provide adequate protection to prevent screws and other conductive matter, oil and other combustible matter from entering the converter unit, the drive unit, and the servo motor.

3. To prevent injury, note the following

CAUTION

- Only the power/signal specified in the Instruction Manual should be applied to each terminal. Otherwise, it may cause an electric shock, fire, injury, etc.
- Connect cables to the correct terminals. Otherwise, a burst, damage, etc., may occur.
- Ensure that polarity (+/-) is correct. Otherwise, a burst, damage, etc., may occur.
- The heat sink of the converter unit and drive unit, the regenerative resistor, the servo motor, etc. may be hot while power is on and for some time after power-off. Take safety measures such as providing covers to avoid accidentally touching them by hands and parts such as cables.

4. Additional instructions

The following instructions should also be fully noted. Incorrect handling may cause a malfunction, injury, electric shock, fire, etc.

(1) Transportation and installation

CAUTION

- Transport the products correctly according to their mass.
- Use the eyebolts of the converter unit and of the drive unit only for transporting. Do not use the eyebolts for transporting with the converter unit and the drive unit mounted on a machine.
- Do not overtighten the eyebolts of the converter unit and of the drive unit. Tightening too hard may damage the tap.
- Stacking in excess of the specified number of product packages is not allowed.
- Do not hold the front cover, cables, or connectors when carrying the converter unit and drive unit. Otherwise, it may drop.
- Install the converter unit, the drive unit, and the servo motor in a load-bearing place in accordance with the Instruction Manual.
- Do not get on or put heavy load on the product. Otherwise, it may cause injury.
- The equipment must be installed in the specified direction.
- Maintain specified clearances between the converter unit/drive unit and the inner surfaces of a control cabinet or other equipment.
- Do not install or operate the converter unit, the drive unit, and the servo motor which have been damaged or have any parts missing.
- Do not block the intake and exhaust areas of the converter unit and the drive unit. Otherwise, it may cause a malfunction.
- Do not drop or apply heavy impact on the converter units, the drive units, and the servo motors. Otherwise, it may cause injury, malfunction, etc.
- Do not strike the connector. Otherwise, it may cause a connection failure, malfunction, etc.
- When you keep or use the equipment, please fulfill the following environment.

Item		Environment
Ambient temperature	Operation	0 °C to 55 °C (non-freezing)
	Storage	-20 °C to 65 °C (non-freezing)
Ambient humidity	Operation	5 %RH to 90 %RH (non-condensing)
	Storage	
Ambience		Indoors (no direct sunlight), free from corrosive gas, flammable gas, oil mist, dust, and dirt
Altitude		2000 m or less above sea level (Contact your local sales office for the altitude for options.)
Vibration resistance		5.9 m/s ² , at 10 Hz to 55 Hz (X, Y, Z axes)

- When the product has been stored for an extended period of time, contact your local sales office.
- When handling the converter unit and the drive unit, be careful with the sharp edges of the converter unit and drive unit.
- The converter unit and the drive unit must be installed in a metal cabinet.
- When fumigants that contain halogen materials, such as fluorine, chlorine, bromine, and iodine, are used for disinfecting and protecting wooden packaging from insects, they cause a malfunction when entering our products. Please take necessary precautions to ensure that remaining materials from fumigant do not enter our products, or treat packaging with methods other than fumigation, such as heat treatment. Additionally, disinfect and protect wood from insects before packing the products.
- To prevent a fire or injury in case of an earthquake or other natural disasters, securely install, mount, and wire the servo motor in accordance with the Instruction Manual.

(2) Wiring

⚠ CAUTION

- Wire the equipment correctly and securely. Otherwise, the servo motor may operate unexpectedly.
- Make sure to connect the cables and connectors by using the fixing screws and the locking mechanism. Otherwise, the cables and connectors may be disconnected during operation.
- Do not install a power capacitor, surge killer, or radio noise filter (optional FR-BIF(-H)) on the drive unit output side.
- To avoid a malfunction of the servo motor, connect the wires to the correct phase terminals (U/V/W) of the drive unit and the servo motor.
- Connect the drive unit power outputs (U/V/W) to the servo motor power inputs (U/V/W) directly. Do not connect a magnetic contactor and others between them. Otherwise, it may cause a malfunction.

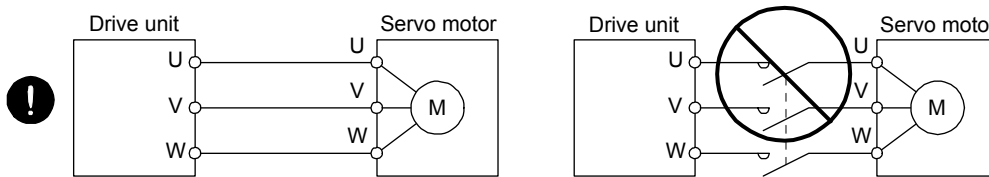

- The connection diagrams in this Instruction Manual are shown for sink interfaces, unless stated otherwise.
- Install the surge absorbing diode to the DC relay for control output signals in the converter unit and the drive unit in the specified direction. Otherwise, the converter unit and the drive unit will malfunction and will not output signals, disabling the emergency stop and other protective circuits.

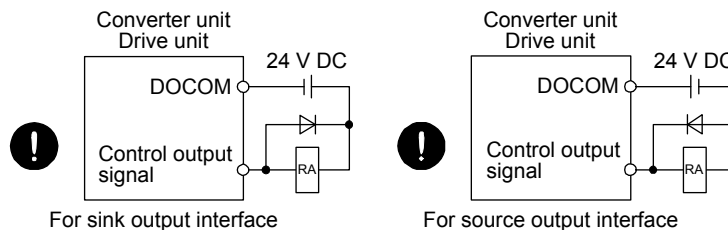

- When the wires are not tightened enough to the terminal block, the wires or terminal block may generate heat because of the poor contact. Be sure to tighten the wires with specified torque.
- Connecting a servo motor of the wrong axis to U, V, W, or CN2 of the drive unit may cause a malfunction.
- To prevent an unexpected restart of the drive unit, configure a circuit to turn off EM2 or EM1 when the main circuit power is turned off.
- To prevent malfunction, avoid bundling the power lines (input/output) of the converter unit and the signal cables together or running them in parallel to each other. Separate the power lines from the signal cables.

(3) Test run and adjustment

⚠ CAUTION

- When executing a test run, follow the notice and procedures in this instruction manual. Otherwise, it may cause a malfunction, damage to the machine, or injury.
- Before operation, check and adjust the parameter settings. Improper settings may cause some machines to operate unexpectedly.

CAUTION

- Never make a drastic adjustment or change to the parameter values as doing so will make the operation unstable.
- Do not get close to moving parts during the servo-on status.

(4) Usage

CAUTION

- For equipment in which the moving part of the machine may collide against the load side, install a limit switch or stopper to the end of the moving part. The machine may be damaged due to a collision.
- Do not disassemble, repair, or modify the product. Otherwise, it may cause an electric shock, fire, injury, etc. Disassembled, repaired, and/or modified products are not covered under warranty.
- Before resetting an alarm, make sure that the run signal of the drive unit is off to prevent a sudden restart. Otherwise, it may cause an accident.
- Use a noise filter, etc., to minimize the influence of electromagnetic interference. Electromagnetic interference may affect the electronic equipment used near the converter unit and the drive unit.
- Do not burn or destroy the converter unit and the drive unit. Doing so may generate a toxic gas.
- Use the converter unit and the drive unit with the specified servo motor.
- Correctly wire options and peripheral equipment, etc. in the correct combination. Otherwise, it may cause an electric shock, fire, injury, etc.
- The electromagnetic brake on the servo motor is designed to hold the motor shaft and should not be used for ordinary braking.
- For such reasons as incorrect wiring, service life, and mechanical structure (e.g. where a ball screw and the servo motor are coupled via a timing belt), the electromagnetic brake may not hold the motor shaft. To ensure safety, install a stopper on the machine side.
- If the dynamic brake is activated at power-off, alarm occurrence, etc., do not rotate the servo motor by an external force. Otherwise, it may cause a fire.

(5) Corrective actions

CAUTION

- Ensure safety by confirming the power off, etc. before performing corrective actions. Otherwise, it may cause an accident.
- If it is assumed that a power failure, machine stoppage, or product malfunction may result in a hazardous situation, use a servo motor with an electromagnetic brake or provide an external brake system for holding purpose to prevent such hazard.
- When an alarm occurs, eliminate its cause, ensure safety, and deactivate the alarm to restart operation.
- If the molded-case circuit breaker or fuse is activated, be sure to remove the cause and secure safety before switching the power on. If necessary, replace the converter unit and drive unit, and recheck the wiring. Otherwise, it may cause smoke, fire, or an electric shock.
- Provide an adequate protection to prevent unexpected restart after an instantaneous power failure.
- To prevent an electric shock, injury, or fire from occurring after an earthquake or other natural disasters, ensure safety by checking conditions, such as the installation, mounting, wiring, and equipment before switching the power on.

⚠ CAUTION

- Configure an electromagnetic brake circuit which is interlocked with an external emergency stop switch.

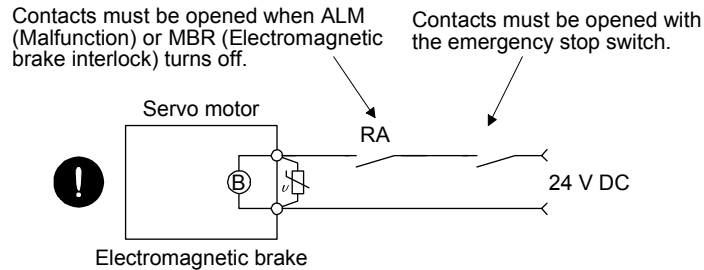

(6) Maintenance, inspection and parts replacement

⚠ CAUTION

- Make sure that the emergency stop circuit operates properly such that an operation can be stopped immediately and a power is shut off by the emergency stop switch.
- It is recommended that the converter unit and the drive unit be replaced every 10 years when it is used in general environment.
- When using a converter unit or a drive unit whose power has not been turned on for a long time, contact your local sales office.

(7) General instruction

- To illustrate details, the equipment in the diagrams of this Instruction Manual may have been drawn without covers and safety guards. When the equipment is operated, the covers and safety guards must be installed as specified. Operation must be performed in accordance with this Instruction Manual.

● DISPOSAL OF WASTE ●

Please dispose a servo amplifier and other options according to your local laws and regulations.

EEPROM life

The number of write times to the EEPROM, which stores parameter settings, etc., is limited to 100,000. If the total number of the following operations exceeds 100,000, the converter unit and the drive unit may malfunction when the EEPROM reaches the end of its useful life.

- Write to the EEPROM due to parameter setting changes
- Write to the EEPROM due to device changes
- Home position setting in the absolute position detection system (MR-J4-DU_A_(-RJ))

STO function of the drive unit

When using the STO function of the drive unit, refer to chapter 13 of "MR-J4-_A_(-RJ) Servo Amplifier Instruction Manual" or "MR-J4-_B_(-RJ) Servo Amplifier Instruction Manual".

For the MR-J3-D05 safety logic unit, refer to app. 5 of "MR-J4-_A_(-RJ) Servo Amplifier Instruction Manual" or "MR-J4-_B_(-RJ) Servo Amplifier Instruction Manual".

Compliance with global standards

Refer to section 10.2 for the compliance with global standards.

«About the manual»

You must have this Instruction Manual and the following manuals to use this servo. Be sure to prepare all the instruction manuals necessary to use the servo safely.

Power resistance regeneration converter units and resistance regeneration converter units are written as converter units in this manual under certain circumstances, unless otherwise stated.

Relevant manuals

Manual name	Manual No.
MELSERVO MR-J4- _A(-RJ) Servo Amplifier Instruction Manual (Note 1)	SH(NA)030107ENG
MELSERVO MR-J4- _B(-RJ) Servo Amplifier Instruction Manual (Note 2)	SH(NA)030106ENG
MR-J4- _A- RJ Servo Amplifier Instruction Manual (Positioning Mode) (Note 4)	SH(NA)030143ENG
MR-J4- _A- RJ Servo Amplifier Instruction Manual (Modbus RTU Protocol) (Note 5)	SH(NA)030175ENG
MELSERVO-J4 Servo Amplifier Instruction Manual (Troubleshooting)	SH(NA)030109ENG
MELSERVO Servo Motor Instruction Manual (Vol. 3)	SH(NA)030113ENG
MELSERVO Linear Servo Motor Instruction Manual (Note 6)	SH(NA)030110ENG
MELSERVO Linear Encoder Instruction Manual (Note 3)	SH(NA)030111ENG
MELSERVO EMC Installation Guidelines	IB(NA)67310ENG
MELSERVO MR-D30 Instruction Manual (Note 7)	SH(NA)030132ENG

- Note
1. It is necessary for using an MR-J4-DU_ _A_(-RJ) drive unit.
 2. It is necessary for using an MR-J4-DU_ _B_(-RJ) drive unit.
 3. It is necessary for using the fully closed loop system.
 4. It is necessary for using an MR-J4-DU_ _A_(-RJ) drive unit in the positioning mode.
 5. It is necessary for using the Modbus RTU communication function.
 6. It is necessary for using a linear servo motor.
 7. It is necessary for using an MR-D30 functional safety unit.

This Instruction Manual does not describe the following items. The following are the same as those for MR-J4- _(-RJ). For the details of the items, refer to each chapter/section indicated in the detailed explanation field. "MR-J4- _B_" means "MR-J4- _B_(-RJ) Servo Amplifier Instruction Manual". "MR-J4- _A_" means "MR-J4- _A_(-RJ) Servo Amplifier Instruction Manual".

Model	Item	Detailed explanation
MR-J4-DU_ _B_(-RJ)	NORMAL GAIN ADJUSTMENT	MR-J4- _B_ chapter 6
	SPECIAL ADJUSTMENT FUNCTIONS (Note)	MR-J4- _B_ chapter 7
	ABSOLUTE POSITION DETECTION SYSTEM	MR-J4- _B_ chapter 12
	USING STO FUNCTION	MR-J4- _B_ chapter 13
	USING A LINEAR SERVO MOTOR	MR-J4- _B_ chapter 14
	FULLY CLOSED LOOP SYSTEM	MR-J4- _B_ chapter 16
	APPLICATION OF FUNCTIONS	MR-J4- _B_ chapter 17
MR-J4-DU_ _A_(-RJ)	NORMAL GAIN ADJUSTMENT	MR-J4- _A_ chapter 6
	SPECIAL ADJUSTMENT FUNCTIONS (Note)	MR-J4- _A_ chapter 7
	ABSOLUTE POSITION DETECTION SYSTEM	MR-J4- _A_ chapter 12
	USING STO FUNCTION	MR-J4- _A_ chapter 13
	COMMUNICATION FUNCTION (MITSUBISHI ELECTRIC GENERAL-PURPOSE AC SERVO PROTOCOL)	MR-J4- _A_ chapter 14
	FULLY CLOSED LOOP SYSTEM	MR-J4- _A_ chapter 17

Note. Refer to chapter 9 in this Instruction Manual for the compatibility with the SEMI-F47 standard.

«Cables used for wiring»

Wires mentioned in this Instruction Manual are selected based on an ambient temperature of 40 °C.

«Contents of the package»

Unpack the converter unit and the drive unit, and check the rating plates to see if the units are as you ordered.

(1) Power regeneration converter unit

Contents	Quantity
Power regeneration converter unit	1
Eyebolt (for 55 kW or more)	2
Magnetic contactor wiring connector	1
MELSERVO-J4 Series Instructions and Cautions for Safe Use of AC Servos	1

(2) Resistance regeneration converter unit

Contents	Quantity
Resistance regeneration converter unit	1
Eyebolt	2
Digital I/O connector	1
MELSERVO-J4 Series Instructions and Cautions for Safe Use of AC Servos	1

(3) Drive unit

Contents	Quantity
Drive unit	1
Bus bar (for 30 kW or more)	2
Eyebolt (for 30 kW or more)	2
MELSERVO-J4 Series Instructions and Cautions for Safe Use of AC Servos	1

CONTENTS

1. FUNCTIONS AND CONFIGURATION	1- 1 to 1-28
1.1 Summary.....	1- 1
1.2 Model designation.....	1- 2
1.2.1 MR-CV_ power regeneration converter unit.....	1- 2
1.2.2 MR-CR_ resistance regeneration converter unit.....	1- 3
1.2.3 Drive unit.....	1- 4
1.3 Combinations of converter units, drive units and servo motors.....	1- 5
1.3.1 Combinations of the power regeneration converter unit and drive unit.....	1- 5
1.3.2 Combinations of the resistance regeneration converter unit and drive unit.....	1-11
1.3.3 Combinations of drive unit and servo motors.....	1-12
1.4 Standard specifications.....	1-13
1.4.1 MR-CV_ power regeneration converter unit.....	1-13
1.4.2 MR-CR_ resistance regeneration converter unit.....	1-15
1.4.3 Drive unit.....	1-16
1.5 Function list.....	1-24
1.6 Configuration including peripheral equipment.....	1-25
1.6.1 MR-CV_ power regeneration converter unit.....	1-25
1.6.2 MR-CR_ resistance regeneration converter unit.....	1-27
2. INSTALLATION	2- 1 to 2- 8
2.1 Installation direction and clearances.....	2- 2
2.1.1 When using MR-CV_ power regeneration converter unit.....	2- 2
2.1.2 When using MR-CR_ resistance regeneration converter unit.....	2- 5
2.2 Keeping out of foreign materials.....	2- 6
2.3 Inspection items.....	2- 6
2.4 Parts having service life.....	2- 7
2.5 Restrictions when using this product at altitude exceeding 1000 m and up to 2000 m above sea level.....	2- 8
3. MR-CV_ POWER REGENERATION CONVERTER UNIT	3- 1 to 3-82
3.1 Function block diagram.....	3- 2
3.2 Structure (parts identification).....	3- 4
3.3 Signals and wiring.....	3- 7
3.3.1 Connection example of power circuit.....	3- 8
3.3.2 Explanation of power supply system.....	3-34
3.3.3 Connectors and pin assignment.....	3-41
3.3.4 Signal (device) explanations.....	3-45
3.3.5 Alarm occurrence timing chart.....	3-46
3.3.6 Forced stop in the power regeneration converter unit.....	3-55
3.3.7 Interfaces.....	3-59
3.3.8 Grounding.....	3-61
3.4 Startup.....	3-62
3.4.1 Switching power on for the first time.....	3-63
3.4.2 Startup.....	3-66
3.4.3 Switch setting and operation section of power regeneration converter unit.....	3-67
3.5 Characteristics.....	3-71

3.5.1	Overload protection characteristics.....	3-71
3.5.2	Power supply capacity and generated loss	3-74
3.5.3	Inrush currents at power-on of the main circuit and control circuit power supplies.....	3-77
3.6	Disabling the protection coordination mode (stand-alone drive).....	3-78
3.6.1	200 V class.....	3-79
3.6.2	400 V class.....	3-81

4. MR-CR_ RESISTANCE REGENERATION CONVERTER UNIT	4- 1 to 4-66
---	---------------------

4.1	Function block diagram.....	4- 2
4.2	Structure	4- 6
4.2.1	Parts identification.....	4- 6
4.2.2	Opening and closing of the terminal block cover	4- 7
4.3	Signals and wiring.....	4-11
4.3.1	Input power supply circuit.....	4-12
4.3.2	Explanation of power supply system.....	4-23
4.3.3	Connectors and pin assignment	4-28
4.3.4	Signal (device) explanations	4-29
4.3.5	Alarm occurrence timing chart	4-30
4.3.6	Forced stop in the resistance regeneration converter unit	4-38
4.3.7	Interfaces.....	4-42
4.3.8	Grounding.....	4-44
4.4	Startup	4-45
4.4.1	Switching power on for the first time	4-46
4.4.2	Startup.....	4-51
4.4.3	Display and operation section of the resistance regeneration converter unit.....	4-52
4.5	Parameters	4-59
4.5.1	Parameter list	4-59
4.5.2	Detailed list of parameters	4-60
4.6	Characteristics	4-62
4.6.1	Overload protection characteristics.....	4-62
4.6.2	Power supply capacity and generated loss	4-63
4.6.3	Inrush currents at power-on of main circuit/control circuit	4-65

5. MR-J4-DU_(-RJ) DRIVE UNIT	5- 1 to 5-44
-------------------------------------	---------------------

5.1	Structure (Parts identification)	5- 1
5.1.1	MR-J4-DU_B_(-RJ).....	5- 2
5.1.2	MR-J4-DU_A_(-RJ).....	5- 9
5.2	Signals and wiring.....	5-14
5.2.1	Signal explanations	5-15
5.2.2	Connectors and pin assignment	5-16
5.3	Parameter	5-18
5.3.1	MR-J4-DU_B_(-RJ).....	5-18
5.3.2	MR-J4-DU_A_(-RJ).....	5-23
5.4	Characteristics	5-24
5.4.1	Drive unit	5-24
5.4.2	Dynamic brake characteristics	5-27
5.4.3	Inrush currents at power-on of control circuit.....	5-34
5.5	Mounting and removing MR-D30.....	5-35
5.5.1	MR-J4-DU900B-RJ to MR-J4-DU22KB-RJ/MR-J4-DU900B4-RJ to MR-J4-DU22KB4-RJ	5-36

6. TROUBLESHOOTING	6- 1 to 6-16
---------------------------	---------------------

6.1 MR-CV_ Power regeneration converter unit.....	6- 1
6.1.1 Explanation for the lists	6- 1
6.1.2 Alarm/warning list.....	6- 1
6.2 MR-CR_ Resistance regeneration converter unit.....	6- 2
6.2.1 Explanation for the lists	6- 2
6.2.2 Alarm/warning list.....	6- 2
6.3 Drive unit.....	6- 3
6.3.1 Explanation for the lists	6- 3
6.3.2 Alarm list.....	6- 4
6.3.3 Warning list.....	6-14

7. DIMENSIONS	7- 1 to 7-12
----------------------	---------------------

7.1 MR-CV_ Power regeneration converter unit.....	7- 1
7.1.1 MR-CV11K(4)/MR-CV18K(4).....	7- 1
7.1.2 MR-CV30K(4)/MR-CV37K(4)/MR-CV45K(4).....	7- 2
7.1.3 MR-CV55K.....	7- 3
7.1.4 MR-CV55K4/MR-CV75K4.....	7- 4
7.2 MR-CR55K(4) Resistance regeneration converter unit.....	7- 5
7.3 Drive unit.....	7- 6
7.3.1 MR-J4-DU_B_(-RJ).....	7- 6
7.3.2 MR-J4-DU_A_(-RJ).....	7-10

8. OPTIONS AND PERIPHERAL EQUIPMENT	8- 1 to 8-70
--	---------------------

8.1 Cable/connector sets	8- 2
8.1.1 Combinations of cable/connector sets	8- 2
8.1.2 Protection coordination cable.....	8- 4
8.2 Regenerative option.....	8- 6
8.2.1 Combination and regenerative power	8- 6
8.2.2 Selection of regenerative option	8- 7
8.2.3 Parameter setting.....	8- 9
8.2.4 Connection of regenerative option	8-10
8.2.5 Dimensions.....	8-12
8.3 External dynamic brake	8-13
8.3.1 Selection of external dynamic brake	8-14
8.3.2 Connection example	8-14
8.3.3 Timing chart.....	8-18
8.3.4 Dimensions.....	8-19
8.4 Selection example of wires	8-22
8.4.1 Connection of converter unit and drive unit	8-22
8.4.2 Connection of power regeneration converter unit and servo amplifier	8-26
8.5 Molded-case circuit breakers, fuses, magnetic contactors	8-28
8.5.1 For main circuit power supply	8-28
8.5.2 For control circuit power supply	8-29
8.6 Power factor improving DC reactor	8-32
8.7 AC reactor.....	8-33

8.8	Noise reduction techniques	8-34
8.8.1	Noise reduction techniques.....	8-34
8.8.2	Noise reduction techniques.....	8-37
8.9	Earth-leakage current breaker.....	8-38
8.9.1	Selection method	8-38
8.9.2	Selection example.....	8-40
8.10	EMC filter (recommended).....	8-41
8.10.1	Combinations with the converter unit.....	8-41
8.10.2	Connection example	8-42
8.10.3	Dimensions	8-43
8.11	FR-BU2-(H) brake unit.....	8-48
8.11.1	Selection.....	8-48
8.11.2	Brake unit parameter setting.....	8-49
8.11.3	Connection example of combination with FR-BR-(H) resistor unit.....	8-49
8.11.4	Combination with MT-BR5-(H) resistor unit.....	8-54
8.11.5	Connection instructions.....	8-62
8.11.6	Wires	8-63
8.11.7	Crimp terminals for L+ and L- terminals of TE2-1 of resistance regeneration converter unit	8-64
8.11.8	Dimensions	8-65
8.12	MR-DCBAR_ bus bar	8-67
8.12.1	Bus bar.....	8-67
8.12.2	Adjustment bar	8-69

9. COMPLIANCE WITH SEMI-F47 STANDARD	9- 1 to 9- 4
---	---------------------

9.1	Parameter setting.....	9- 2
9.2	Requirement of SEMI-F47 standard.....	9- 3
9.3	Calculation of tolerance against instantaneous power failure	9- 3
9.3.1	Delta connection	9- 3
9.3.2	Star connection	9- 3

10. APPENDIX	10- 1 to 10-18
---------------------	-----------------------

10.1	Peripheral equipment manufacturer (for reference).....	10- 1
10.2	Compliance with global standards.....	10- 1
10.2.1	Terms related to safety	10- 1
10.2.2	About safety	10- 1
10.2.3	Installation direction and clearances.....	10- 7
10.2.4	Electrical Installation and configuration diagram	10- 8
10.2.5	Signals.....	10-10
10.2.6	Maintenance and service.....	10-11
10.2.7	Transportation and storage.....	10-12
10.2.8	Technical data.....	10-13
10.2.9	Check list for user documentation.....	10-14
10.3	Special coating-specification product (IEC 60721-3-3 Class 3C2).....	10-15
10.3.1	Summary.....	10-15
10.3.2	Specifications	10-15
10.4	EC declaration of conformity.....	10-16
10.5	Status of general-purpose AC servo products for compliance with the China RoHS directive... ..	10-17
10.5.1	Summary.....	10-17

10.5.2 Status of our products for compliance with the China RoHS directive 10-17
10.5.3 Difference between the China RoHS directive and the EU RoHS directive 10-18
10.5.4 Status of our products for compliance with the China RoHS directive (Chinese) 10-18

1. FUNCTIONS AND CONFIGURATION

1. FUNCTIONS AND CONFIGURATION

1.1 Summary

POINT
<ul style="list-style-type: none"> ● MR-CV_ power regeneration converter unit is used in a combination with MR-J4-DU_B_(-RJ) drive units and MR-J4-_B_(-RJ) servo amplifiers. MR-CV_ cannot be used with MR-J4-DU_A_(-RJ) drive units and MR-J4-_A_(-RJ) servo amplifiers. ● For summary, also refer to section 1.1 of each servo amplifier instruction manual.

In MELSERVO-J4 series, drive units with the CN2L connector are also available as MR-J4-DU_A_-RJ and MR-J4-DU_B_-RJ.

An A/B/Z-phase differential output type external encoder can be connected through the CN2L connector. In a fully closed loop system or a linear servo motor system, a four-wire type external encoder is connectable as well. The following table indicates the communication method and the connector of external encoders compatible with the drive unit.

Operation mode	External encoder communication method	Connector			
		MR-J4-DU_A_	MR-J4-DU_A_-RJ	MR-J4-DU_B_	MR-J4-DU_B_-RJ
Fully closed loop system	Two-wire type	CN2 (Note 1, 2)	CN2L	CN2 (Note 1, 2)	CN2L
	Four-wire type	/		/	
	A/B/Z-phase differential output method				
Scale measurement function	Two-wire type	/	/	CN2 (Note 1, 2)	CN2L
	Four-wire type			/	
	A/B/Z-phase differential output method				
Linear servo motor system	Two-wire type	/	/	CN2 (Note 1)	CN2 (Note 1)
	Four-wire type			/	
	A/B/Z-phase differential output method				CN2L (Note 3)

Note 1. The MR-J4FCCBL03M branch cable is necessary.

2. When the communication method of the servo motor encoder is four-wire type, MR-J4-DU_A_ and MR-J4-DU_B_ cannot be used. Use an MR-J4-DU_A_-RJ or MR-J4-DU_B_-RJ.

3. Connect a thermistor to CN2.

MR-CV_ power regeneration converter unit enables regenerative power generated during deceleration of the servo motor to be returned back to the power supply. MR-CV_ power regeneration converter unit connects with multiple MR-J4-DU_B_(-RJ) drive units and MR-J4-_B_(-RJ) servo amplifiers by sharing the bus voltage, enabling energy-conservation, less wiring, and space-saving. MR-CV_ power regeneration converter unit is compatible with drive units with software version C5 or later.

MR-CR_ resistance regeneration converter unit enables regenerative power generated during deceleration of the servo motor to be consumed by a regenerative resistor.

1. FUNCTIONS AND CONFIGURATION

1.2 Model designation

1.2.1 MR-CV_ power regeneration converter unit

(1) Rating plate

The following shows an example of the rating plate for explanation of each item.

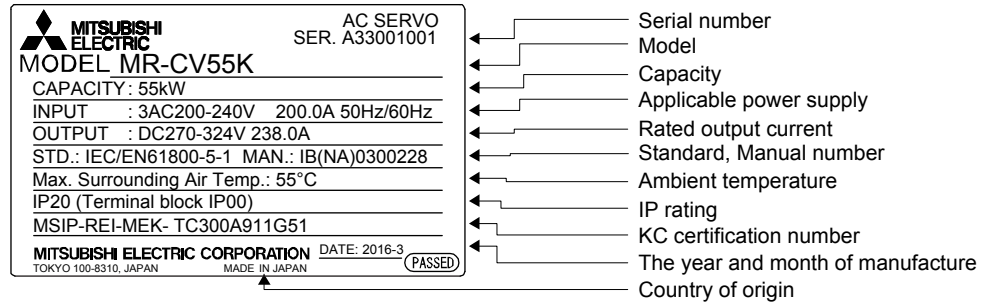

(2) Model

The following describes what each block of a model name indicates. Not all combinations of the symbols are available.

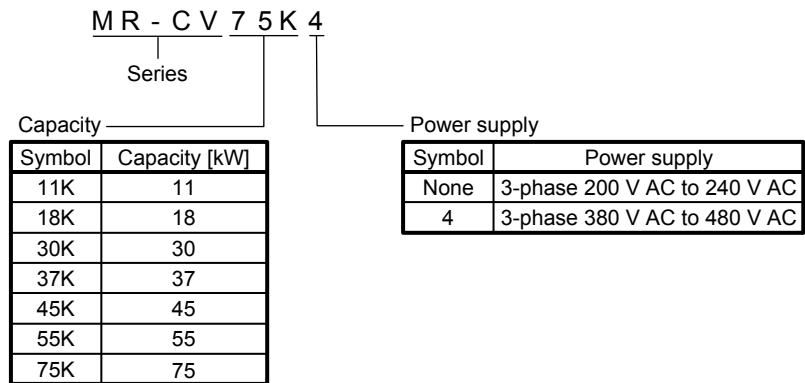

1. FUNCTIONS AND CONFIGURATION

1.2.2 MR-CR_ resistance regeneration converter unit

(1) Rating plate

The following shows an example of the rating plate for explanation of each item.

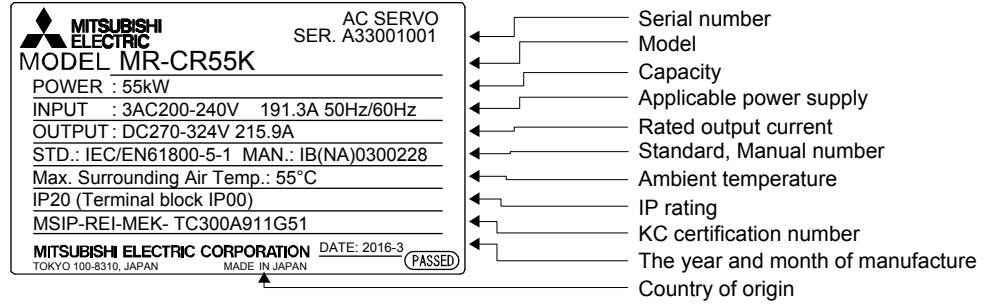

(2) Model

The following describes what each block of a model name indicates. Not all combinations of the symbols are available.

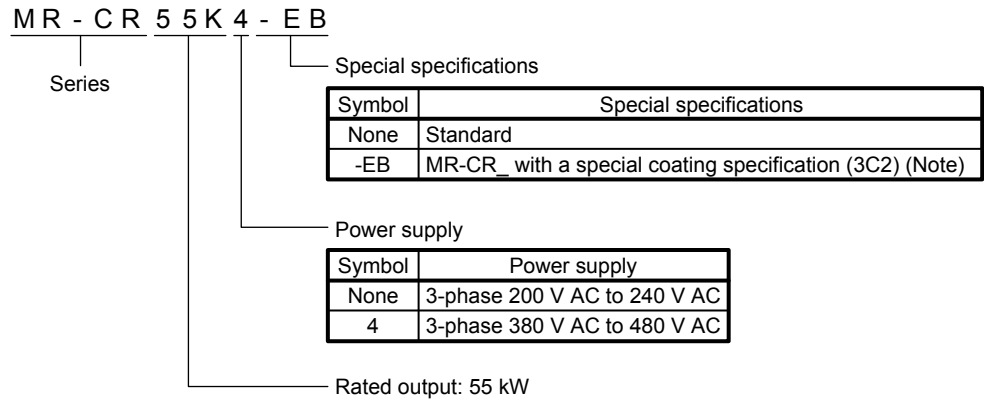

Note. Type with a specially-coated resistance regeneration converter unit board (IEC 60721-3-3 Class 3C2). Refer to section 10.3 for details.

1. FUNCTIONS AND CONFIGURATION

1.2.3 Drive unit

(1) Rating plate

The following shows an example of the rating plate for explanation of each item.

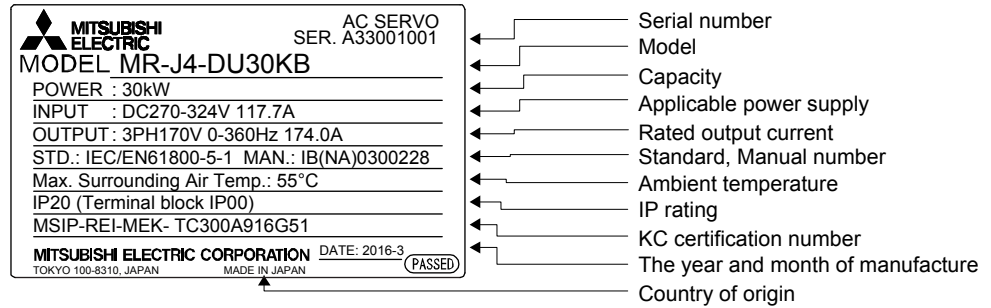

(2) Model

The following describes what each block of a model name indicates. Not all combinations of the symbols are available.

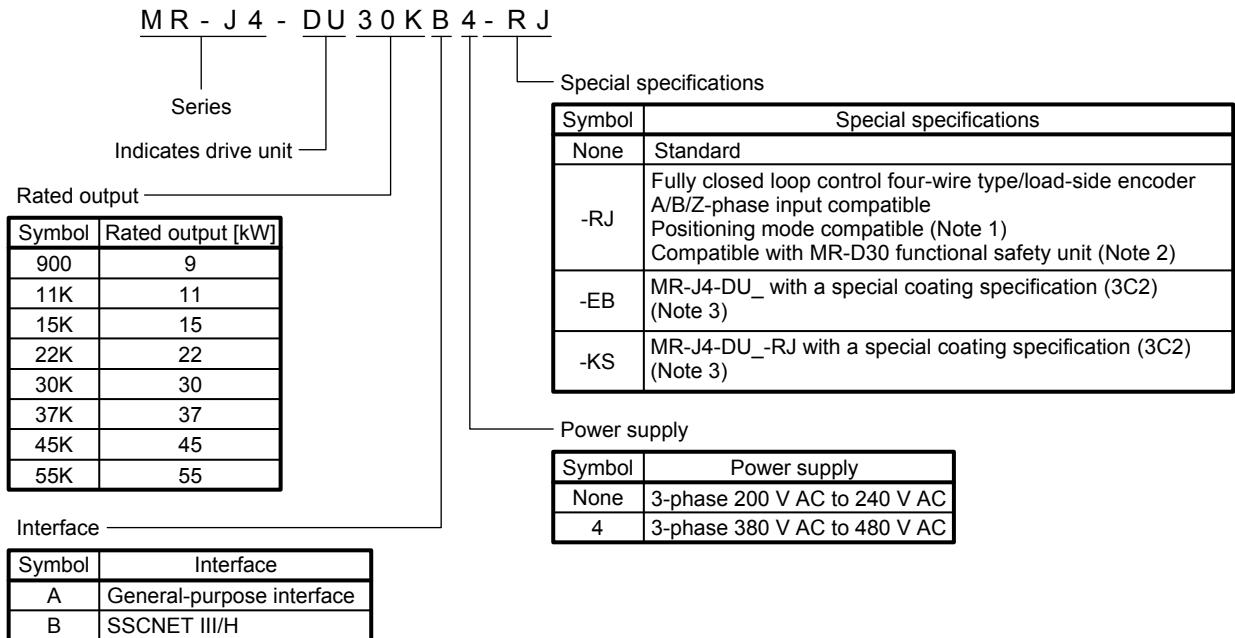

- Note 1. The positioning mode is available only with MR-J4-DU_A_-RJ.
 Note 2. MR-D30 functional safety unit is compatible with drive units with software version B5 or later.
 Note 3. Type with a specially-coated drive unit board (IEC 60721-3-3 Class 3C2). This type is available with the drive unit of 30 kW or more. Refer to section 10.3 for details.

1. FUNCTIONS AND CONFIGURATION

1.3 Combinations of converter units, drive units and servo motors

1.3.1 Combinations of the power regeneration converter unit and drive unit

(1) Connecting one drive unit to one power regeneration converter unit

The drive units are driven at the rated output with the following combinations:

When operating drive units at a load ratio lower than the rated, and having met the selection conditions of (2) in this section, you can select drive units with capacity larger than those of the combinations in the following table.

(a) 200 V class

Power regeneration converter unit	Drive unit
MR-CV18K	MR-J4-DU900B(-RJ) MR-J4-DU11KB(-RJ)
MR-CV30K	MR-J4-DU15KB(-RJ)
MR-CV37K	MR-J4-DU22KB(-RJ)
MR-CV55K	MR-J4-DU30KB(-RJ) MR-J4-DU37KB(-RJ)

(b) 400 V class

Power regeneration converter unit	Drive unit
MR-CV18K4	MR-J4-DU900B4(-RJ) MR-J4-DU11KB4(-RJ)
MR-CV30K4	MR-J4-DU15KB4(-RJ)
MR-CV37K4	MR-J4-DU22KB4(-RJ)
MR-CV55K4	MR-J4-DU30KB4(-RJ) MR-J4-DU37KB4(-RJ) MR-J4-DU45KB4(-RJ) MR-J4-DU55KB4(-RJ)

1. FUNCTIONS AND CONFIGURATION

(2) Connecting multiple drive units to one power regeneration converter unit

(a) Selection method

Select a power regeneration converter unit which meets the following conditions. When all the conditions are fulfilled, multiple drive units can be connected to one power regeneration converter unit. When connecting the multiple drive units, mount the drive units in descending order of capacity, from the right side of the power regeneration converter unit.

- 1) Maximum capacity of MR-J4-DU_ connected to MR-CV_ [kW] ≤ Maximum capacity of MR-J4-DU_ drivable with MR-CV_ [kW]
- 2) Effective value of total output power of servo motors [kW] ≤ Continuous rating of MR-CV_ [kW]
- 3) Maximum value of total output power of servo motors [kW] × 1.2 ≤ Instantaneous maximum rating of MR-CV_ [kW]
- 4) Total widths of MR-J4-DU_ ≤ 800 mm

	MR-CV_ (200 V class)						MR-CV_ (400 V class)						
	11K	18K	30K	37K	45K	55K	11K4	18K4	30K4	37K4	45K4	55K4	75K4
Maximum capacity of MR-J4-DU_ drivable with MR-CV_ [kW]	11	15	30	37	37	37	11	15	30	37	45	55	55
Continuous rating [kW]	7.5	11	20	22	22	37	7.5	11	20	25	25	55	55
Instantaneous maximum rating [kW]	39	60	92	101	125	175	39	60	92	101	125	175	180
Total widths of MR-J4-DU_	800 mm or less												

	MR-J4-DU_- (200 V class)						MR-J4-DU_- (400 V class)							
	900B	11KB	15KB	22KB	30KB	37KB	900B4	11KB4	15KB4	22KB4	30KB4	37KB4	45KB4	55KB4
Unit width [mm]	150	240	300	300	150	240	300	240	300	300	300	300	300	300

1. FUNCTIONS AND CONFIGURATION

(b) Selection example of power regeneration converter unit

Select a power regeneration converter unit for the following drive units:

- Drive unit MR-J4-DU900B/servo motor HG-SR702
- Drive unit MR-J4-DU11KB/servo motor HG-JR11K1M
- Drive unit MR-J4-DU22KB/servo motor HG-JR22K1M

Calculate running power and regenerative power from the servo motor speed and torque as follows:

For rotary servo motor

$$\text{Running power and regenerative power [W]} = \text{Servo motor speed [r/min]} \times \text{Torque [N}\cdot\text{m]} / 9.55$$

For linear servo motor

$$\text{Running power and regenerative power [W]} = \text{Servo motor speed [m/s]} \times \text{Thrust [N]}$$

(Running power with a positive sign, and regenerative power with a negative sign)

Calculate the total output power of the servo motors from the running power and regenerative power of each servo motor.

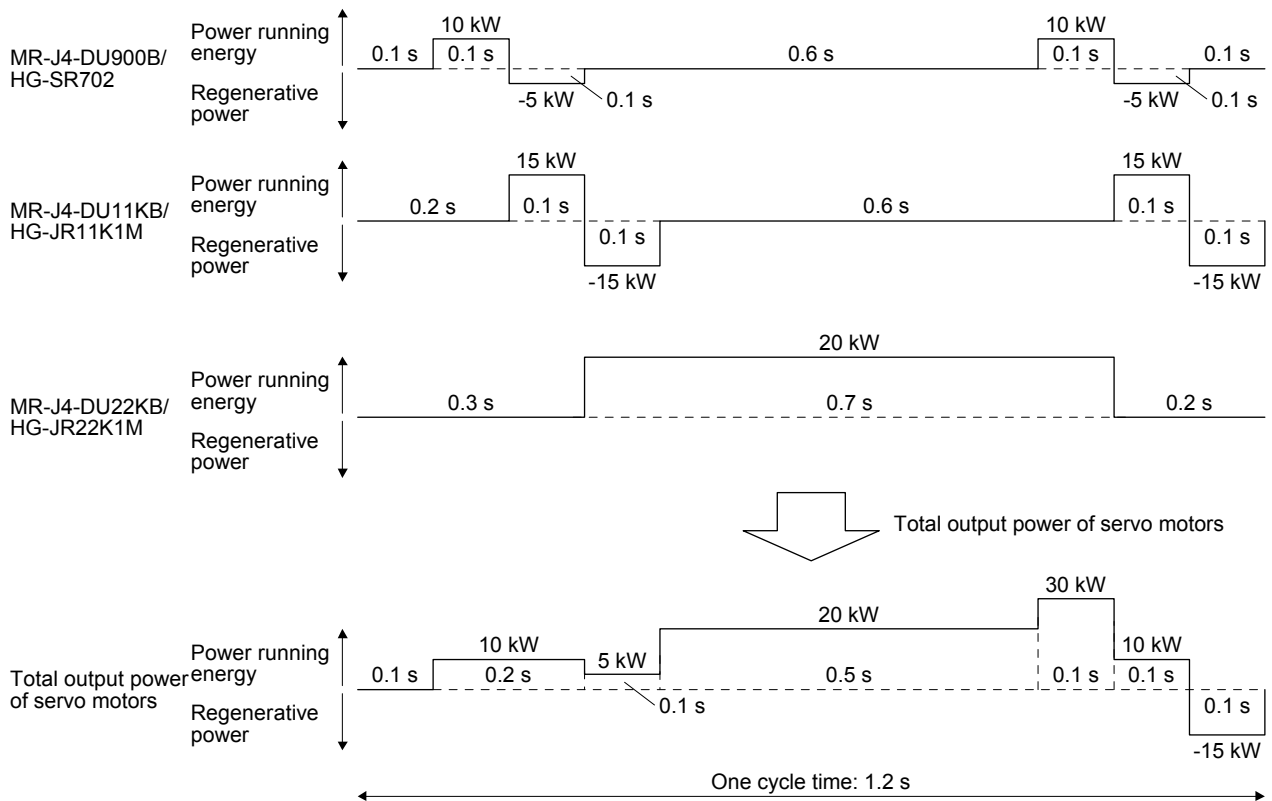

1. FUNCTIONS AND CONFIGURATION

- 1) Maximum capacity of the drive unit [kW] = 22 kW
⇒MR-CV30K or more
- 2) Effective value of total output power of servo motors [kW]
 $= \sqrt{(10^2 \times 0.2 + 5^2 \times 0.1 + 20^2 \times 0.5 + 30^2 \times 0.1 + 10^2 \times 0.1 + (-15)^2 \times 0.1) / 1.2} = 17 \text{ kW}$
⇒MR-CV30K or more
- 3) Maximum value of total output power of servo motors [kW] $\times 1.2 = 30 \text{ kW} \times 1.2 = 36 \text{ kW}$
⇒MR-CV11K or more
- 4) Total widths of drive units
 $= 240 \text{ mm (MR-J4-DU22KB)} + 150 \text{ mm (MR-J4-DU11KB)} + 150 \text{ mm (MR-J4-DU11KB)} = 540 \text{ mm} \leq 800 \text{ mm}$

From the calculation, MR-CV30K is selected for the power regeneration converter unit.

Mount the MR-J4-DU_B_(-RJ) drive units in descending order of capacity, from the right side of the MR-CV_ as follows. Refer to section 2.1 for installation.

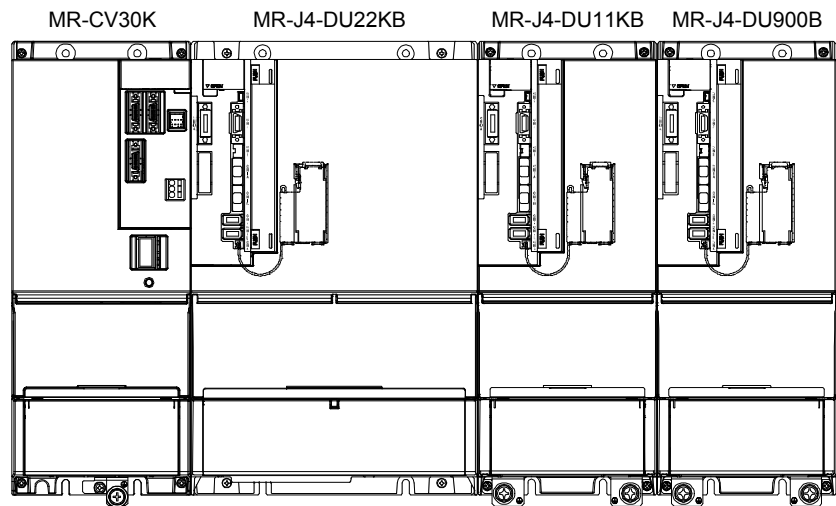

1. FUNCTIONS AND CONFIGURATION

(3) Connecting multiple drive units and servo amplifiers to one power regeneration converter unit

(a) Selection method

Select a power regeneration converter unit which meets the following conditions. When all the conditions are fulfilled, multiple drive units and servo amplifiers can be connected to one power regeneration converter unit. When connecting the multiple drive units, mount the drive units in descending order of capacity, from the right side of the power regeneration converter unit.

- 1) Maximum capacity [kW] of MR-J4-DU_ connected to MR-CV_ ≤ Maximum capacity [kW] of MR-J4-DU_ drivable with MR-CV_
- 2) Total capacity of servo amplifiers [kW] ≤ Total capacity of servo amplifiers drivable with MR-CV_ [kW]
- 3) Number servo amplifiers connected to one MR-CV_ ≤ 6
- 4) Effective value of total output power of servo motors [kW] ≤ Continuous rating of MR-CV_ [kW]
- 5) Maximum value of total output power of servo motors [kW] × 1.2 ≤ Instantaneous maximum rating of MR-CV_ [kW]
- 6) Total widths of MR-J4-DU_ ≤ 800 mm

	MR-CV_ (200 V class)						MR-CV_ (400 V class)						
	11K	18K	30K	37K	45K	55K	11K4	18K4	30K4	37K4	45K4	55K4	75K4
Maximum capacity of MR-J4-DU_ [kW] drivable with MR-CV_	11	15	30	37	37	37	11	15	30	37	45	55	55
Total capacity of drivable servo amplifiers [kW]	7.5	5	15	11	11	27.5	7.5	5	15	11	11	27.5	27.5
Continuous rating [kW]	7.5	11	20	22	22	37	7.5	11	20	25	25	55	55
Instantaneous maximum rating [kW]	39	60	92	101	125	175	39	60	92	101	125	175	180
Maximum number of connectable servo amplifiers	6												
Total widths of MR-J4-DU_	800 mm or less												

	MR-J4-DU_ (200 V class)						MR-J4-DU_ (400 V class)								
	900B	11KB	15KB	22KB	30KB	37KB	900B4	11KB4	15KB4	22KB4	30KB4	37KB4	45KB4	55KB4	
Unit width [mm]	150	240	300	150	240	300	150	240	300	150	240	300	150	240	

(b) Selection example of power regeneration converter unit

Select a power regeneration converter unit for the following drive units and servo amplifiers:

- Servo amplifier MR-J4-500B/servo motor HG-SR502
- Servo amplifier MR-J4-500B/servo motor HG-SR502
- Drive unit MR-J4-DU11KB/servo motor HG-JR11K1M
- Drive unit MR-J4-DU22KB/servo motor HG-JR22K1M

Calculate running power and regenerative power from the servo motor speed and torque as follows:

For rotary servo motor

$$\text{Running power and regenerative power [W]} = \text{Servo motor speed [r/min]} \times \text{Torque [N}\cdot\text{m]} / 9.55$$

For linear servo motor

$$\text{Running power and regenerative power [W]} = \text{Servo motor speed [m/s]} \times \text{Thrust [N]}$$

(Running power with a positive sign, and regenerative power with a negative sign)

1. FUNCTIONS AND CONFIGURATION

Calculate the total output power of the servo motors from the running power and regenerative power of each servo motor.

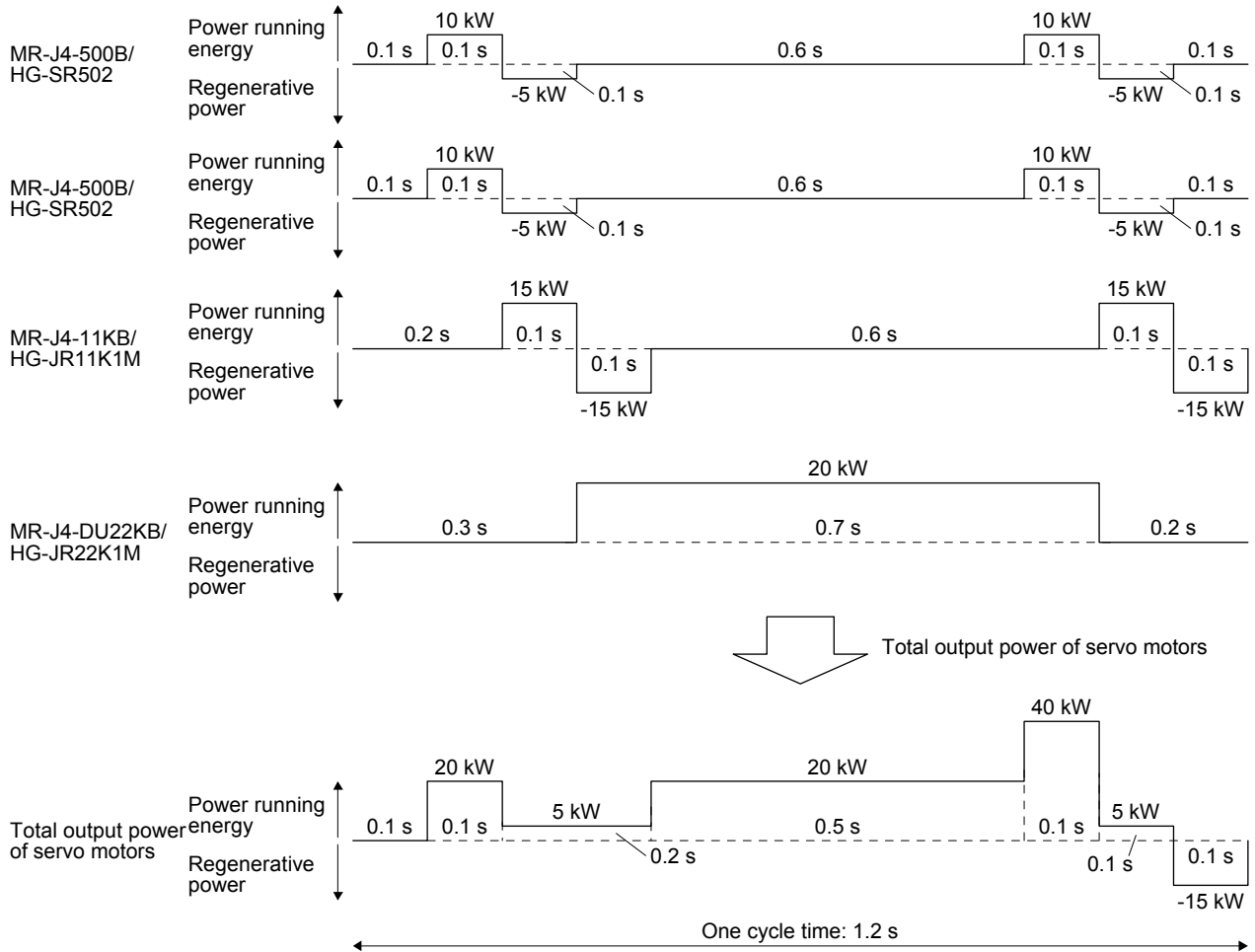

- 1) Maximum capacity of the drive unit [kW] = 22 kW
⇒MR-CV30K or more
- 2) Total of servo amplifier capacities [kW] = 5 kW + 5 kW = 10 kW
⇒MR-CV30K or more
- 3) Effective value of total output power of servo motors [kW]

$$= \sqrt{(20^2 \times 0.1 + 5^2 \times 0.2 + 20^2 \times 0.5 + 40^2 \times 0.1 + 5^2 \times 0.1 + (-15)^2 \times 0.1)/1.2} = 18.93 \text{ kW}$$
 ⇒MR-CV30K or more
- 4) Maximum value of total output power of servo motors [kW] × 1.2 = 40 kW × 1.2 = 48 kW
⇒MR-CV18K or more
- 5) Number of servo amplifiers: $2 \leq 6$
- 6) Total width of drive units = 240 mm (MR-J4-DU22KB) + 150 mm (MR-J4-DU11KB) = 390 mm ≤ 800 mm

1. FUNCTIONS AND CONFIGURATION

From the calculation, MR-CV30K is selected for the power regeneration converter unit.
Mount the MR-J4-DU_B_(-RJ) drive units in descending order of capacity, from the right side of the MR-CV_ as follows. Refer to section 2.1 for installation.

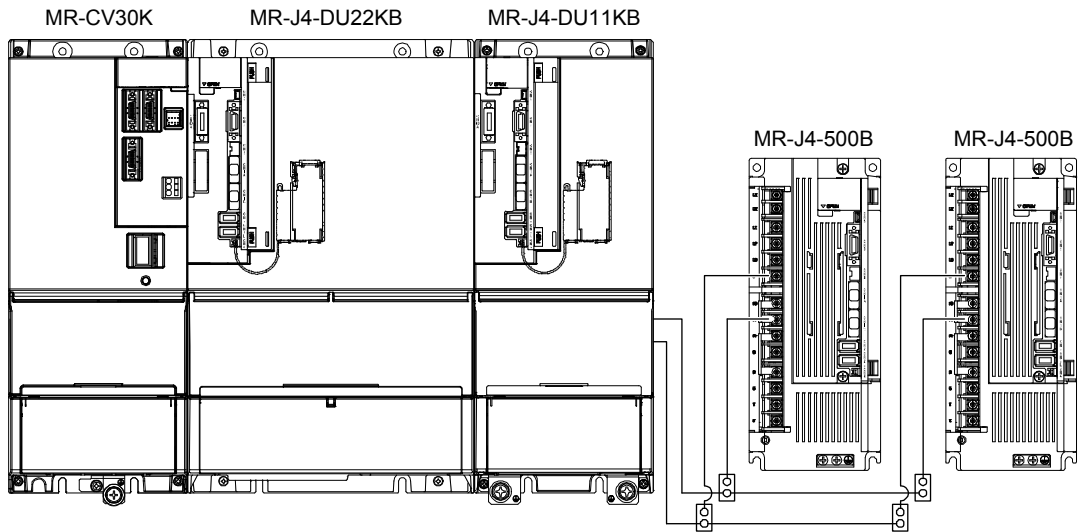

1.3.2 Combinations of the resistance regeneration converter unit and drive unit

(1) 200 V class

Resistance regeneration converter unit	Drive unit
MR-CR55K	MR-J4-DU30KB(-RJ) MR-J4-DU30KA(-RJ) MR-J4-DU37KB(-RJ) MR-J4-DU37KA(-RJ)

(2) 400 V class

Resistance regeneration converter unit	Drive unit
MR-CR55K4	MR-J4-DU30KB4(-RJ) MR-J4-DU30KA4(-RJ) MR-J4-DU37KB4(-RJ) MR-J4-DU37KA4(-RJ) MR-J4-DU45KB4(-RJ) MR-J4-DU45KA4(-RJ) MR-J4-DU55KB4(-RJ) MR-J4-DU55KA4(-RJ)

1. FUNCTIONS AND CONFIGURATION

1.3.3 Combinations of drive unit and servo motors

(1) 200 V class

Drive unit	Rotary servo motor		Linear servo motor (primary side)
	HG-SR	HG-JR	
MR-J4-DU900B(-RJ)	702 (Note 2)	601 801 701M (Note 2) 503 (Note 1) 703 (Note 2) 903	LM-FP2F-18M-1SS0 LM-FP4D-24M-1SS0
MR-J4-DU11KB(-RJ)			12K1 11K1M
MR-J4-DU15KB(-RJ)		15K1 15K1M	LM-FP4H-48M-1SS0
MR-J4-DU22KB(-RJ)		20K1 25K1 22K1M	
MR-J4-DU30KB(-RJ)		30K1	
MR-J4-DU30KA(-RJ)		30K1M	
MR-J4-DU37KB(-RJ)		37K1	
MR-J4-DU37KA(-RJ)		37K1M	

- Note 1. The maximum torque can be increased to 400% of the rated torque.
 2. By enabling the maximally increased torque function when drive unit is connected with [Pr. PC23], the maximum torque can be increased. (Refer to section 5.3.1.)

(2) 400 V class

Drive unit	Rotary servo motor		Linear servo motor (primary side)
	HG-SR	HG-JR	
MR-J4-DU900B4(-RJ)	7024 (Note 2)	6014 8014 701M4 (Note 2) 5034 (Note 1) 7034 (Note 2) 9034	
MR-J4-DU11KB4(-RJ)			12K14 11K1M4
MR-J4-DU15KB4(-RJ)		15K14 15K1M4	
MR-J4-DU22KB4(-RJ)		20K14 22K1M4 25K14	LM-FP5H-60M-1SS0
MR-J4-DU30KB4(-RJ)		30K14	
MR-J4-DU30KA4(-RJ)		30K1M4	
MR-J4-DU37KB4(-RJ)		37K14	
MR-J4-DU37KA4(-RJ)		37K1M4	
MR-J4-DU45KB4(-RJ)		45K1M4	
MR-J4-DU45KA4(-RJ)			
MR-J4-DU55KB4(-RJ)		55K1M4	
MR-J4-DU55KA4(-RJ)			

- Note 1. The maximum torque can be increased to 400% of the rated torque.
 2. By enabling the maximally increased torque function when drive unit is connected with [Pr. PC23], the maximum torque can be increased. (Refer to section 5.3.1.)

1. FUNCTIONS AND CONFIGURATION

1.4 Standard specifications

1.4.1 MR-CV_ power regeneration converter unit

(1) 200 V class

Model: MR-CV_		11K	18K	30K	37K	45K	55K
Output	Rated voltage	270 V DC to 324 V DC					
	Rated current [A]	41	76	144	164	198	238
Main circuit power supply input	Voltage/Frequency	3-phase 200 V AC to 240 V AC, 50 Hz/60 Hz					
	Rated current [A]	35	65	107	121	148	200
	Permissible voltage fluctuation	3-phase 170 V AC to 264 V AC					
	Permissible frequency fluctuation	Within $\pm 3\%$					
	Power supply capacity [kVA]	Refer to section 3.5.2.					
	Inrush current [A]	Refer to section 3.5.3.					
Control circuit power supply input	Voltage/Frequency	1-phase 200 V AC to 240 V AC, 50 Hz/60 Hz					
	Rated current [A]	0.2					
	Permissible voltage fluctuation	1-phase 170 V AC to 264 V AC					
	Permissible frequency fluctuation	Within $\pm 3\%$					
	Power consumption [W]	30					
	Inrush current [A]	Refer to section 3.5.3.					
Interface power supply	Voltage	24 V DC $\pm 10\%$					
	Current capacity [A]	0.35 (Note 1)					
Capacity [kW]		11	18	30	37	45	55
Protective functions	Undervoltage protection, regenerative error protection, regenerative overvoltage shut-off, MC drive circuit error, open-phase detection, inrush current suppression circuit error, main circuit device overheat, cooling fan error, and overload shut-off (electronic thermal)						
Main circuit type	Converter with power regeneration function						
Continuous rating [kW]		7.5	11	20	22	22	37
Instantaneous maximum rating [kW]		39	60	92	101	125	175
Compliance with global standards	CE marking	LVD: EN 61800-5-1 EMC: EN 61800-3 MD: EN ISO 13849-1, EN 61800-5-2, EN 62061					
	UL standard	UL 508C					
Structure (IP rating)	Force cooling, open (IP20) (Note 2)						
Environment	Ambient temperature	Operation	0 °C to 55 °C (non-freezing)				
		Storage	-20 °C to 65 °C (non-freezing)				
	Ambient humidity	Operation	5 %RH to 90 %RH (non-condensing)				
		Storage					
	Ambience	Indoors (no direct sunlight), free from corrosive gas, flammable gas, oil mist, dust, and dirt					
	Altitude	2000 m or less above sea level (Note 3)					
Vibration resistance	5.9 m/s ² , at 10 Hz to 55 Hz (X, Y, Z axes)						
Mass [kg]		6.1		12.1		25.0	

Note 1. 0.35 A is the value applicable when all I/O signals are used. The current capacity can be decreased by reducing the number of I/O points.

2. Except for the terminal block.

3. Follow the restrictions in section 2.5 when using this product at altitude exceeding 1000 m and up to 2000 m above sea level.

1. FUNCTIONS AND CONFIGURATION

(2) 400 V class

Model: MR-CV_		11K4	18K4	30K4	37K4	45K4	55K4	75K4	
Output	Rated voltage	513 V DC to 648 V DC							
	Rated current [A]	21	38	72	82	99	119	150	
Main circuit power supply input	Voltage/Frequency	3-phase 380 V AC to 480 V AC, 50 Hz/60 Hz							
	Rated current [A]	18	35	61	70	85	106	130	
	Permissible voltage fluctuation	3-phase 323 V AC to 528 V AC							
	Permissible frequency fluctuation	Within $\pm 3\%$							
	Power supply capacity [kVA]	Refer to section 3.5.2.							
	Inrush current [A]	Refer to section 3.5.3.							
Control circuit power supply input	Voltage/Frequency	1-phase 380 V AC to 480 V AC, 50 Hz/60 Hz							
	Rated current [A]	0.1							
	Permissible voltage fluctuation	1-phase 323 V AC to 528 V AC							
	Permissible frequency fluctuation	Within $\pm 3\%$							
	Power consumption [W]	30							
	Inrush current [A]	Refer to section 3.5.3.							
Interface power supply	Voltage	24 V DC $\pm 10\%$							
	Current capacity [A]	0.35 (Note 1)							
Capacity [kW]		11	18	30	37	45	55	75	
Protective functions	Undervoltage protection, regenerative error protection, regenerative overvoltage shut-off, MC drive circuit error, open-phase detection, inrush current suppression circuit error, main circuit device overheat, cooling fan error, and overload shut-off (electronic thermal)								
Main circuit type	Converter with power regeneration function								
Continuous rating [kW]		7.5	11	20	25	25	55	55	
Instantaneous maximum rating [kW]		39	60	92	101	125	175	180	
Compliance with global standards	CE marking	LVD: EN 61800-5-1 EMC: EN 61800-3 MD: EN ISO 13849-1, EN 61800-5-2, EN 62061							
	UL standard	UL 508C							
Structure (IP rating)	Force cooling, open (IP20) (Note 2)								
Environment	Ambient temperature	Operation	0 °C to 55 °C (non-freezing)						
		Storage	-20 °C to 65 °C (non-freezing)						
	Ambient humidity	Operation	5 %RH to 90 %RH (non-condensing)						
		Storage							
	Ambience	Indoors (no direct sunlight), free from corrosive gas, flammable gas, oil mist, dust, and dirt							
	Altitude	2000 m or less above sea level (Note 3)							
Vibration resistance	5.9 m/s ² , at 10 Hz to 55 Hz (X, Y, Z axes)								
Mass [kg]		6.1		12.1			25.0		

Note 1. 0.35 A is the value applicable when all I/O signals are used. The current capacity can be decreased by reducing the number of I/O points.

2. Except for the terminal block.

3. Follow the restrictions in section 2.5 when using this product at altitude exceeding 1000 m and up to 2000 m above sea level.

1. FUNCTIONS AND CONFIGURATION

1.4.2 MR-CR_ resistance regeneration converter unit

Model: MR-CR_		55 K	55K4	
Output	Rated voltage	270 V DC to 324 V DC		
	Rated current [A]	215.9	113.8	
Main circuit power supply input	Voltage/Frequency	3-phase 200 V AC to 240 V AC, 50 Hz/60 Hz	3-phase 380 V AC to 480 V AC, 50 Hz/60 Hz	
	Rated current [A]	191.3	100.7	
	Permissible voltage fluctuation	3-phase 170 V AC to 264 V AC	3-phase 323 V AC to 528 V AC	
	Permissible frequency fluctuation	Within $\pm 5\%$		
	Power supply capacity [kVA]	Refer to section 4.6.2.		
	Inrush current [A]	Refer to section 4.6.3.		
Control circuit power supply input	Voltage/Frequency	1-phase 200 V AC to 240 V AC, 50 Hz/60 Hz	1-phase 380 V AC to 480 V AC, 50 Hz/60 Hz	
	Rated current [A]	0.3	0.2	
	Permissible voltage fluctuation	1-phase 170 V AC to 264 V AC	1-phase 323 V AC to 528 V AC	
	Permissible frequency fluctuation	Within $\pm 5\%$		
	Power consumption [W]	45		
	Inrush current [A]	Refer to section 4.6.3.		
Interface power supply	Voltage	24 V DC $\pm 10\%$		
	Current capacity [A]	0.15 (Note 1)		
Rated output [kW]	55			
Regenerative power (regenerative option)	One MR-RB139: 1300 W Three MR-RB137: 3900 W	One MR-RB137-4: 1300 W Three MR-RB13V-4: 3900 W		
Protective functions	Regenerative overvoltage shut-off, overload shut-off (electronic thermal), regenerative error protection, undervoltage protection, and instantaneous power failure protection			
Compliance with global standards	CE marking	LVD: EN 61800-5-1 EMC: EN 61800-3		
	UL standard	UL 508C		
Structure (IP rating)	Force cooling, open (IP20) (Note 2)			
Environment	Ambient temperature	Operation	0 °C to 55 °C (non-freezing)	
		Storage	-20 °C to 65 °C (non-freezing)	
	Ambient humidity	Operation	5 %RH to 90 %RH (non-condensing)	
		Storage		
	Ambience	Indoors (no direct sunlight), free from corrosive gas, flammable gas, oil mist, dust, and dirt		
	Altitude	2000 m or less above sea level (Note 3)		
Vibration resistance	5.9 m/s ² , at 10 Hz to 55 Hz (X, Y, Z axes)			
Mass [kg]	22			

Note 1. 0.15 A is the value applicable when all I/O signals are used. The current capacity can be decreased by reducing the number of I/O points.

2. Except for the terminal block.

3. Follow the restrictions in section 2.5 when using this product at altitude exceeding 1000 m and up to 2000 m above sea level.

1. FUNCTIONS AND CONFIGURATION

1.4.3 Drive unit

(1) MR-J4-DU_B_(-RJ)

(a) 200 V class

Model MR-J4-DU_(-RJ)		900B	11KB	15KB	22KB	30KB	37KB
Output	Rated voltage	3-phase 170 V AC					
	Rated current [A]	54	68	87	126	174	204
Main circuit power supply input		The main circuit power of the drive unit is supplied by the converter unit.					
Control circuit power supply input	Voltage/Frequency	1-phase 200 V AC to 240 V AC, 50 Hz/60 Hz					
	Rated current [A]	0.3					
	Permissible voltage fluctuation	1-phase 170 V AC to 264 V AC					
	Permissible frequency fluctuation	Within $\pm 5\%$					
	Power consumption [W]	45					
	Inrush current [A]	Refer to section 5.4.3.					
Interface power supply	Voltage	24 V DC $\pm 10\%$					
	Current capacity [A]	0.3 (including CN8 connector signals) (Note 1)					
Control method		Sine-wave PWM control, current control method					
Dynamic brake		External option (Note 6, 7)					
SSCNET III/H communication cycle (Note 5)		0.222 ms, 0.444 ms, 0.888 ms					
Fully closed loop control		Compatible					
Scale measurement function		Compatible					
Load-side encoder interface (Note 4)		Mitsubishi Electric high-speed serial communication					
Communication function		USB: connection to a personal computer or others (MR Configurator2-compatible)					
Encoder output pulses		Compatible (A/B/Z-phase pulse)					
Analog monitor		Two channels					
Protective functions		Overcurrent shut-off, overload shut-off (electronic thermal), servo motor overheat protection, encoder error protection, undervoltage protection, instantaneous power failure protection, overspeed protection, error excessive protection, magnetic pole detection protection, and linear servo control fault protection					
Functional safety		STO (IEC/EN 61800-5-2)					
Safety performance	Standards certified by CB (Note 8)	EN ISO 13849-1 category 3 PL e, IEC 61508 SIL 3, EN 62061 SIL CL3, EN 61800-5-2					
	Response performance	8 ms or less (STO input off \rightarrow energy shut off)					
	Test pulse input (STO) (Note 2)	Test pulse interval: 1 Hz to 25 Hz Test pulse off time: Up to 1 ms					
	Mean time to dangerous failure (MTTFd)	MTTFd ≥ 100 [years] (314a)					
	Diagnostic coverage (DC)	DC = Medium, 97.6 [%]					
	Probability of dangerous Failure per Hour (PFH)	6.4×10^{-9} [1/h]					
Compliance with global standards	CE marking	LVD: EN 61800-5-1 EMC: EN 61800-3 MD: EN ISO 13849-1, EN 61800-5-2, EN 62061					
	UL standard	UL 508C					
Structure (IP rating)		Force cooling, open (IP20) (Note 3)					
Environment	Ambient temperature	Operation	0 °C to 55 °C (non-freezing)				
		Storage	-20 °C to 65 °C (non-freezing)				
	Ambient humidity	Operation	5 %RH to 90 %RH (non-condensing)				
		Storage					
	Ambience	Indoors (no direct sunlight), free from corrosive gas, flammable gas, oil mist, dust, and dirt					
	Altitude	2000 m or less above sea level (Note 9)					
Vibration resistance	5.9 m/s ² , at 10 Hz to 55 Hz (X, Y, Z axes)						
Mass [kg]		9.9	15.2		21		

1. FUNCTIONS AND CONFIGURATION

- Note
1. 0.3 A is the value applicable when all I/O signals are used. The current capacity can be decreased by reducing the number of I/O points.
 2. Test pulse is a signal which instantaneously turns off a signal to the drive unit at a constant period for external circuit to self-diagnose.
 3. Except for the terminal block.
 4. The MR-J4-DU_B drive unit is compatible only with the two-wire type. The MR-J4-DU_B-RJ drive unit is compatible with the two-wire type, four-wire type, and A/B/Z-phase differential output method. Refer to section 1.1 for details.
 5. The communication cycle depends on the controller specifications and the number of axes connected.
 6. Use an external dynamic brake for this drive unit. Failure to do so will cause an accident because the servo motor does not stop immediately but coasts at emergency stop. Ensure the safety in the entire equipment. For wiring of the external dynamic brake, refer to section 8.3.
 7. The external dynamic brake cannot be used for compliance with SEMI-F47 standard. Do not assign DB (Dynamic brake interlock) with [Pr. PD07] to [Pr. PD09]. Doing so will cause the drive unit to become servo-off when an instantaneous power failure occurs.
 8. The safety level depends on the setting value of [Pr. PF18 STO diagnosis error detection time] and whether STO input diagnosis by TOFB output is performed or not. For details, refer to the Function column of [Pr. PF18] in section 5.2.6 of "MR-J4-_B_(-RJ) Servo Amplifier Instruction Manual".
 9. Follow the restrictions in section 2.5 when using this product at altitude exceeding 1000 m and up to 2000 m above sea level.

1. FUNCTIONS AND CONFIGURATION

(b) 400 V class

Model MR-J4-DU_(-RJ)		900B4	11KB4	15KB4	22KB4	30KB4	37KB4	45KB4	55KB4
Output	Rated voltage	3-phase 323 V AC							
	Rated current [A]	25	32	41	63	87	102	131	143
Main circuit power supply input		The main circuit power of the drive unit is supplied by the converter unit.							
Control circuit power supply input	Voltage/Frequency	1-phase 380 V AC to 480 V AC, 50 Hz/60 Hz							
	Rated current [A]	0.2							
	Permissible voltage fluctuation	1-phase 323 V AC to 528 V AC							
	Permissible frequency fluctuation	Within $\pm 5\%$							
	Power consumption [W]	45							
	Inrush current [A]	Refer to section 5.4.3.							
Interface power supply	Voltage	24 V DC $\pm 10\%$							
	Current capacity [A]	0.3 (including CN8 connector signals) (Note 1)							
Control method		Sine-wave PWM control, current control method							
Dynamic brake		External option (Note 6, 7)							
SSCNET III/H communication cycle (Note 5)		0.222 ms, 0.444 ms, 0.888 ms							
Fully closed loop control		Compatible							
Scale measurement function		Compatible							
Load-side encoder interface (Note 4)		Mitsubishi Electric high-speed serial communication							
Communication function		USB: connection to a personal computer or others (MR Configurator2-compatible)							
Encoder output pulses		Compatible (A/B/Z-phase pulse)							
Analog monitor		Two channels							
Protective functions		Overcurrent shut-off, overload shut-off (electronic thermal), servo motor overheat protection, encoder error protection, undervoltage protection, instantaneous power failure protection, overspeed protection, error excessive protection, magnetic pole detection protection, and linear servo control fault protection							
Functional safety		STO (IEC/EN 61800-5-2)							
Safety performance	Standards certified by CB (Note 8)	EN ISO 13849-1 category 3 PL e, IEC 61508 SIL 3, EN 62061 SIL CL3, EN 61800-5-2							
	Response performance	8 ms or less (STO input off \rightarrow energy shut off)							
	Test pulse input (STO) (Note 2)	Test pulse interval: 1 Hz to 25 Hz Test pulse off time: Up to 1 ms							
	Mean time to dangerous failure (MTTFd)	MTTFd ≥ 100 [years] (314a)							
	Diagnostic coverage (DC)	DC = Medium, 97.6 [%]							
	Probability of dangerous Failure per Hour (PFH)	6.4×10^{-9} [1/h]							
Compliance with global standards	CE marking	LVD: EN 61800-5-1 EMC: EN 61800-3 MD: EN ISO 13849-1, EN 61800-5-2, EN 62061							
	UL standard	UL 508C							
Structure (IP rating)		Force cooling, open (IP20) (Note 3)							
Environment	Ambient temperature	Operation	0 °C to 55 °C (non-freezing)						
		Storage	-20 °C to 65 °C (non-freezing)						
	Ambient humidity	Operation	5 %RH to 90 %RH (non-condensing)						
		Storage	5 %RH to 90 %RH (non-condensing)						
	Ambience	Indoors (no direct sunlight), free from corrosive gas, flammable gas, oil mist, dust, and dirt							
	Altitude	2000 m or less above sea level (Note 9)							
Vibration resistance	5.9 m/s ² , at 10 Hz to 55 Hz (X, Y, Z axes)								
Mass [kg]		9.9	15.2	16	21				

1. FUNCTIONS AND CONFIGURATION

- Note
1. 0.3 A is the value applicable when all I/O signals are used. The current capacity can be decreased by reducing the number of I/O points.
 2. Test pulse is a signal which instantaneously turns off a signal to the drive unit at a constant period for external circuit to self-diagnose.
 3. Except for the terminal block.
 4. The MR-J4-DU_B drive unit is compatible only with the two-wire type. The MR-J4-DU_B-RJ drive unit is compatible with the two-wire type, four-wire type, and A/B/Z-phase differential output method. Refer to section 1.1 for details.
 5. The communication cycle depends on the controller specifications and the number of axes connected.
 6. Use an external dynamic brake for this drive unit. Failure to do so will cause an accident because the servo motor does not stop immediately but coasts at emergency stop. Ensure the safety in the entire equipment. For wiring of the external dynamic brake, refer to section 8.3.
 7. The external dynamic brake cannot be used for compliance with SEMI-F47 standard. Do not assign DB (Dynamic brake interlock) with [Pr. PD07] to [Pr. PD09]. Doing so will cause the drive unit to become servo-off when an instantaneous power failure occurs.
 8. The safety level depends on the setting value of [Pr. PF18 STO diagnosis error detection time] and whether STO input diagnosis by TOFB output is performed or not. For details, refer to the Function column of [Pr. PF18] in section 5.2.6 of "MR-J4-_B_(-RJ) Servo Amplifier Instruction Manual".
 9. Follow the restrictions in section 2.5 when using this product at altitude exceeding 1000 m and up to 2000 m above sea level.

1. FUNCTIONS AND CONFIGURATION

(2) MR-J4-DU_A_(-RJ)

(a) 200 V class

Model MR-J4-DU_(-RJ)		30KA	37KA
Output	Rated voltage	3-phase 170 V AC	
	Rated current [A]	174	204
Main circuit power supply input		The main circuit power of the drive unit is supplied by the converter unit.	
Control circuit power supply input	Voltage/Frequency	1-phase 200 V AC to 240 V AC, 50 Hz/60 Hz	
	Rated current [A]	0.3	
	Permissible voltage fluctuation	1-phase 170 V AC to 264 V AC	
	Permissible frequency fluctuation	Within $\pm 5\%$	
	Power consumption [W]	45	
	Inrush current [A]	Refer to section 5.4.3.	
Interface power supply	Voltage	24 V DC $\pm 10\%$	
	Current capacity [A]	0.5 (including CN8 connector signals) (Note 1)	
Control method		Sine-wave PWM control, current control method	
Dynamic brake		External option (Note 5, 7)	
Fully closed loop control		Compatible	
Load-side encoder interface (Note 6)		Mitsubishi Electric high-speed serial communication	
Communication function		USB: connection to a personal computer or others (MR Configurator2-compatible)	
		RS-422/RS-485: 1 : n communication (up to 32 axes)	
Encoder output pulses		Compatible (A/B/Z-phase pulse)	
Analog monitor		Two channels	
Position control mode	Max. input pulse frequency	4 Mpulses/s (for differential receiver) (Note 4), 200 kpulses/s (for open collector)	
	Positioning feedback pulse	Encoder resolution (resolution per servo motor revolution): 22 bits	
	Command pulse multiplying factor	Electronic gear A/B multiple, A:1 to 16777215, B:1 to 16777215, $1/10 < A/B < 4000$	
	In-position range setting	0 pulse to ± 65535 pulses (command pulse unit)	
	Error excessive	± 3 revolutions	
	Torque limit	Set with parameter or external analog input (0 V DC to +10 V DC/maximum torque)	
Speed control mode	Speed control range	Analog speed command 1: 2000, internal speed command 1: 5000	
	Analog speed command input	0 to ± 10 V DC/rated speed (The speed at 10 V is changeable with [Pr. PC12].)	
	Speed fluctuation ratio	$\pm 0.01\%$ or less (load fluctuation 0% to 100%), 0% (power fluctuation $\pm 10\%$), $\pm 0.2\%$ or less (ambient temperature $25\text{ }^{\circ}\text{C} \pm 10\text{ }^{\circ}\text{C}$) when using analog speed command	
	Torque limit	Set with parameter or external analog input (0 V DC to +10 V DC/maximum torque)	
Torque control mode	Analog torque command input	0 V DC to ± 8 V DC/maximum torque (input impedance 10 k Ω to 12 k Ω)	
	Speed limit	Set by parameter setting or external analog input (0 V DC to 10 V DC/rated speed)	
Positioning mode		Refer to section 1.1 of "MR-J4-_A_-RJ Servo Amplifier Instruction Manual (Positioning Mode)" The positioning mode is available with MR-J4-DU_A_-RJ drive units with software version B3 or later.	
Protective functions		Overcurrent shut-off, overload shut-off (electronic thermal), servo motor overheat protection, encoder error protection, undervoltage protection, instantaneous power failure protection, overspeed protection, and error excessive protection	
Functional safety		STO (IEC/EN 61800-5-2)	

1. FUNCTIONS AND CONFIGURATION

Model MR-J4-DU_(-RJ)		30KA	37KA
Safety performance	Standards certified by CB (Note 9)	EN ISO 13849-1 category 3 PL e, IEC 61508 SIL 3, EN 62061 SIL CL3, EN 61800-5-2	
	Response performance	8 ms or less (STO input off → energy shut off)	
	Test pulse input (STO) (Note 3)	Test pulse interval: 1 Hz to 25 Hz Test pulse off time: Up to 1 ms	
	Mean time to dangerous failure (MTTFd)	MTTFd ≥ 100 [years] (314a)	
	Diagnostic coverage (DC)	DC = Medium, 97.6 [%]	
	Probability of dangerous Failure per Hour (PFH)	6.4 × 10 ⁻⁹ [1/h]	
Compliance with global standards	CE marking	LVD: EN 61800-5-1 EMC: EN 61800-3 MD: EN ISO 13849-1, EN 61800-5-2, EN 62061	
	UL standard	UL 508C	
Structure (IP rating)		Force cooling, open (IP20) (Note 3)	
Environment	Ambient temperature	Operation	0 °C to 55 °C (non-freezing)
		Storage	-20 °C to 65 °C (non-freezing)
	Ambient humidity	Operation	5 %RH to 90 %RH (non-condensing)
		Storage	
	Ambience	Indoors (no direct sunlight), free from corrosive gas, flammable gas, oil mist, dust, and dirt	
	Altitude	2000 m or less above sea level (Note 10)	
Vibration resistance	5.9 m/s ² , at 10 Hz to 55 Hz (X, Y, Z axes)		
Mass	[kg]	21	

- Note
- 0.5 A is the value applicable when all I/O signals are used. The current capacity can be decreased by reducing the number of I/O points.
 - Test pulse is a signal which instantaneously turns off a signal to the drive unit at a constant period for external circuit to self-diagnose.
 - Except for the terminal block.
 - 1 Mpulse/s or lower commands are supported in the initial setting. When inputting commands between over 1 Mpulse/s and 4 Mpulses/s, change the setting in [Pr. PA13].
 - Use an external dynamic brake for this drive unit. Failure to do so will cause an accident because the servo motor does not stop immediately but coasts at emergency stop. Ensure the safety in the entire equipment. For wiring of the external dynamic brake, refer to section 8.3.
 - The MR-J4-DU_A drive unit is compatible only with the two-wire type. The MR-J4-DU_A-RJ drive unit is compatible with the two-wire type, four-wire type, and A/B/Z-phase differential output method. Refer to section 1.1 for details.
 - The external dynamic brake cannot be used for compliance with SEMI-F47 standard. Do not assign DB (Dynamic brake interlock) with [Pr. PD23] to [Pr. PD26], [Pr. PD28], and [Pr. PD47]. Doing so will cause the drive unit to become servo-off when an instantaneous power failure occurs.
 - RS-485 communication is available with drive units manufactured in January 2015 or later.
 - The safety level depends on the setting value of [Pr. PF18 STO diagnosis error detection time] and whether STO input diagnosis by TOFB output is performed or not. For details, refer to the Function column of [Pr. PF18] in section 5.2.6 of "MR-J4-_A_(-RJ) Servo Amplifier Instruction Manual".
 - Follow the restrictions in section 2.5 when using this product at altitude exceeding 1000 m and up to 2000 m above sea level.

1. FUNCTIONS AND CONFIGURATION

(b) 400 V class

Model MR-J4-DU_(-RJ)		30KA4	37KA4	45KA4	55KA4
Output	Rated voltage	3-phase 323 V AC			
	Rated current [A]	87	102	131	143
Main circuit power supply input		The main circuit power of the drive unit is supplied by the converter unit.			
Control circuit power supply input	Voltage/Frequency	1-phase 380 V AC to 480 V AC, 50 Hz/60 Hz			
	Rated current [A]	0.2			
	Permissible voltage fluctuation	1-phase 323 V AC to 528 V AC			
	Permissible frequency fluctuation	Within $\pm 5\%$			
	Power consumption [W]	45			
	Inrush current [A]	Refer to section 5.4.3.			
Interface power supply	Voltage	24 V DC $\pm 10\%$			
	Current capacity [A]	0.5 (including CN8 connector signals) (Note 1)			
Control method		Sine-wave PWM control, current control method			
Dynamic brake		External option (Note 5, 7)			
Fully closed loop control		Compatible			
Load-side encoder interface (Note 6)		Mitsubishi Electric high-speed serial communication			
Communication function		USB: connection to a personal computer or others (MR Configurator2-compatible)			
		RS-422/RS-485: 1 : n communication (up to 32 axes)			
Encoder output pulses		Compatible (A/B/Z-phase pulse)			
Analog monitor		Two channels			
Position control mode	Max. input pulse frequency	4 Mpulses/s (for differential receiver) (Note 4), 200 kpulses/s (for open collector)			
	Positioning feedback pulse	Encoder resolution (resolution per servo motor revolution): 22 bits			
	Command pulse multiplying factor	Electronic gear A/B multiple, A:1 to 16777215, B:1 to 16777215, $1/10 < A/B < 4000$			
	In-position range setting	0 pulse to ± 65535 pulses (command pulse unit)			
	Error excessive	± 3 revolutions			
	Torque limit	Set with parameter or external analog input (0 V DC to +10 V DC/maximum torque)			
Speed control mode	Speed control range	Analog speed command 1: 2000, internal speed command 1: 5000			
	Analog speed command input	0 to ± 10 V DC/rated speed (The speed at 10 V is changeable with [Pr. PC12].)			
	Speed fluctuation ratio	$\pm 0.01\%$ or less (load fluctuation 0% to 100%), 0% (power fluctuation $\pm 10\%$), $\pm 0.2\%$ or less (ambient temperature $25\text{ }^{\circ}\text{C} \pm 10\text{ }^{\circ}\text{C}$) when using analog speed command			
	Torque limit	Set with parameter or external analog input (0 V DC to +10 V DC/maximum torque)			
Torque control mode	Analog torque command input	0 V DC to ± 8 V DC/maximum torque (input impedance 10 k Ω to 12 k Ω)			
	Speed limit	Set by parameter setting or external analog input (0 V DC to 10 V DC/rated speed)			
Positioning mode		Refer to section 1.1 of "MR-J4-_A_-RJ Servo Amplifier Instruction Manual (Positioning Mode)" The positioning mode is available with MR-J4-DU_A_-RJ drive units with software version B3 or later.			
Protective functions		Overcurrent shut-off, overload shut-off (electronic thermal), servo motor overheat protection, encoder error protection, undervoltage protection, instantaneous power failure protection, overspeed protection, and error excessive protection			
Functional safety		STO (IEC/EN 61800-5-2)			

1. FUNCTIONS AND CONFIGURATION

Model MR-J4-DU_(-RJ)		30KA4	37KA4	45KA4	55KA4
Safety performance	Standards certified by CB (Note 9)	EN ISO 13849-1 category 3 PL e, IEC 61508 SIL 3, EN 62061 SIL CL3, EN 61800-5-2			
	Response performance	8 ms or less (STO input off → energy shut off)			
	Test pulse input (STO) (Note 3)	Test pulse interval: 1 Hz to 25 Hz Test pulse off time: Up to 1 ms			
	Mean time to dangerous failure (MTTFd)	MTTFd ≥ 100 [years] (314a)			
	Diagnostic coverage (DC)	DC = Medium, 97.6 [%]			
	Probability of dangerous Failure per Hour (PFH)	6.4×10^{-9} [1/h]			
Compliance with global standards	CE marking	LVD: EN 61800-5-1 EMC: EN 61800-3 MD: EN ISO 13849-1, EN 61800-5-2, EN 62061			
	UL standard	UL 508C			
Structure (IP rating)		Force cooling, open (IP20) (Note 3)			
Environment	Ambient temperature	Operation	0 °C to 55 °C (non-freezing)		
		Storage	-20 °C to 65 °C (non-freezing)		
	Ambient humidity	Operation	5 %RH to 90 %RH (non-condensing)		
		Storage			
	Ambience	Indoors (no direct sunlight), free from corrosive gas, flammable gas, oil mist, dust, and dirt			
	Altitude	2000 m or less above sea level (Note 10)			
Vibration resistance	5.9 m/s ² , at 10 Hz to 55 Hz (X, Y, Z axes)				
Mass	[kg]	16		21	

- Note
- 0.5 A is the value applicable when all I/O signals are used. The current capacity can be decreased by reducing the number of I/O points.
 - Test pulse is a signal which instantaneously turns off a signal to the drive unit at a constant period for external circuit to self-diagnose.
 - Except for the terminal block.
 - 1 Mpulse/s or lower commands are supported in the initial setting. When inputting commands between over 1 Mpulse/s and 4 Mpulses/s, change the setting in [Pr. PA13].
 - Use an external dynamic brake for this drive unit. Failure to do so will cause an accident because the servo motor does not stop immediately but coasts at emergency stop. Ensure the safety in the entire equipment. For wiring of the external dynamic brake, refer to section 8.3.
 - The MR-J4-DU_A drive unit is compatible only with the two-wire type. The MR-J4-DU_A-RJ drive unit is compatible with the two-wire type, four-wire type, and A/B/Z-phase differential output method. Refer to section 1.1 for details.
 - The external dynamic brake cannot be used for compliance with SEMI-F47 standard. Do not assign DB (Dynamic brake interlock) with [Pr. PD23] to [Pr. PD26], [Pr. PD28], and [Pr. PD47]. Doing so will cause the drive unit to become servo-off when an instantaneous power failure occurs.
 - RS-485 communication is available with drive units manufactured in January 2015 or later.
 - The safety level depends on the setting value of [Pr. PF18 STO diagnosis error detection time] and whether STO input diagnosis by TOFB output is performed or not. For details, refer to the Function column of [Pr. PF18] in section 5.2.6 of "MR-J4-A_(-RJ) Servo Amplifier Instruction Manual".
 - Follow the restrictions in section 2.5 when using this product at altitude exceeding 1000 m and up to 2000 m above sea level.

1. FUNCTIONS AND CONFIGURATION

1.5 Function list

For the drive unit functions not mentioned in this section, refer to section 1.5 of "MR-J4-_B_(-RJ) Servo Amplifier Instruction Manual" for MR-J4-DU_B_(-RJ) drive unit and "MR-J4-_A_(-RJ) Servo Amplifier Instruction Manual" for MR-J4-DU_A_(-RJ) drive unit.

Function	Description	Supported model			
		MR-J4-DU_A_(-RJ)	MR-J4-DU_B_(-RJ)	MR-J4-_A_(-RJ)	MR-J4-_B_(-RJ)
Power monitoring function	This function calculates the power running energy and the regenerative power from the data in the servo amplifier such as speed and current. MR Configurator2 is necessary for this function. In principal, when the drive unit and servo amplifier are used with the converter unit, an error of approximately $\pm 15\%$ may occur between the calculated value and the value measured by your power measuring instrument.	○	○	○	○
MR-CV_ power regeneration converter unit	MR-CV_ power regeneration converter unit returns regenerative power generated during deceleration of the servo motor back to the power supply, and share a common bus voltage with multiple MR-J4-DU_B_(-RJ) drive units and MR-J4-_B_(-RJ) servo amplifiers. MR-CV_ is compatible with MR-J4-DU_B_(-RJ) drive units and MR-J4-_B_(-RJ) servo amplifiers with software version C5 or later. Check the software version with MR Configurator2.	/	○	/	○
MR-CR_ resistance regeneration converter unit	MR-CR_ resistance regeneration converter unit consumes regenerative power generated during deceleration of the servo motor with the regenerative resistor.	○	○	/	/

1. FUNCTIONS AND CONFIGURATION

1.6 Configuration including peripheral equipment

1.6.1 MR-CV_ power regeneration converter unit

The diagram shows MR-J4-DU30KB4 and MR-J4-DU37KB4. The interface connection of the drive unit is the same as that of 22 kW or less servo amplifier. Refer to each servo amplifier instruction manual.

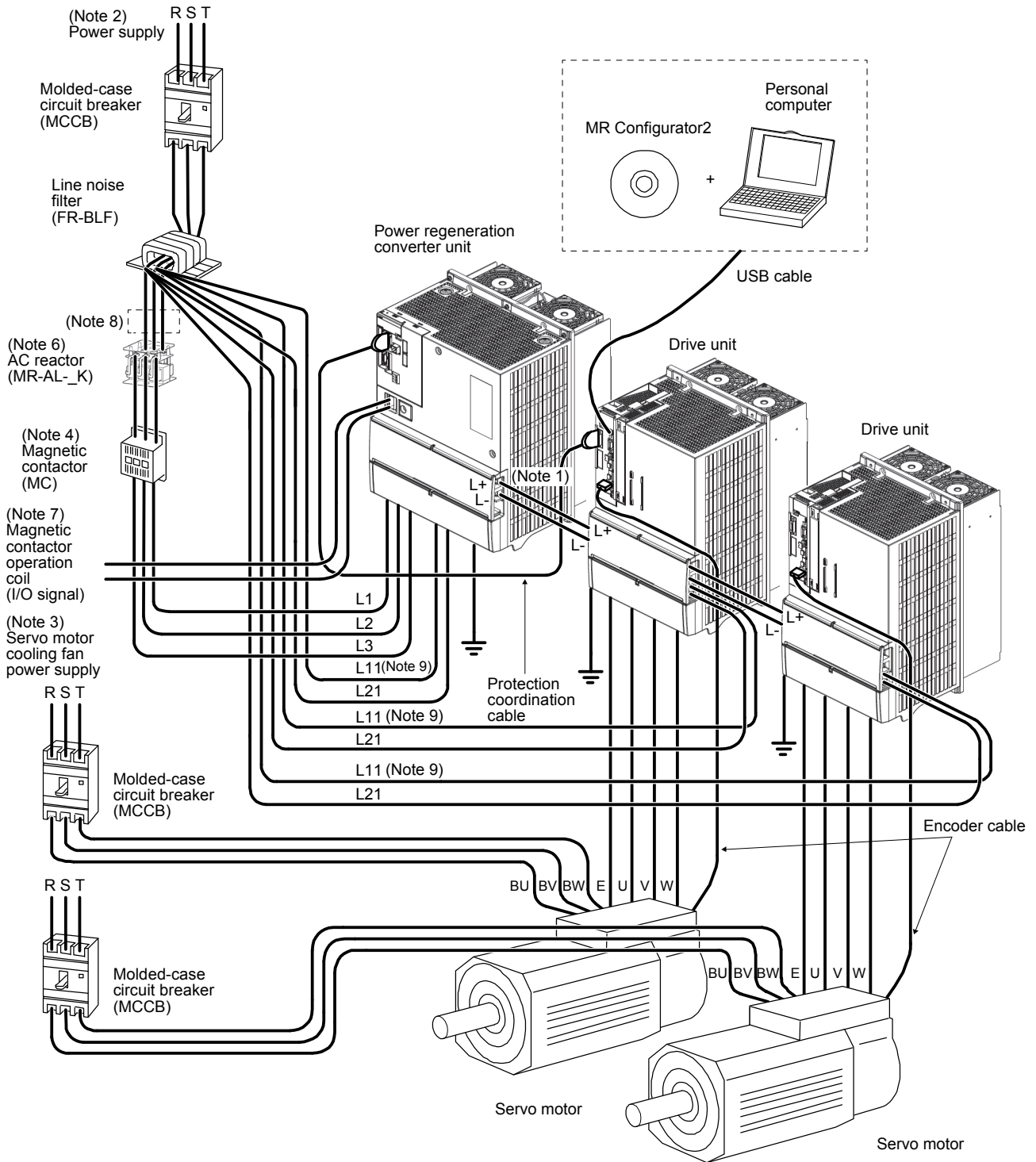

1. FUNCTIONS AND CONFIGURATION

- Note
1. In the actual connection, the power regeneration converter unit is closely mounted to the drive unit.
 2. For the power supply specifications, refer to section 1.4.
 3. For specifications of the cooling fan power supply, refer to "Servo Motor Instruction Manual (Vol. 3)".
 4. An bus voltage may drop, depending on the main circuit voltage and operation pattern, causing a dynamic brake deceleration during a forced stop deceleration. When dynamic brake deceleration is not required, delay the time to turn off the magnetic contactor.
 5. Install an overcurrent protection device (molded-case circuit breaker, fuse, or others) to protect the branch circuit. (Refer to section 8.5.)
 6. Be sure to install an MR-AL-_AC reactor.
 7. For the driving output of the magnetic contactor, refer to section 3.2.
 8. When using the same power supply for the main circuit and cooling fan for MR-CV_, do not supply power between the MR-CV_ and AC reactor or to the inductive load from the secondary side of the magnetic contactor. Connect them closer to the power supply side than the broken line area.
 9. The control circuit power supply (L11/L21) can be connected by passing wiring. Refer to section 6.8 for the wire size and the selection of the overcurrent protection device.

1. FUNCTIONS AND CONFIGURATION

1.6.2 MR-CR_ resistance regeneration converter unit

The diagram shows MR-J4-DU30KB4 and MR-J4-DU37KB4. The interface connection of MR-J4-DU_(-RJ) is the same as that of MR-J4_(-RJ). Refer to each servo amplifier instruction manual.

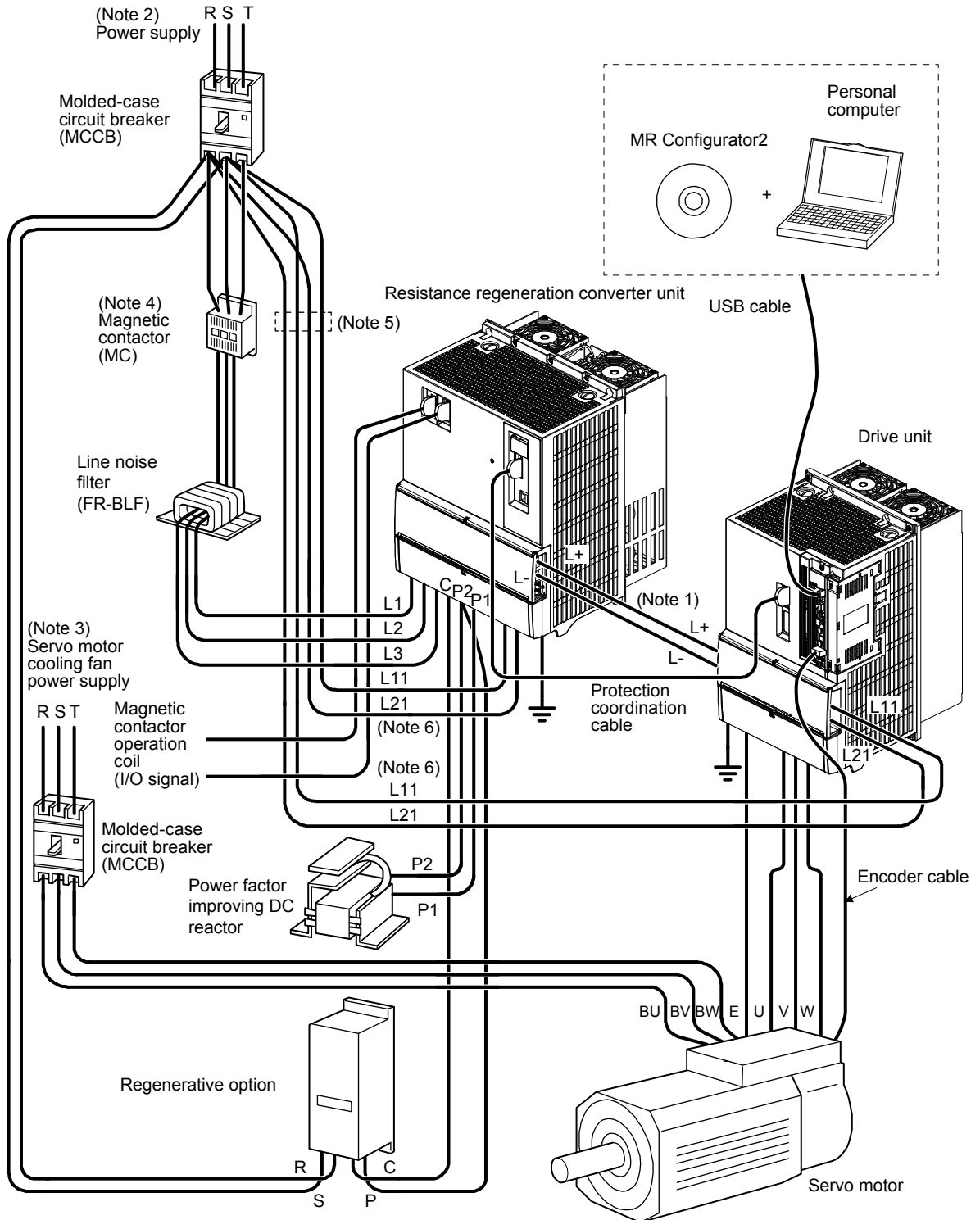

1. FUNCTIONS AND CONFIGURATION

- Note
1. The bus bars on L+ and L- for connecting the resistance regeneration converter unit to the drive unit are standard accessories. In the actual connection, the resistance regeneration converter unit is closely mounted to the drive unit.
 2. For the power supply specifications, refer to section 1.4.
 3. For specifications of the cooling fan power supply, refer to "Servo Motor Instruction Manual (Vol. 3)".
 4. An bus voltage may drop, depending on the main circuit voltage and operation pattern, causing a dynamic brake deceleration during a forced stop deceleration. When dynamic brake deceleration is not required, delay the time to turn off the magnetic contactor.
 5. Install an overcurrent protection device (molded-case circuit breaker, fuse, or others) to protect the branch circuit. (Refer to section 8.5.)
 6. The control circuit power supply (L11/L21) can be connected by passing wiring. Refer to section 6.8 for the wire size and the selection of the overcurrent protection device.

2. INSTALLATION

2. INSTALLATION

⚠ WARNING ● To prevent electric shock, ground each equipment securely.

⚠ CAUTION

- Stacking in excess of the specified number of product packages is not allowed.
- Do not hold the front cover, cables, or connectors when carrying the converter unit and drive unit. Otherwise, it may drop.
- Install the equipment on incombustible material. Installing them directly or close to combustibles will lead to a fire.
- Install the converter unit, the drive unit, and the servo motor in a load-bearing place in accordance with the Instruction Manual.
- Do not get on or put heavy load on the equipment. Otherwise, it may cause injury.
- Use the equipment within the specified environment. For the environment, refer to section 1.4.
- Provide adequate protection to prevent screws and other conductive matter, oil and other combustible matter from entering the converter unit and the drive unit.
- Do not block the intake and exhaust areas of the converter unit and the drive unit. Otherwise, it may cause a malfunction.
- Do not drop or apply heavy impact on the converter units, the drive units, and the servo motors. Otherwise, it may cause injury, malfunction, etc.
- Do not install or operate the converter unit and the drive unit which have been damaged or have any parts missing.
- When the product has been stored for an extended period of time, contact your local sales office.
- When handling the converter unit and the drive unit, be careful with the sharp edges of the converter unit and drive unit.
- The converter unit and the drive unit must be installed in a metal cabinet.
- When fumigants that contain halogen materials, such as fluorine, chlorine, bromine, and iodine, are used for disinfecting and protecting wooden packaging from insects, they cause a malfunction when entering our products. Please take necessary precautions to ensure that remaining materials from fumigant do not enter our products, or treat packaging with methods other than fumigation, such as heat treatment. Additionally, disinfect and protect wood from insects before packing the products.

The following items are the same as those for MR-J4-_-(-RJ). For the details of the items, refer to each chapter/section indicated in the detailed explanation field. "MR-J4-_B_" means "MR-J4-_B_(-RJ) Servo Amplifier Instruction Manual". "MR-J4-_A_" means "MR-J4-_A_(-RJ) Servo Amplifier Instruction Manual".

Model	Item	Detailed explanation
MR-J4-DU_B_(-RJ)	Encoder cable stress	MR-J4-_B_ section 2.3
	SSCNET III cable laying	MR-J4-_B_ section 2.4
MR-J4-DU_A_(-RJ)	Encoder cable stress	MR-J4-_A_ Section 2.3

2. INSTALLATION

2.1 Installation direction and clearances



CAUTION

- The equipment must be installed in the specified direction. Otherwise, it may cause a malfunction.
- Maintain specified clearances between the converter unit/drive unit and the inner surfaces of a control cabinet or other equipment. Otherwise, it may cause a malfunction.

2.1.1 When using MR-CV_ power regeneration converter unit

POINT

- Make sure to connect a drive unit to the right side of a power regeneration converter unit as shown in the diagram.

(1) Installation

(a) MR-CV_ power regeneration converter unit/MR-J4-DU_B_ drive unit

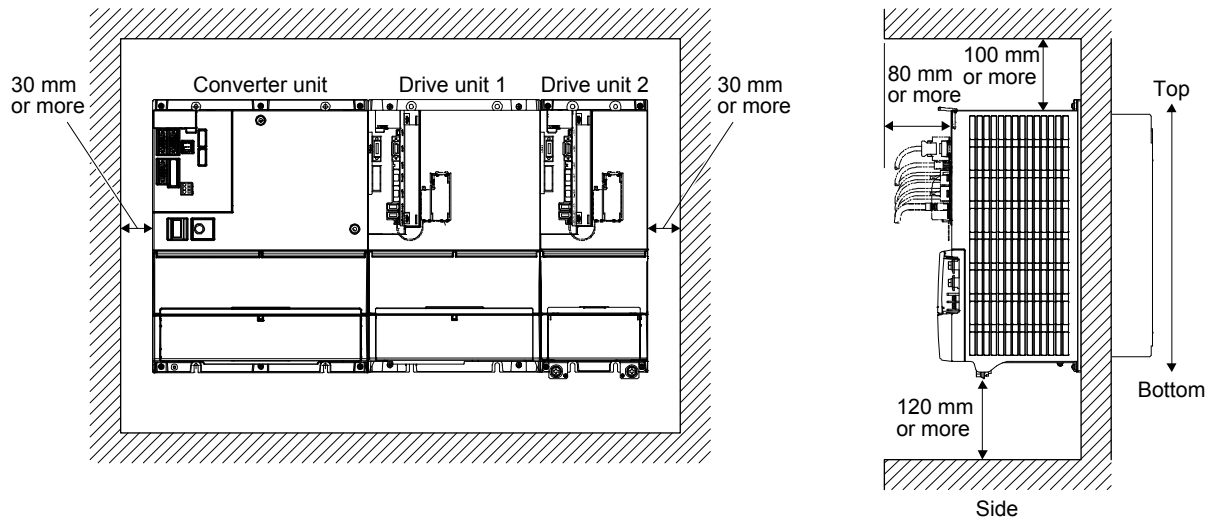

2. INSTALLATION

- (b) MR-CV_ power regeneration converter unit/MR-J4-DU_B_ drive unit/MR-J4-_B_ servo amplifier
Keep the wiring length between L+/L- of the power regeneration converter unit and P4/N- of the servo amplifier 1.5 m or longer, and total wiring length 5 m or shorter.

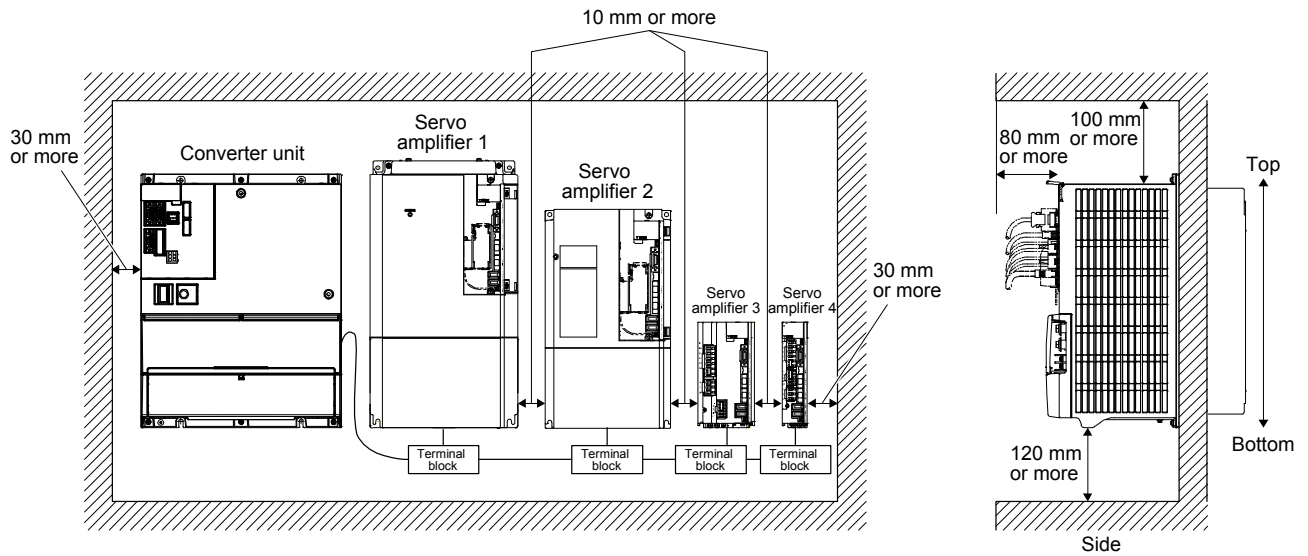

2. INSTALLATION

(2) Mounting hole process drawing

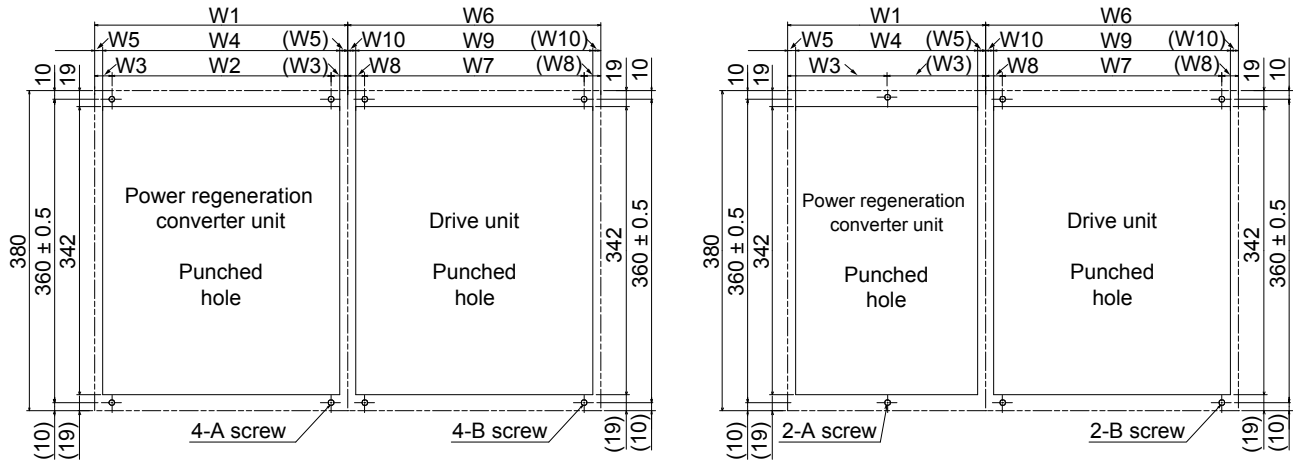

For MR-CV_ 30 kW or more

For MR-CV_ 18 kW or less

Drive unit	Variable dimensions [mm]										Screw size	
	W1	W2	W3	W4	W5	W6	W7	W8	W9	W10	A	B
MR-CV11K MR-CV18K MR-CV11K4 MR-CV18K4	90		45	82	4						M5	
MR-CV30K MR-CV37K MR-CV45K MR-CV30K4 MR-CV37K4 MR-CV45K4	150	60 ± 0.5	45	142	4						M5	
MR-CV55K MR-CV55K4 MR-CV75K4	300	180 ± 0.5	60	282	9						M5	
MR-J4-DU30KB(-RJ) MR-J4-DU37KB(-RJ) MR-J4-DU45KB4(-RJ) MR-J4-DU55KB4(-RJ)						300	260 ± 0.5	20	281	9.5		M6
MR-J4-DU900B(-RJ) MR-J4-DU11KB(-RJ) MR-J4-DU900B4(-RJ) MR-J4-DU11KB4(-RJ)						150	60 ± 0.5	45	142	4		M5
MR-J4-DU15KB(-RJ) MR-J4-DU22KB(-RJ) MR-J4-DU15KB4(-RJ) MR-J4-DU22KB4(-RJ) MR-J4-DU30KB4(-RJ) MR-J4-DU37KB4(-RJ)						240	120 ± 0.5	60	222	9		M5

2. INSTALLATION

2.1.2 When using MR-CR_ resistance regeneration converter unit

(1) Installation

POINT
<ul style="list-style-type: none"> ● Make sure to connect a drive unit to the right side of a resistance regeneration converter unit as shown in the diagram.

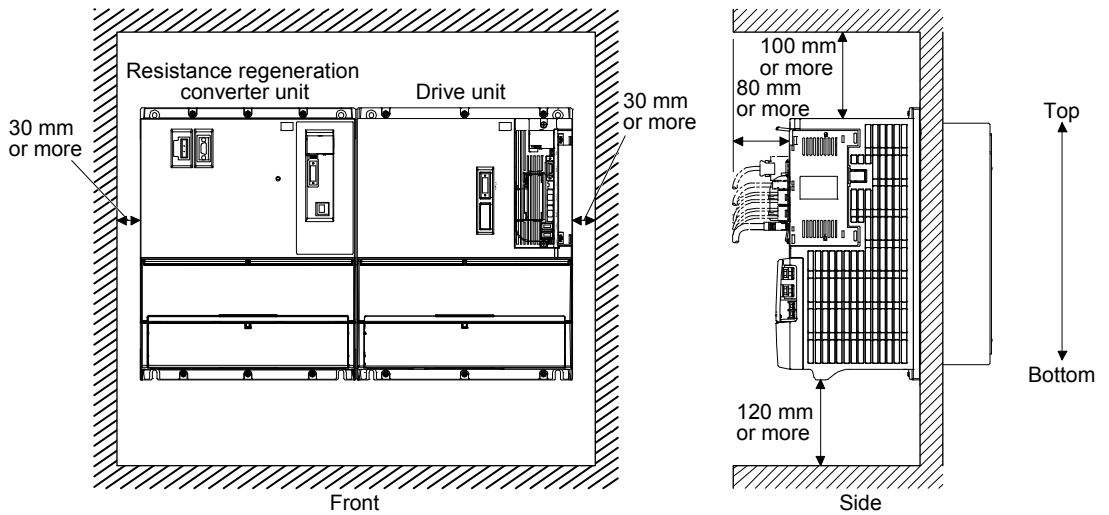

(2) Mounting hole process drawing

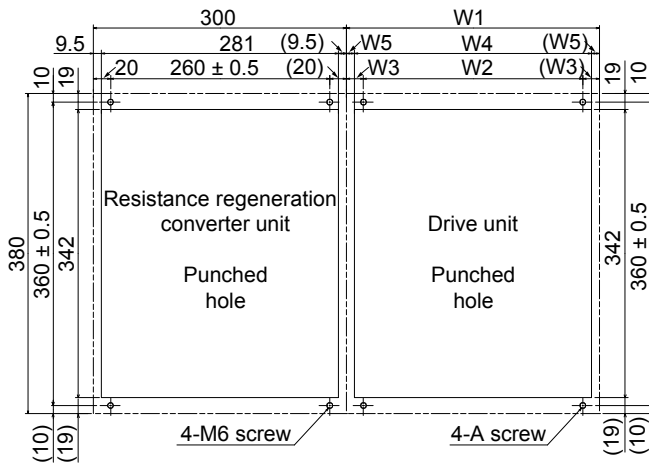

Resistance regeneration converter unit Drive unit	Variable dimensions [mm]					Screw size A
	W1	W2	W3	W4	W5	
MR-J4-DU30K_(-RJ) MR-J4-DU37K_(-RJ) MR-J4-DU45K_4(-RJ) MR-J4-DU55K_4(-RJ)	300	260 ± 0.5	20	281	9.5	M6
MR-J4-DU30K_4(-RJ) MR-J4-DU37K_4(-RJ)	240	120 ± 0.5	60	222	9	M5

(3) Others

When using heat generating equipment such as the regenerative option, install them with full consideration of heat generation so that the converter unit and drive unit are not affected. Install the converter unit and drive unit on a perpendicular wall in the correct vertical direction.

2. INSTALLATION

2.2 Keeping out of foreign materials

- (1) When drilling in the cabinet, prevent drill chips and wire fragments from entering the converter unit and the drive unit.
- (2) Prevent oil, water, metallic dust, etc. from entering the converter unit and the drive unit through openings in the cabinet or a cooling fan installed on the ceiling.
- (3) When installing the cabinet in a place where toxic gas, dirt, and dust exist, conduct an air purge (force clean air into the cabinet from outside to make the internal pressure higher than the external pressure) to prevent such materials from entering the cabinet.

2.3 Inspection items



WARNING

- Before starting maintenance and/or inspection, turn off the power and wait for 20 minutes or more until the charge lamp turns off. Then, confirm that the voltage between L+ and L- is safe with a voltage tester and others. Otherwise, an electric shock may occur. In addition, when confirming whether the charge lamp is off or not, be sure to look at the lamp from the front of the converter unit.
- To avoid an electric shock, only qualified personnel should attempt inspections. For repair and parts replacement, contact your local sales office.



CAUTION

- Do not perform insulation resistance test on the converter unit and the drive unit. Otherwise, it may cause a malfunction.
- Do not disassemble and/or repair the equipment on customer side.

It is recommended that the following points periodically be checked.

- (1) Check for loose terminal block screws. Retighten any loose screws.
- (2) Check for scratches and cracks of cables and the like. Inspect them periodically according to operating conditions especially when the servo motor is movable.
- (3) Check that the connectors are securely connected to the converter unit and the drive unit.
- (4) Check that the wires are not coming off from the connector.
- (5) Check for dust accumulation on the converter unit and the drive unit.
- (6) Check for unusual noise generated from the converter unit and the drive unit.
- (7) Make sure that the emergency stop circuit operates properly such that an operation can be stopped immediately and a power is shut off by the emergency stop switch.

2. INSTALLATION

2.4 Parts having service life

Service life of the following parts is listed below. However, the service life varies depending on operating methods and environment. If any fault is found in the parts, they must be replaced immediately regardless of their service life. For parts replacement, please contact your local sales office.

Part name	Life guideline
Smoothing capacitor	10 years
Relay	Number of power-on, forced stop by EM1 (Forced stop 1), controller forced stop, and on/off for STO: 100,000 times
Cooling fan	10,000 hours to 30,000 hours (2 years to 3 years)
Absolute position battery	Refer to each servo amplifier instruction manual.

(1) Smoothing capacitor

The characteristic of smoothing capacitor is deteriorated due to ripple currents, etc. The life of the capacitor greatly depends on ambient temperature and operating conditions. The capacitor will reach the end of its life in 10 years of continuous operation in air-conditioned environment (ambient temperature of 40 °C or less).

(2) Relays

Contact faults will occur due to contact wear arisen from switching currents. Relays reach the end of their lives when the number of power-on, forced stop by EM1 (Forced stop 1), controller forced stop, and on/off for STO while the servo motor is stopped under servo-off state reaches 100,000 times. However, the lives of relays may depend on the power supply capacity.

(3) Cooling fan

The cooling fan bearings reach the end of their lives in 10,000 hours to 30,000 hours. Normally, therefore, the cooling fan must be replaced in a few years of continuous operation as a guideline. If unusual noise or vibration is found during inspection, the cooling fan must also be replaced. The life indicates under the yearly average ambient temperature of 40 °C, free from corrosive gas, flammable gas, oil mist, dust and dirt.

2. INSTALLATION

2.5 Restrictions when using this product at altitude exceeding 1000 m and up to 2000 m above sea level

(1) Effective load ratio and regenerative load ratio

As heat dissipation effects decrease in proportion to decreasing air density, use the product within the effective load ratio and regenerative load ratio shown in the following figure.

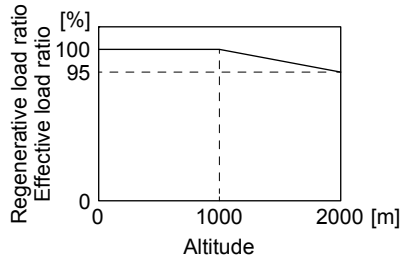

(2) Input voltage

Generally, a withstand voltage decreases as the altitude increases; however, there is no restriction on the withstand voltage. Use in the same manner as in 1000 m or less. (Refer to section 1.4.)

(3) Parts having service life

(a) Smoothing capacitor

The capacitor will reach the end of its life in 10 years of continuous operation in air-conditioned environment (ambient temperature of 30 °C or less).

(b) Relay

There is no restriction. Use in the same manner as in 1000 m or less. (Refer to section 2.4.)

(c) Cooling fan of the converter unit/drive unit

There is no restriction. Use in the same manner as in 1000 m or less. (Refer to section 2.4.)

3. MR-CV_ POWER REGENERATION CONVERTER UNIT

3. MR-CV_ POWER REGENERATION CONVERTER UNIT

POINT
●MR-CV_ power regeneration converter unit can be used in a combination with MR-J4-DU_B_(-RJ) drive units and MR-J4-_B_(-RJ) servo amplifiers.

3. MR-CV_ POWER REGENERATION CONVERTER UNIT

3.1 Function block diagram

The function block diagram of this servo is shown below.

POINT

- The diagram shows the combination of the MR-J4-DU_B_-RJ drive unit and power regeneration converter unit as an example. The MR-J4-DU_B_ drive unit does not have the CN2L connector.

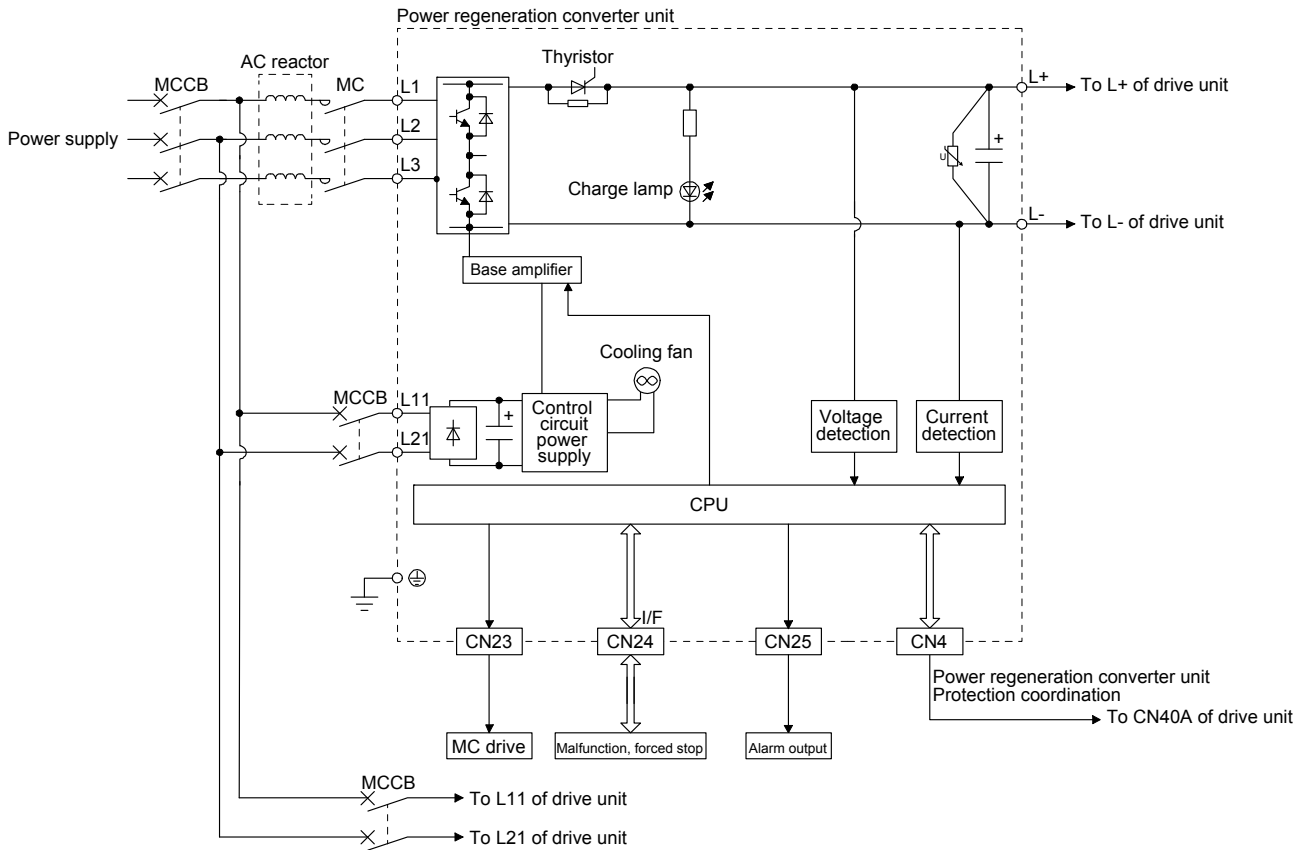

3. MR-CV_ POWER REGENERATION CONVERTER UNIT

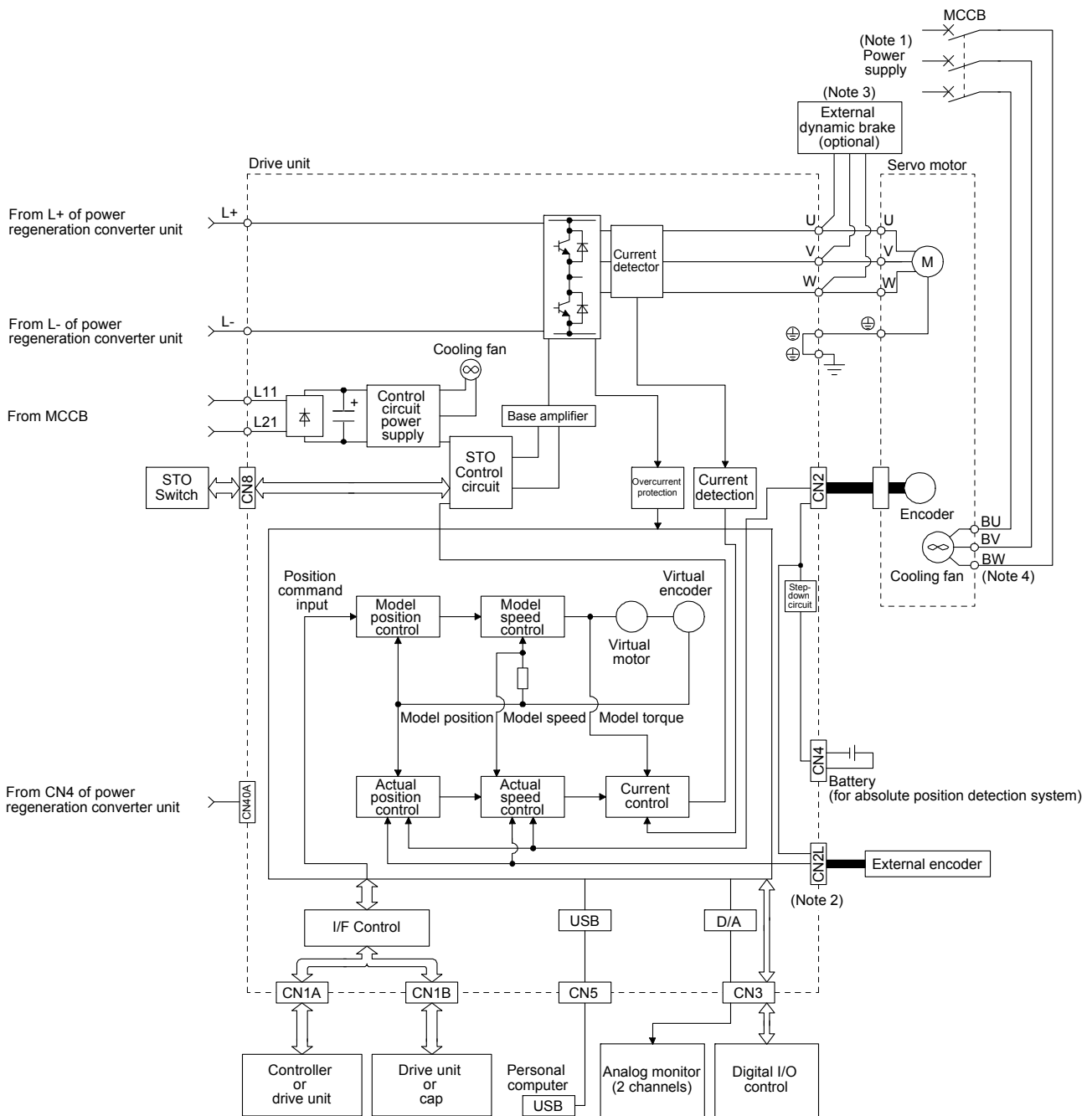

- Note 1. For specifications of the cooling fan power supply, refer to "Servo Motor Instruction Manual (Vol. 3)".
- Note 2. This is for the MR-J4-DU_B_-RJ drive unit. The MR-J4-DU_B_ drive unit does not have the CN2L connector.
- Note 3. Use an external dynamic brake for this drive unit. Failure to do so will cause an accident because the servo motor does not stop immediately but coasts at an alarm occurrence for which the servo motor does not decelerate to stop. Ensure the safety in the entire equipment. For wiring of the external dynamic brake, refer to section 8.3. For alarms in which the servo motor does not decelerate to stop, refer to chapter 6.
- Note 4. When using the same power supply for the main circuit and cooling fan for MR-CV_, do not supply power between the MR-CV_ and AC reactor or to the inductive load from the secondary side of the magnetic contactor.

3. MR-CV_ POWER REGENERATION CONVERTER UNIT

3.2 Structure (parts identification)

(1) MR-CV18K(4) or less

POINT

● The unit is shown with the terminal cover open. For opening or closing of the terminal cover, refer to section 4.2.2.

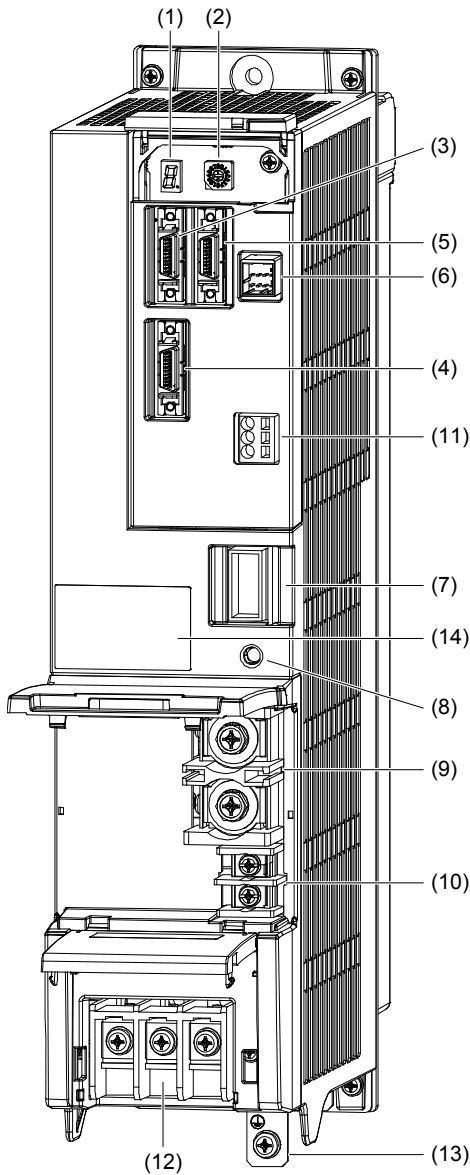

No.	Name/Application	Detailed explanation
(1)	Display The 1-digit, 7-segment LED display shows the power regeneration converter unit status and the alarm number.	Section 3.4.3
(2)	Converter setting rotary switch (SW1) Set the function of the power regeneration converter unit.	Section 3.4.3
(3)	Protection coordination connector (CN4) Connect to CN40A of the drive unit.	Section 3.3.1
(4)	Manufacturer setting connector (CN9) This is for manufacturer setting. Although the shape is similar to the protection coordination connector (CN4), do not connect anything including the protection coordination cable.	
(5)	Manufacturer setting connector (CN41) This is for manufacturer setting. Although the shape is similar to the protection coordination connector (CN4), do not connect anything including the protection coordination cable.	
(6)	I/O signal connector (CN24) Used to connect digital I/O signals.	Section 3.3.4
(7)	Magnetic contactor control connector (CNP23) Connect to the coil of the magnetic contactor.	Section 3.3.1 Section 3.3.3
(8)	Charge lamp When the main circuit is charged, this will light up. While this lamp is lit, do not reconnect the wires.	
(9)	L+/L- terminal (TE2) Connect to a drive unit with a bus bar.	Section 3.3.1
(10)	Control circuit terminal L11/L21 (TE3) Connect to the control circuit power supply.	Section 3.3.1
(11)	Alarm output connector (CN25) This connector, having a form C contact, outputs an alarm when the protective function of the power regeneration converter unit is activated and the power output to the drive unit is stopped.	Section 3.3.4
(12)	Main circuit terminal block (TE1) Connect to the input power supply.	Section 3.3.1
(13)	Protective earth (PE) terminal	Section 3.3.8
(14)	Rating plate	Section 1.2

3. MR-CV_ POWER REGENERATION CONVERTER UNIT

(2) MR-CV30K(4)/MR-CV37K(4)/MR-CV45K(4)

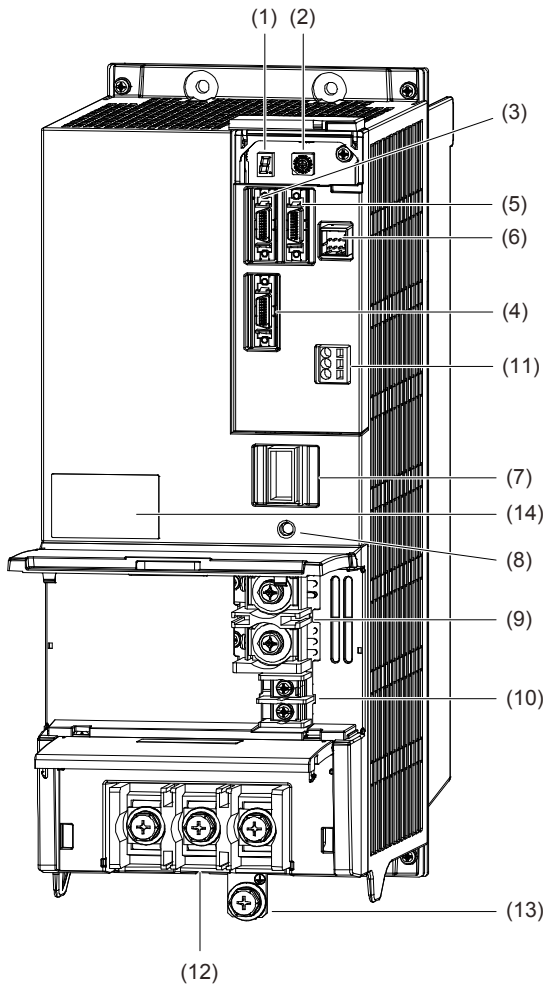

No.	Name/Application	Detailed explanation
(1)	Display The 1-digit, 7-segment LED display shows the power regeneration converter unit status and the alarm number.	Section 3.4.3
(2)	Converter setting rotary switch (SW1) Set the function of the power regeneration converter unit.	Section 3.4.3
3	Protection coordination connector (CN4) Connect to CN40A of the drive unit.	Section 3.3.1
(4)	Manufacturer setting connector (CN9) This is for manufacturer setting. Although the shape is similar to the protection coordination connector (CN4), do not connect anything including the protection coordination cable.	
(5)	Manufacturer setting connector (CN41) This is for manufacturer setting. Although the shape is similar to the protection coordination connector (CN4), do not connect anything including the protection coordination cable.	
(6)	I/O signal connector (CN24) Used to connect digital I/O signals.	Section 3.3.4
(7)	Magnetic contactor control connector (CNP23) Connect to the coil of the magnetic contactor.	Section 3.3.1 Section 3.3.3
(8)	Charge lamp When the main circuit is charged, this will light up. While this lamp is lit, do not reconnect the wires.	
(9)	L+/L- terminal (TE2) Connect to a drive unit with a bus bar.	Section 3.3.1
(10)	Control circuit terminal L11/L21 (TE3) Connect to the control circuit power supply.	Section 3.3.1
(11)	Alarm output connector (CN25) This connector, having a form C contact, outputs an alarm when the protective function of the power regeneration converter unit is activated and the power output to the drive unit is stopped.	Section 3.3.4
(12)	Main circuit terminal block (TE1) Connect to the input power supply.	Section 3.3.1
(13)	Protective earth (PE) terminal	Section 3.3.8
(14)	Rating plate	Section 1.2

3. MR-CV_ POWER REGENERATION CONVERTER UNIT

(3) MR-CV55K(4)/MR-CV75K4/MR-CV55K
The diagram shows MR-CV55K4.

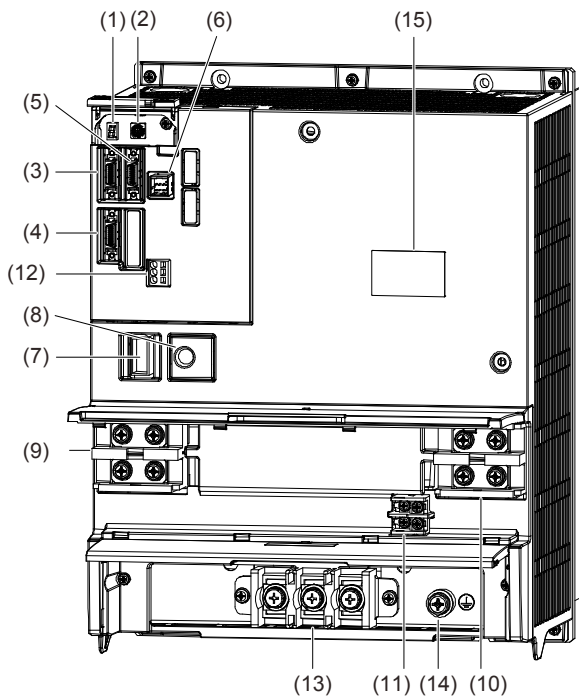

No.	Name/Application	Detailed explanation
(1)	Display The 1-digit, 7-segment LED display shows the power regeneration converter unit status and the alarm number.	Section 3.4.3
(2)	Converter setting rotary switch (SW1) Set the function of the power regeneration converter unit.	Section 3.4.3
(3)	Protection coordination connector (CN4) Connect to CN40A of the drive unit.	Section 3.3.1
(4)	Manufacturer setting connector (CN9) This is for manufacturer setting. Although the shape is similar to the protection coordination connector (CN4), do not connect anything including the protection coordination cable.	
(5)	Manufacturer setting connector (CN41) This is for manufacturer setting. Although the shape is similar to the protection coordination connector (CN4), do not connect anything including the protection coordination cable.	
(6)	I/O signal connector (CN24) Used to connect digital I/O signals.	Section 3.3.4
(7)	Magnetic contactor control connector (CNP23) Connect to the coil of the magnetic contactor.	Section 3.3.1 Section 3.3.3
(8)	Charge lamp When the main circuit is charged, this will light up. While this lamp is lit, do not reconnect the wires.	
(9)	Manufacturer setting terminal (TE2-1) This is for manufacturer setting. Leave this open.	
to 10	L+/L- terminal (TE2-2) Connect to a drive unit with a bus bar.	Section 3.3.1
(11)	Control circuit terminal L11/L21 (TE3) Connect to the control circuit power supply.	Section 3.3.1
(12)	Alarm output connector (CN25) This connector, having a form C contact, outputs an alarm when the protective function of the power regeneration converter unit is activated and the power output to the drive unit is stopped.	Section 3.3.4
(13)	Main circuit terminal block (TE1) Connect to the input power supply.	Section 3.3.1
(14)	Protective earth (PE) terminal	Section 3.3.8
(15)	Rating plate	Section 1.2

3. MR-CV_ POWER REGENERATION CONVERTER UNIT

3.3 Signals and wiring

⚠ WARNING

- Any person who is involved in wiring should be fully competent to do the work.
- Before wiring, turn off the power and wait for 20 minutes or more until the charge lamp turns off. Then, confirm that the voltage between L+ and L- is safe with a voltage tester or others. Otherwise, an electric shock may occur. In addition, when confirming whether the charge lamp is off or not, be sure to look at the lamp from the front of the power regeneration converter unit.
- Ground the power regeneration converter unit, drive unit, and servo motor securely.
- Do not attempt to wire the power regeneration converter unit, drive unit, and servo motor until they have been installed. Otherwise, it may cause an electric shock.
- The cables should not be damaged, stressed, loaded, or pinched. Otherwise, it may cause an electric shock.
- To avoid an electric shock, insulate the connections of the power supply terminals.

⚠ CAUTION

- Wire the equipment correctly and securely. Otherwise, the servo motor may operate unexpectedly, resulting in injury.
- Connect cables to the correct terminals. Otherwise, a burst, damage, etc., may occur.
- Ensure that polarity (+/-) is correct. Otherwise, a burst, damage, etc., may occur.
- The surge absorbing diode installed to the DC relay for control output should be fitted in the specified direction. Otherwise, the servo amplifier will malfunction and will not output signals, disabling the emergency stop and other protective circuits.

For sink output interface

For source output interface

- Use a noise filter, etc., to minimize the influence of electromagnetic interference. Electromagnetic interference may affect the electronic equipment used near the power regeneration converter unit and the drive unit.
- Do not modify the equipment.

The following items are the same as those for MR-J4-_-(-RJ). For the details of the items, refer to each chapter/section indicated in the detailed explanation field. "MR-J4-_B_" means "MR-J4-_B_(-RJ) Servo Amplifier Instruction Manual".

Model	Item	Detailed explanation
MR-J4-DU_B_(-RJ)	I/O signal connection example	MR-J4-_B_ section 3.2
	Forced stop deceleration function	MR-J4-_B_ section 3.6
	SSCNET III cable connection	MR-J4-_B_ section 3.9

3. MR-CV_ POWER REGENERATION CONVERTER UNIT

3.3.1 Connection example of power circuit

WARNING

- Insulate the connections of the power supply terminals. Otherwise, an electric shock may occur.

CAUTION

- Be sure to connect a magnetic contactor between the power supply and the main circuit power supply (L1/L2/L3) of the power regeneration converter unit, in order to configure a circuit that shuts off the power supply by the magnetic contactor. If the magnetic contactor is not connected, a large current keeps flowing and may cause a fire when the power regeneration converter unit or the drive unit malfunctions.
- Use ALM (Malfunction) to shut the power off. Not doing so may cause a fire when the power regeneration converter unit malfunctions and causes the AC reactor to overheat.
- The power regeneration converter unit has a built-in surge absorber (varistor) to reduce exogenous noise and to suppress lightning surge. Exogenous noise or lightning surge deteriorates the varistor characteristics, and the varistor may be damaged. To prevent a fire, use a molded-case circuit breaker or fuse for the input power supply.
- Check the power regeneration converter unit model, and then input proper voltage to the power regeneration converter unit power supply. If input voltage exceeds the upper limit, the power regeneration converter unit and the drive unit will break down.

POINT

- For drive units, EM2 has the same function as EM1 in the torque control mode.
- For the MR-J4-DU_B_(-RJ) drive units, do not shut off the control circuit power supply even if an alarm occurs. When the control circuit power supply is shut off, an optical module does not operate, and optical transmission of SSCNET III/H communication is interrupted. Therefore, the next servo amplifiers and drive units show "AA" on the display and shut off the base circuit, stopping the servo motors with the dynamic brake.

3. MR-CV_ POWER REGENERATION CONVERTER UNIT

(1) Magnetic contactor control connector (CNP23)

By enabling magnetic contactor drive output, the main circuit power supply can be shut off automatically when an alarm occurs in the power regeneration converter unit or the drive unit.

To enable magnetic contactor drive output, set the converter setting rotary switch (SW1) of the power regeneration converter unit to "0" or "4".

(a) When magnetic contactor drive output is enabled

Connecting the magnetic contactor control connector (CNP23) to the operating coil of the magnetic contactor enables to control the magnetic contactor.

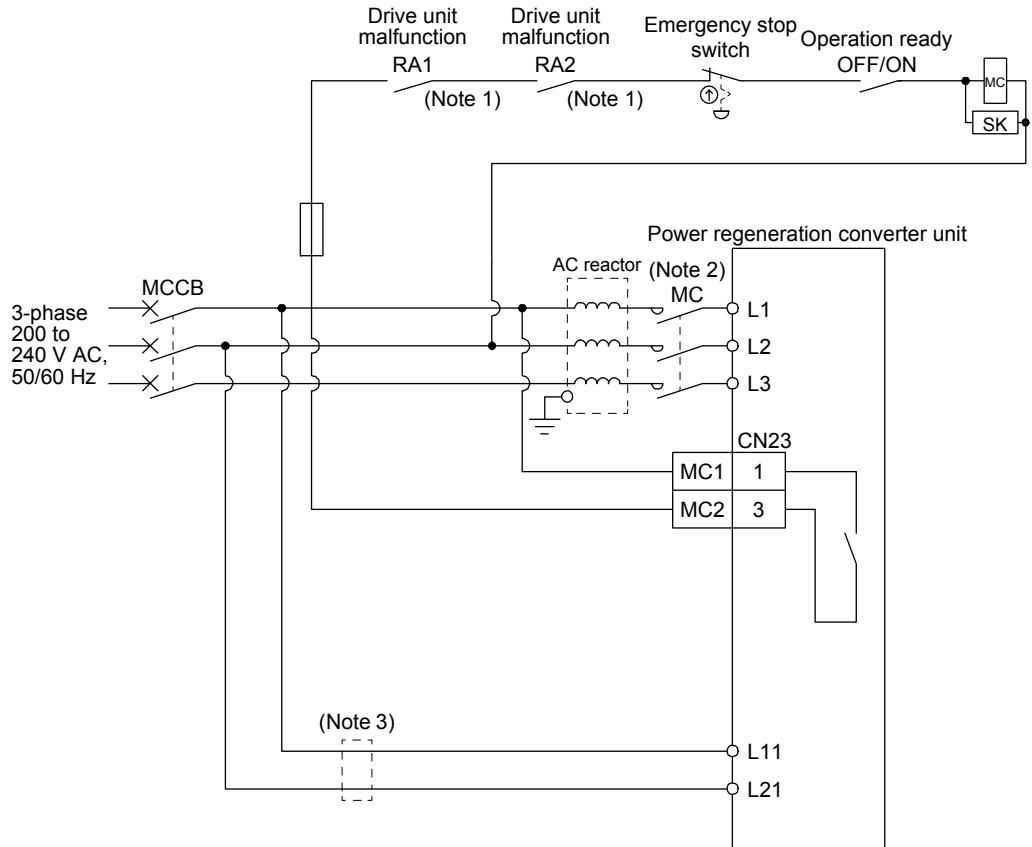

- Note
1. When multiple drive units are connected to a converter unit, configure a circuit that the forced stop of the servo system controller is inputted by an alarm signal of each drive unit, and create a sequence in which the states of all drive units will be ready-off if an alarm occurs in one of the drive units. When the state of the drive unit and servo amplifier is ready-off (forced stop state by the controller), the servo motor coasts. Set a dynamic brake to stop the servo motor.
 2. Use a magnetic contactor with an operation delay time (interval between current being applied to the coil until closure of contacts) of 80 ms or less. When one drive unit is connected, and the forced stop deceleration is enabled, a bus voltage may drop, depending on the main circuit voltage and operation pattern, causing dynamic brake deceleration during forced stop deceleration. When dynamic brake deceleration is not required, delay the time to turn off the magnetic contactor.
 3. Install an overcurrent protection device (molded-case circuit breaker, fuse, or others). (Refer to section 8.5.)

3. MR-CV_ POWER REGENERATION CONVERTER UNIT

When the power regeneration converter unit receives a start command from the drive unit, CNP23-1 pin (MC1) and CN23-3 pin (MC2) which are connected to the AC power supply will be shorted to supply a power to the control circuit of the magnetic contactor. When the control circuit power is supplied, the magnetic contactor turns on, and the main circuit power will be supplied to the power regeneration converter unit.

In the following cases, CN23-1 (MC1) and CN23-1 pin (MC2) in the power regeneration converter unit will be opened, and the main circuit power supply will be automatically shut off.

- 1) An alarm has occurred in the power regeneration converter unit.
 - 2) An alarm has occurred in the drive unit.
 - 3) The EM1 (forced stop) of the power regeneration converter unit was turned off.
 - 4) [AL. 95 STO warning] has occurred in the drive unit.
- (b) When magnetic contactor drive output is disabled
- The main circuit power supply does not shut off automatically even when an alarm occurs in the power regeneration converter unit or the drive unit. Therefore, configure an external circuit to shut off the main circuit power supply when an alarm is detected.

3. MR-CV_ POWER REGENERATION CONVERTER UNIT

(2) Wiring

(a) Connecting one drive unit to one power regeneration converter unit

1) When magnetic contactor drive output is enabled (factory setting)

POINT
● The power regeneration converter unit controls the magnetic contactor.
● Connect the power regeneration converter unit and the adjacent drive unit with MR-CUL06M protection coordination cable.
● Be sure to simultaneously turn on and off the control circuit power supplies of the power regeneration converter unit and the drive unit.

a) 200 V class

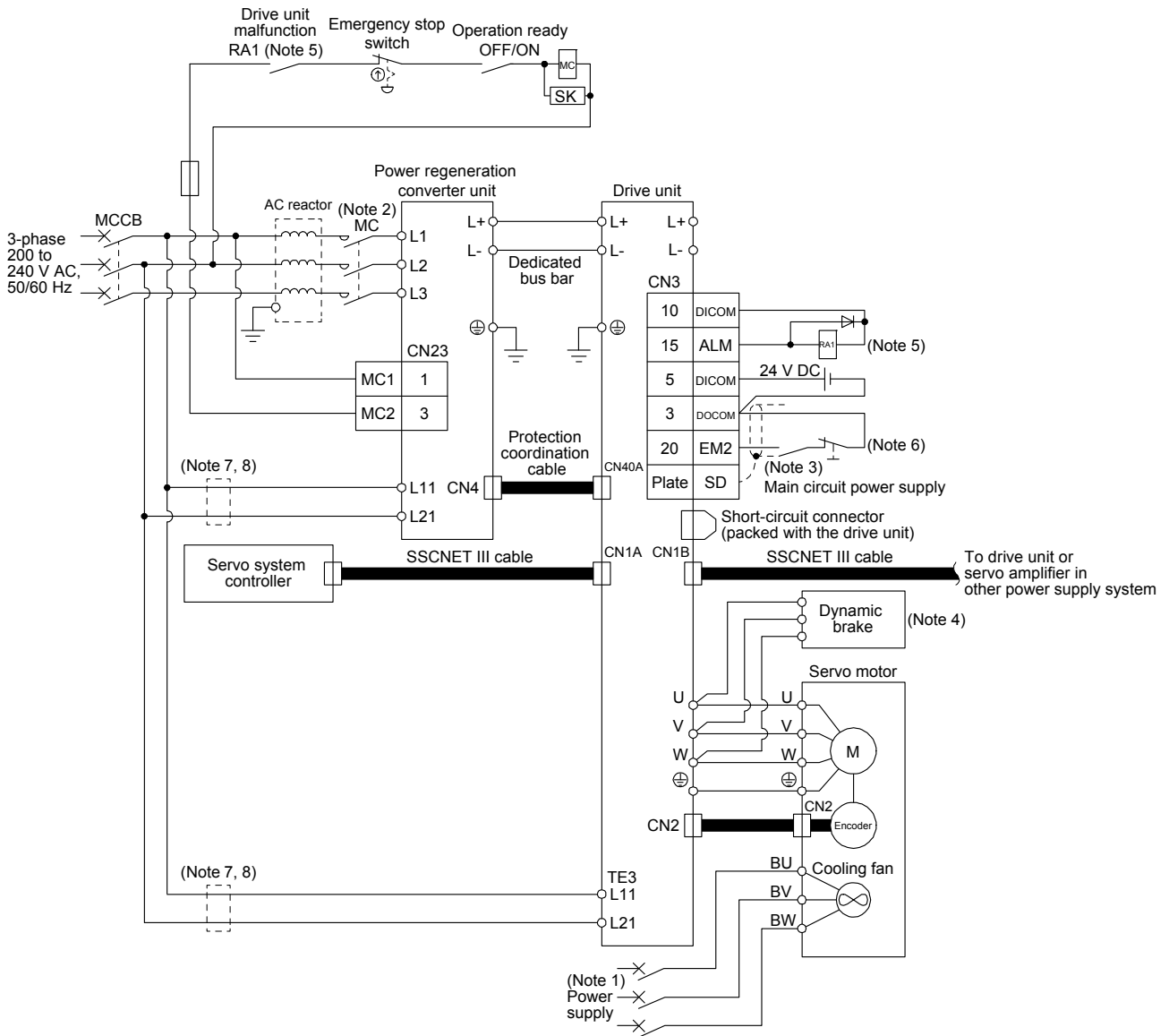

3. MR-CV_ POWER REGENERATION CONVERTER UNIT

- Note
1. For specifications of the cooling fan power supply, refer to "Servo Motor Instruction Manual (Vol. 3)". When using the same power supply for the main circuit and cooling fan for MR-CV_, do not supply power between the MR-CV_ and AC reactor or to the inductive load from the secondary side of the magnetic contactor.
 2. Use a magnetic contactor with an operation delay time (interval between current being applied to the coil until closure of contacts) of 80 ms or less. A bus voltage may drop, depending on the main circuit voltage and operation pattern, causing a dynamic brake deceleration during a forced stop deceleration.
 3. To prevent an unexpected restart of the drive unit, configure a circuit to turn off EM2 in the drive unit when the main circuit power is turned off.
 4. Use an external dynamic brake for this drive unit. Failure to do so will cause an accident because the servo motor does not stop immediately but coasts at an alarm occurrence for which the servo motor does not decelerate to stop. Ensure the safety in the entire equipment. For alarms for which the servo motor does not decelerate to stop, refer to chapter 6. For wiring of the external dynamic brake, refer to section 8.3. When using the external dynamic brake, assign DB (Dynamic brake interlock) to the CN3 connector pin with [Pr. PD07] to [Pr. PD09].
 5. Configure a sequence that will shut off the main circuit power when an alarm occurs.
 6. When EM2 is used to decelerate the servo motor to a stop, the converter unit shuts off the main circuit power supply with the protection coordination after the servo motor has stopped.
 7. Install an overcurrent protection device (molded-case circuit breaker, fuse, or others) to protect the branch circuit. (Refer to section 8.5.)
 8. The control circuit power supply (L11/L21) can be connected by passing wiring. Refer to section 6.8 for the wire size and the selection of the overcurrent protection device.

3. MR-CV_ POWER REGENERATION CONVERTER UNIT

b) 400 V class

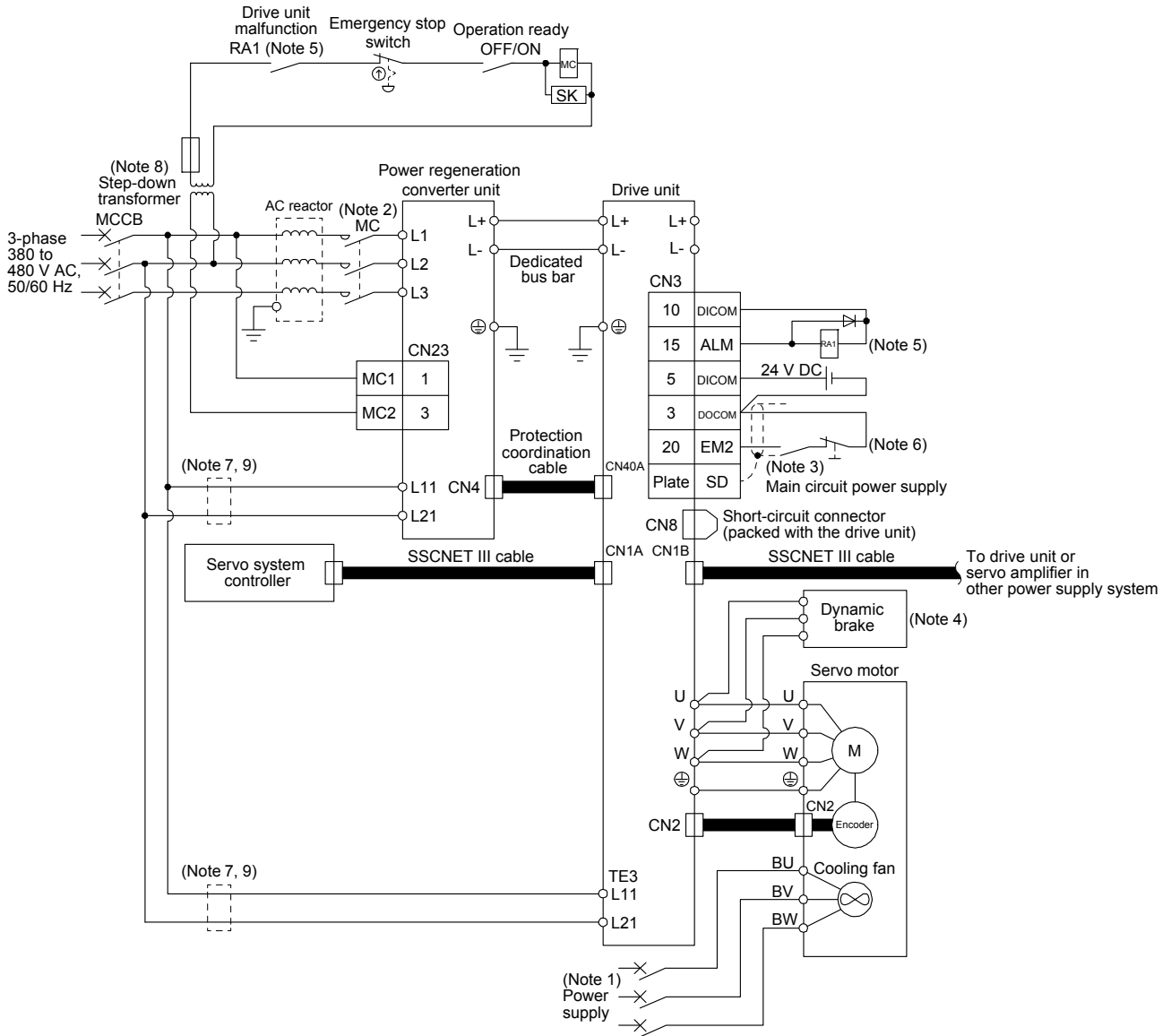

3. MR-CV_ POWER REGENERATION CONVERTER UNIT

- Note
1. For specifications of the cooling fan power supply, refer to "Servo Motor Instruction Manual (Vol. 3)". When using the same power supply for the main circuit and cooling fan for MR-CV_, do not supply power between the MR-CV_ and AC reactor or to the inductive load from the secondary side of the magnetic contactor.
 2. Use a magnetic contactor with an operation delay time (interval between current being applied to the coil until closure of contacts) of 80 ms or less. A bus voltage may drop, depending on the main circuit voltage and operation pattern, causing a dynamic brake deceleration during a forced stop deceleration.
 3. To prevent an unexpected restart of the drive unit, configure a circuit to turn off EM2 in the drive unit when the main circuit power is turned off.
 4. Use an external dynamic brake for this drive unit. Failure to do so will cause an accident because the servo motor does not stop immediately but coasts at an alarm occurrence for which the servo motor does not decelerate to stop. Ensure the safety in the entire equipment. For alarms for which the servo motor does not decelerate to stop, refer to chapter 6. For wiring of the external dynamic brake, refer to section 8.3. When using the external dynamic brake, assign DB (Dynamic brake interlock) to the CN3 connector pin with [Pr. PD07] to [Pr. PD09].
 5. Configure a sequence that will shut off the main circuit power when an alarm occurs.
 6. When EM2 is used to decelerate the servo motor to a stop, the converter unit shuts off the main circuit power supply with the protection coordination after the servo motor has stopped.
 7. Install an overcurrent protection device (molded-case circuit breaker, fuse, or others) to protect the branch circuit. (Refer to section 8.5.)
 8. A step-down transformer is required when the coil voltage of the magnetic contactor is 200 V class.
 9. The control circuit power supply (L11/L21) can be connected by passing wiring. Refer to section 6.8 for the wire size and the selection of the overcurrent protection device.

3. MR-CV_ POWER REGENERATION CONVERTER UNIT

2) When magnetic contactor drive output is disabled

POINT
● The power regeneration converter unit controls the magnetic contactor.
● Connect the power regeneration converter unit and the adjacent drive unit with MR-CUL06M protection coordination cable.
● Be sure to simultaneously turn on and off the control circuit power supplies of the power regeneration converter unit and the drive unit.

a) 200 V class

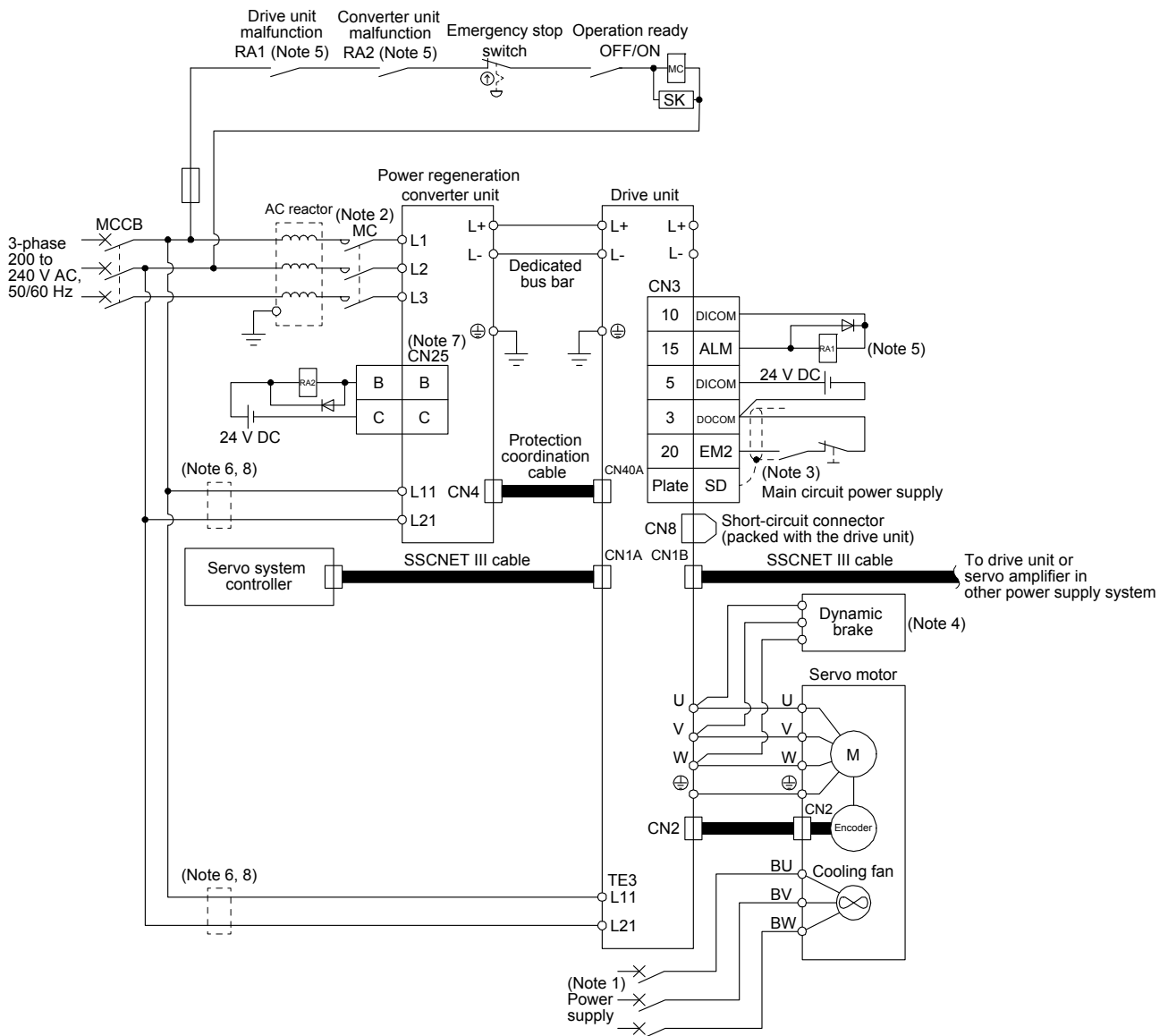

3. MR-CV_ POWER REGENERATION CONVERTER UNIT

- Note
1. For specifications of the cooling fan power supply, refer to "Servo Motor Instruction Manual (Vol. 3)". When using the same power supply for the main circuit and cooling fan for MR-CV_, do not supply power between the MR-CV_ and AC reactor or to the inductive load from the secondary side of the magnetic contactor.
 2. Use a magnetic contactor with an operation delay time (interval between current being applied to the coil until closure of contacts) of 80 ms or less. A bus voltage may drop, depending on the main circuit voltage and operation pattern, causing a dynamic brake deceleration during a forced stop deceleration.
 3. To prevent an unexpected restart of the drive unit, configure a circuit to turn off EM2 in the drive unit when the main circuit power is turned off.
 4. Use an external dynamic brake for this drive unit. Failure to do so will cause an accident because the servo motor does not stop immediately but coasts at an alarm occurrence for which the servo motor does not decelerate to stop. Ensure the safety in the entire equipment. For alarms for which the servo motor does not decelerate to stop, refer to chapter 6. For wiring of the external dynamic brake, refer to section 8.3. When using the external dynamic brake, assign DB (Dynamic brake interlock) to the CN3 connector pin with [Pr. PD07] to [Pr. PD09].
 5. Configure a sequence that will shut off the main circuit power when an alarm occurs.
 6. Install an overcurrent protection device (molded-case circuit breaker, fuse, or others) to protect the branch circuit. (Refer to section 8.5.)
 7. Connect to an error output (A/B/C) via a relay coil, etc.
 8. The control circuit power supply (L11/L21) can be connected by passing wiring. Refer to section 6.8 for the wire size and the selection of the overcurrent protection device.

3. MR-CV_ POWER REGENERATION CONVERTER UNIT

b) 400 V class

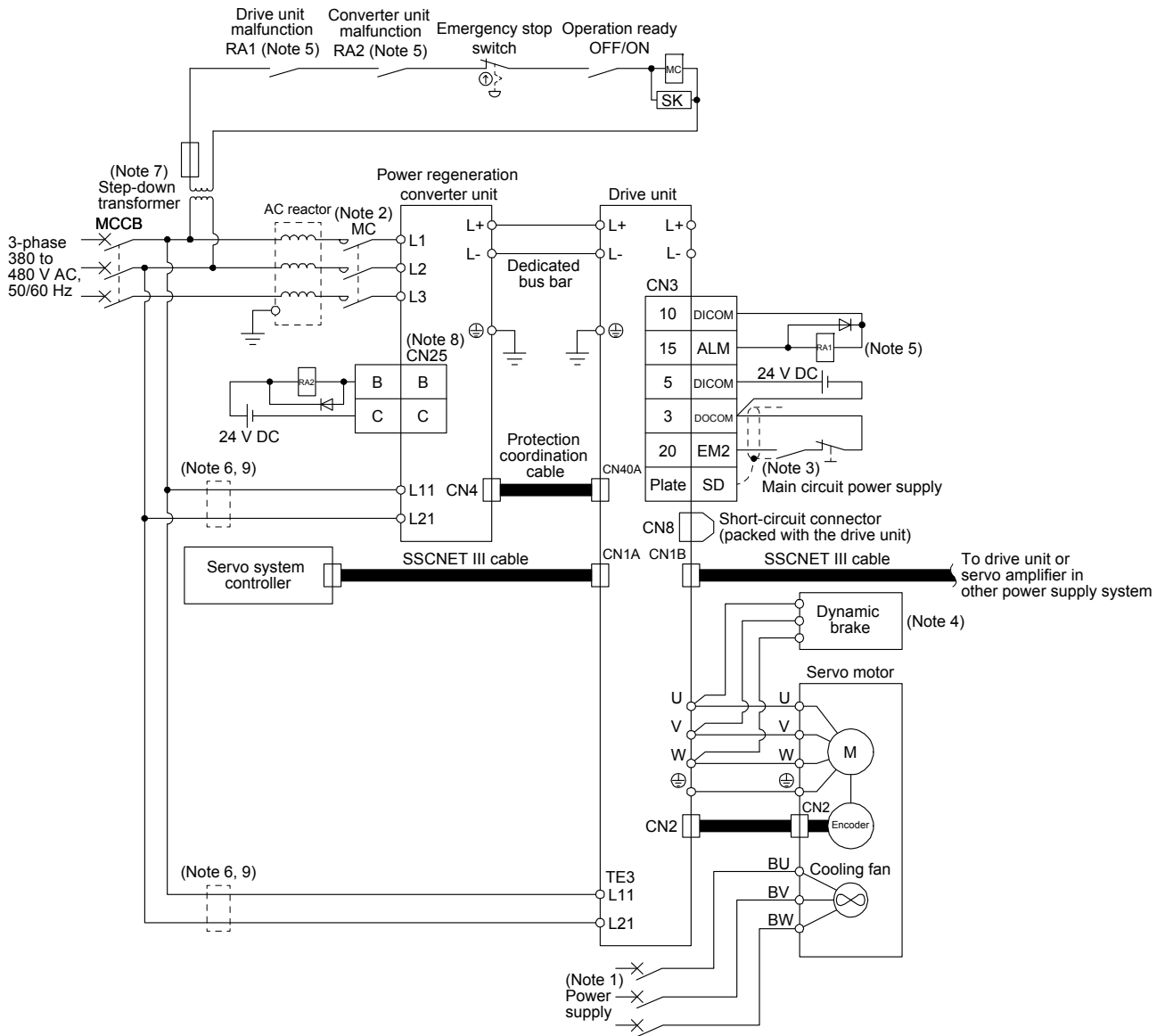

3. MR-CV_ POWER REGENERATION CONVERTER UNIT

- Note
1. For specifications of the cooling fan power supply, refer to "Servo Motor Instruction Manual (Vol. 3)". When using the same power supply for the main circuit and cooling fan for MR-CV_, do not supply power between the MR-CV_ and AC reactor or to the inductive load from the secondary side of the magnetic contactor.
 2. Use a magnetic contactor with an operation delay time (interval between current being applied to the coil until closure of contacts) of 80 ms or less. A bus voltage may drop, depending on the main circuit voltage and operation pattern, causing a dynamic brake deceleration during a forced stop deceleration.
 3. To prevent an unexpected restart of the drive unit, configure a circuit to turn off EM2 in the drive unit when the main circuit power is turned off.
 4. Use an external dynamic brake for this drive unit. Failure to do so will cause an accident because the servo motor does not stop immediately but coasts at an alarm occurrence for which the servo motor does not decelerate to stop. Ensure the safety in the entire equipment. For alarms for which the servo motor does not decelerate to stop, refer to chapter 6. For wiring of the external dynamic brake, refer to section 8.3. When using the external dynamic brake, assign DB (Dynamic brake interlock) to the CN3 connector pin with [Pr. PD07] to [Pr. PD09].
 5. Configure a sequence that will shut off the main circuit power when an alarm occurs.
 6. Install an overcurrent protection device (molded-case circuit breaker, fuse, or others) to protect the branch circuit. (Refer to section 8.5.)
 7. A step-down transformer is required when the coil voltage of the magnetic contactor is 200 V class.
 8. Connect to an error output (A/B/C) via a relay coil, etc.
 9. The control circuit power supply (L11/L21) can be connected by passing wiring. Refer to section 6.8 for the wire size and the selection of the overcurrent protection device.

3. MR-CV_ POWER REGENERATION CONVERTER UNIT

- (b) Connecting multiple drive units to one power regeneration converter unit
 1) When magnetic contactor drive output is enabled (factory setting)

POINT
● The power regeneration converter unit controls the magnetic contactor.
● Connect the power regeneration converter unit and the adjacent drive unit with MR-CUL06M protection coordination cable.
● When multiple drive units are connected to one power regeneration converter unit, use EM1 for the emergency stop of the drive unit, and stop the servo motor with the dynamic brake if an error occurs. Set [Pr. PA04] to "0000" to enable EM1.
● Set [Pr. PA02] to "4700" and [Pr. PF03] to "0100" for the drive unit to which the protection coordination cable is not connected.
● Be sure to simultaneously turn on and off the control circuit power supplies of the power regeneration converter unit and the drive unit.

a) 200 V class

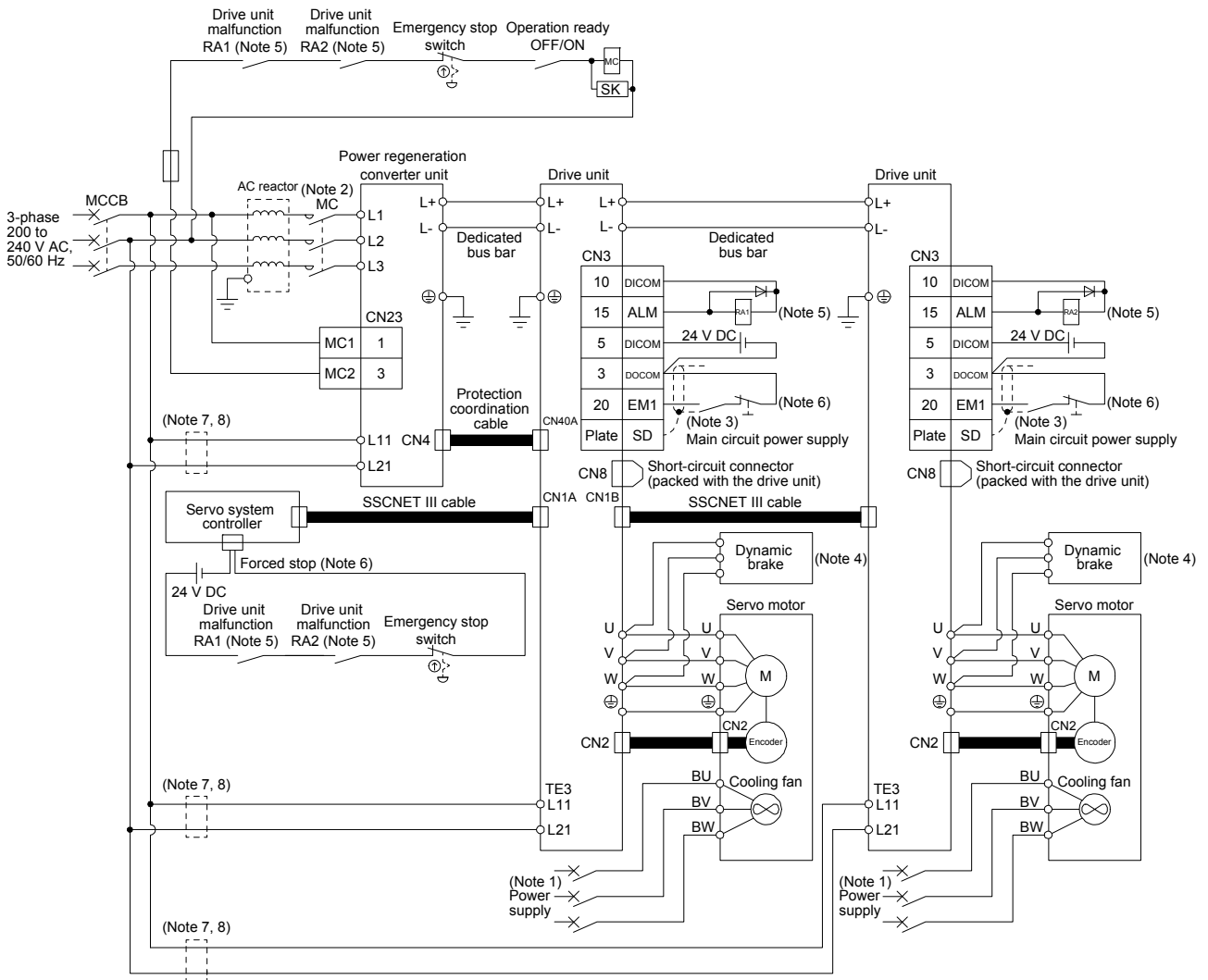

3. MR-CV_ POWER REGENERATION CONVERTER UNIT

- Note
1. For specifications of the cooling fan power supply, refer to "Servo Motor Instruction Manual (Vol. 3)". When using the same power supply for the main circuit and cooling fan for MR-CV_, do not supply power between the MR-CV_ and AC reactor or to the inductive load from the secondary side of the magnetic contactor.
 2. Use a magnetic contactor with an operation delay time (interval between current being applied to the coil until closure of contacts) of 80 ms or less. A bus voltage may drop, depending on the main circuit voltage and operation pattern, causing a dynamic brake deceleration during a forced stop deceleration.
 3. To prevent an unexpected restart of the drive unit, configure a circuit to turn off EM1 in the drive unit when the main circuit power is turned off.
 4. Use an external dynamic brake for this drive unit. Failure to do so will cause an accident because the servo motor does not stop immediately but coasts at an alarm occurrence for which the servo motor does not decelerate to stop. Ensure the safety in the entire equipment. For alarms for which the servo motor does not decelerate to stop, refer to chapter 6. For wiring of the external dynamic brake, refer to section 8.3. When using the external dynamic brake, assign DB (Dynamic brake interlock) to the CN3 connector pin with [Pr. PD07] to [Pr. PD09].
 5. When connecting multiple drive units, configure a sequence that will shut off the main circuit power if an alarm occurs even in one axis.
 6. Configure a sequence in which the servo system controller will stop all the drive units if an alarm occurs even in one drive unit.
 7. Install an overcurrent protection device (molded-case circuit breaker, fuse, or others) to protect the branch circuit. (Refer to section 8.5.)
 8. The control circuit power supply (L11/L21) can be connected by passing wiring. Refer to section 6.8 for the wire size and the selection of the overcurrent protection device.

3. MR-CV_ POWER REGENERATION CONVERTER UNIT

b) 400 V class

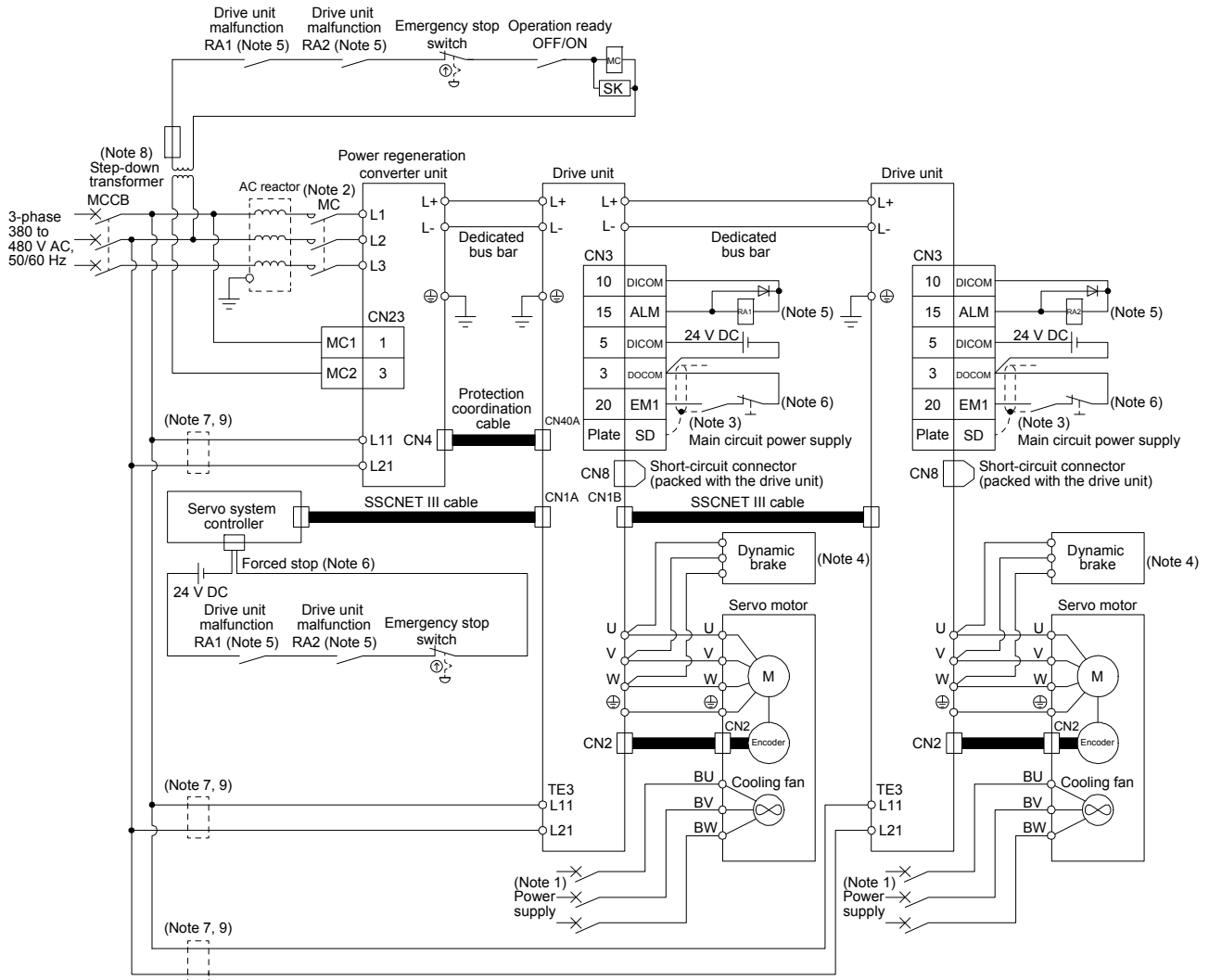

- Note 1. For specifications of the cooling fan power supply, refer to "Servo Motor Instruction Manual (Vol. 3)". When using the same power supply for the main circuit and cooling fan for MR-CV_, do not supply power between the MR-CV_ and AC reactor or to the inductive load from the secondary side of the magnetic contactor.
- Note 2. Use a magnetic contactor with an operation delay time (interval between current being applied to the coil until closure of contacts) of 80 ms or less. A bus voltage may drop, depending on the main circuit voltage and operation pattern, causing a dynamic brake deceleration during a forced stop deceleration.
- Note 3. To prevent an unexpected restart of the drive unit, configure a circuit to turn off EM1 in the drive unit when the main circuit power is turned off.
- Note 4. Use an external dynamic brake for this drive unit. Failure to do so will cause an accident because the servo motor does not stop immediately but coasts at an alarm occurrence for which the servo motor does not decelerate to stop. Ensure the safety in the entire equipment. For alarms for which the servo motor does not decelerate to stop, refer to chapter 6. For wiring of the external dynamic brake, refer to section 8.3. When using the external dynamic brake, assign DB (Dynamic brake interlock) to the CN3 connector pin with [Pr. PD07] to [Pr. PD09].
- Note 5. When connecting multiple drive units, configure a sequence that will shut off the main circuit power if an alarm occurs even in one axis.
- Note 6. Configure a sequence in which the servo system controller will stop all the drive units if an alarm occurs even in one drive unit.
- Note 7. Install an overcurrent protection device (molded-case circuit breaker, fuse, or others) to protect the branch circuit. (Refer to section 8.5.)
- Note 8. A step-down transformer is required when the coil voltage of the magnetic contactor is 200 V class.
- Note 9. The control circuit power supply (L11/L21) can be connected by passing wiring. Refer to section 6.8 for the wire size and the selection of the overcurrent protection device.

3. MR-CV_ POWER REGENERATION CONVERTER UNIT

- 2) When magnetic contactor drive output is disabled
 a) 200 V class

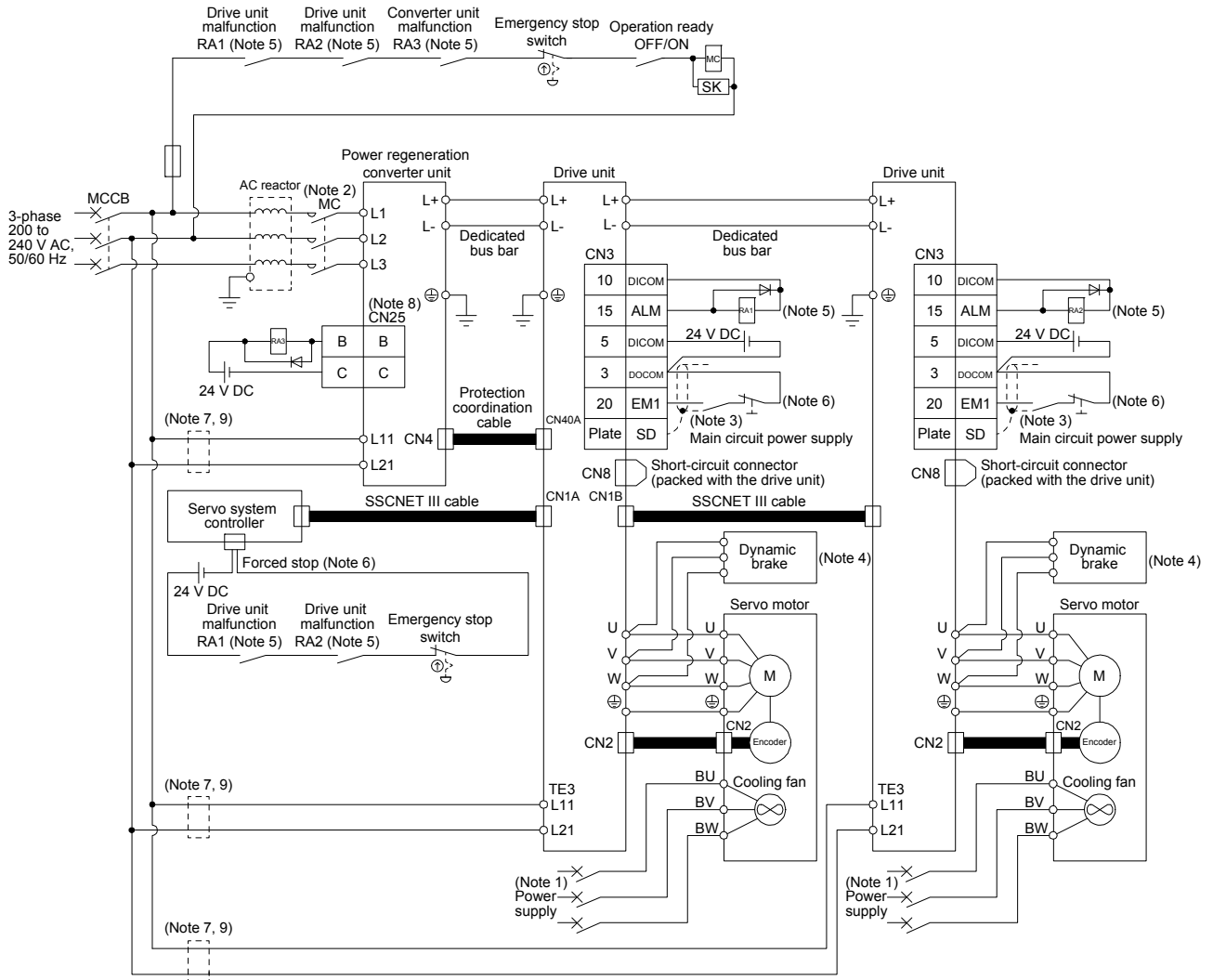

3. MR-CV_ POWER REGENERATION CONVERTER UNIT

- Note
1. For specifications of the cooling fan power supply, refer to "Servo Motor Instruction Manual (Vol. 3)". When using the same power supply for the main circuit and cooling fan for MR-CV_, do not supply power between the MR-CV_ and AC reactor or to the inductive load from the secondary side of the magnetic contactor.
 2. Use a magnetic contactor with an operation delay time (interval between current being applied to the coil until closure of contacts) of 80 ms or less. A bus voltage may drop, depending on the main circuit voltage and operation pattern, causing a dynamic brake deceleration during a forced stop deceleration.
 3. To prevent an unexpected restart of the drive unit, configure a circuit to turn off EM1 in the drive unit when the main circuit power is turned off.
 4. Use an external dynamic brake for this drive unit. Failure to do so will cause an accident because the servo motor does not stop immediately but coasts at an alarm occurrence for which the servo motor does not decelerate to stop. Ensure the safety in the entire equipment. For alarms for which the servo motor does not decelerate to stop, refer to chapter 6. For wiring of the external dynamic brake, refer to section 8.3. When using the external dynamic brake, assign DB (Dynamic brake interlock) to the CN3 connector pin with [Pr. PD07] to [Pr. PD09].
 5. When connecting multiple drive units, configure a sequence that will shut off the main circuit power if an alarm occurs even in one axis.
 6. Configure a sequence in which the servo system controller will stop all the drive units if an alarm occurs even in one drive unit.
 7. Install an overcurrent protection device (molded-case circuit breaker, fuse, or others) to protect the branch circuit. (Refer to section 8.5.)
 8. Connect to an error output (A/B/C) via a relay coil, etc.
 9. The control circuit power supply (L11/L21) can be connected by passing wiring. Refer to section 6.8 for the wire size and the selection of the overcurrent protection device.

3. MR-CV_ POWER REGENERATION CONVERTER UNIT

b) 400 V class

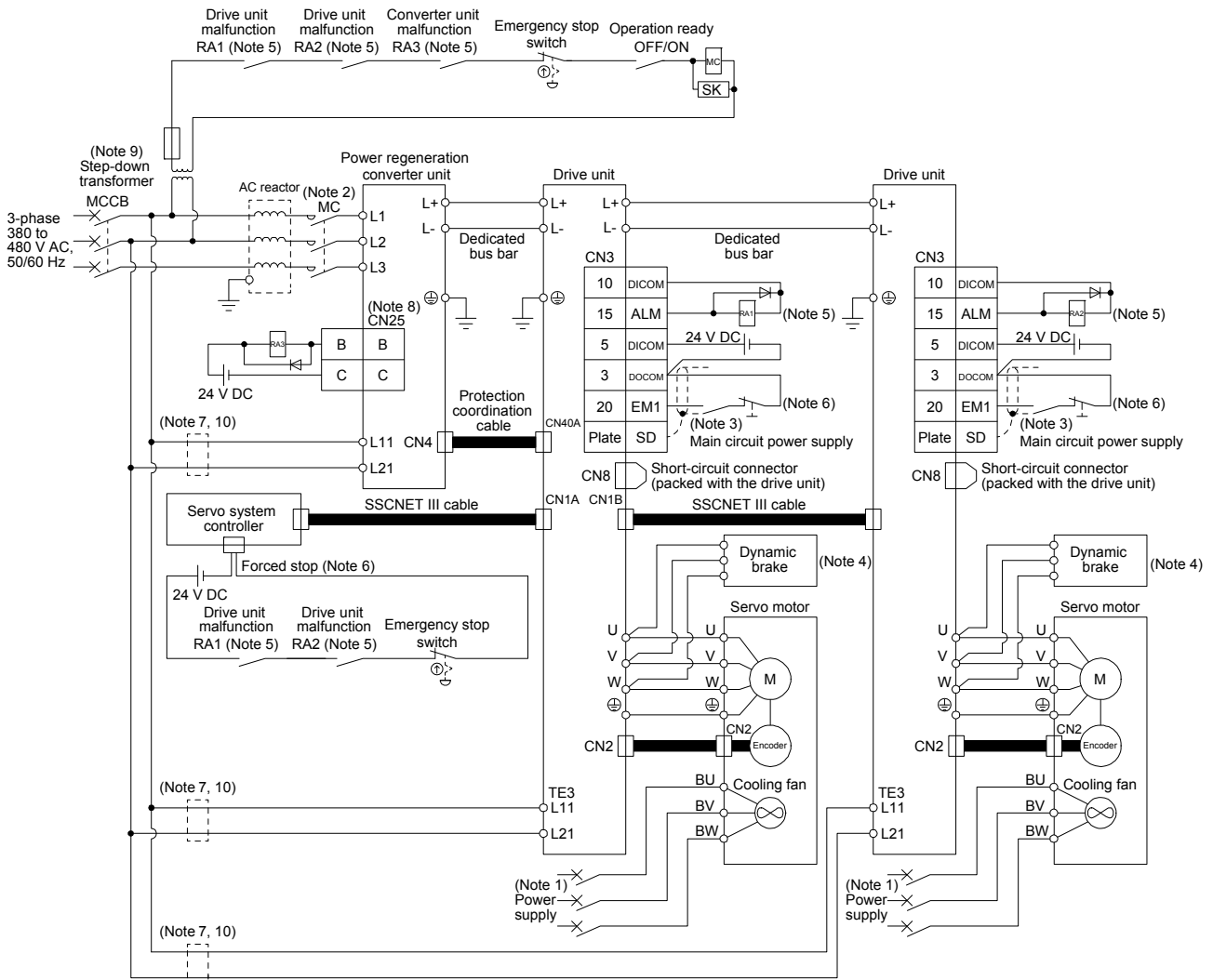

- Note 1. For specifications of the cooling fan power supply, refer to "Servo Motor Instruction Manual (Vol. 3)". When using the same power supply for the main circuit and cooling fan for MR-CV_, do not supply power between the MR-CV_ and AC reactor or to the inductive load from the secondary side of the magnetic contactor.
- Note 2. Use a magnetic contactor with an operation delay time (interval between current being applied to the coil until closure of contacts) of 80 ms or less. A bus voltage may drop, depending on the main circuit voltage and operation pattern, causing a dynamic brake deceleration during a forced stop deceleration.
- Note 3. To prevent an unexpected restart of the drive unit, configure a circuit to turn off EM1 in the drive unit when the main circuit power is turned off.
- Note 4. Use an external dynamic brake for this drive unit. Failure to do so will cause an accident because the servo motor does not stop immediately but coasts at an alarm occurrence for which the servo motor does not decelerate to stop. Ensure the safety in the entire equipment. For alarms for which the servo motor does not decelerate to stop, refer to chapter 6. For wiring of the external dynamic brake, refer to section 8.3. When using the external dynamic brake, assign DB (Dynamic brake interlock) to the CN3 connector pin with [Pr. PD07] to [Pr. PD09].
- Note 5. When connecting multiple drive units, configure a sequence that will shut off the main circuit power if an alarm occurs even in one axis.
- Note 6. Configure a sequence in which the servo system controller will stop all the drive units if an alarm occurs even in one drive unit.
- Note 7. Install an overcurrent protection device (molded-case circuit breaker, fuse, or others) to protect the branch circuit. (Refer to section 8.5.)
- Note 8. Connect to an error output (A/B/C) via a relay coil, etc.
- Note 9. A step-down transformer is required when the coil voltage of the magnetic contactor is 200 V class.
- Note 10. The control circuit power supply (L11/L21) can be connected by passing wiring. Refer to section 6.8 for the wire size and the selection of the overcurrent protection device.

3. MR-CV_ POWER REGENERATION CONVERTER UNIT

- (c) Connecting multiple drive units and servo amplifiers to one power regeneration converter unit
 1) When magnetic contactor drive output is enabled (factory setting)

POINT
<ul style="list-style-type: none"> ● The power regeneration converter unit controls the magnetic contactor. ● Connect the power regeneration converter unit and the adjacent drive unit with MR-CUL06M protection coordination cable. ● When multiple drive units and servo amplifiers are connected to one power regeneration converter unit, use EM1 for the emergency stop of the drive units and servo amplifiers, and stop the servo motors with the dynamic brake if an error occurs. Set [Pr. PA04] to "0000" to enable EM1. ● Set [Pr. PA02] to "4700" and [Pr. PF03] to "0100" for the drive unit to which the protection coordination cable is not connected. ● Be sure to simultaneously turn on and off the control circuit power supplies of the power regeneration converter unit, drive unit, and servo amplifier.

a) 200 V class

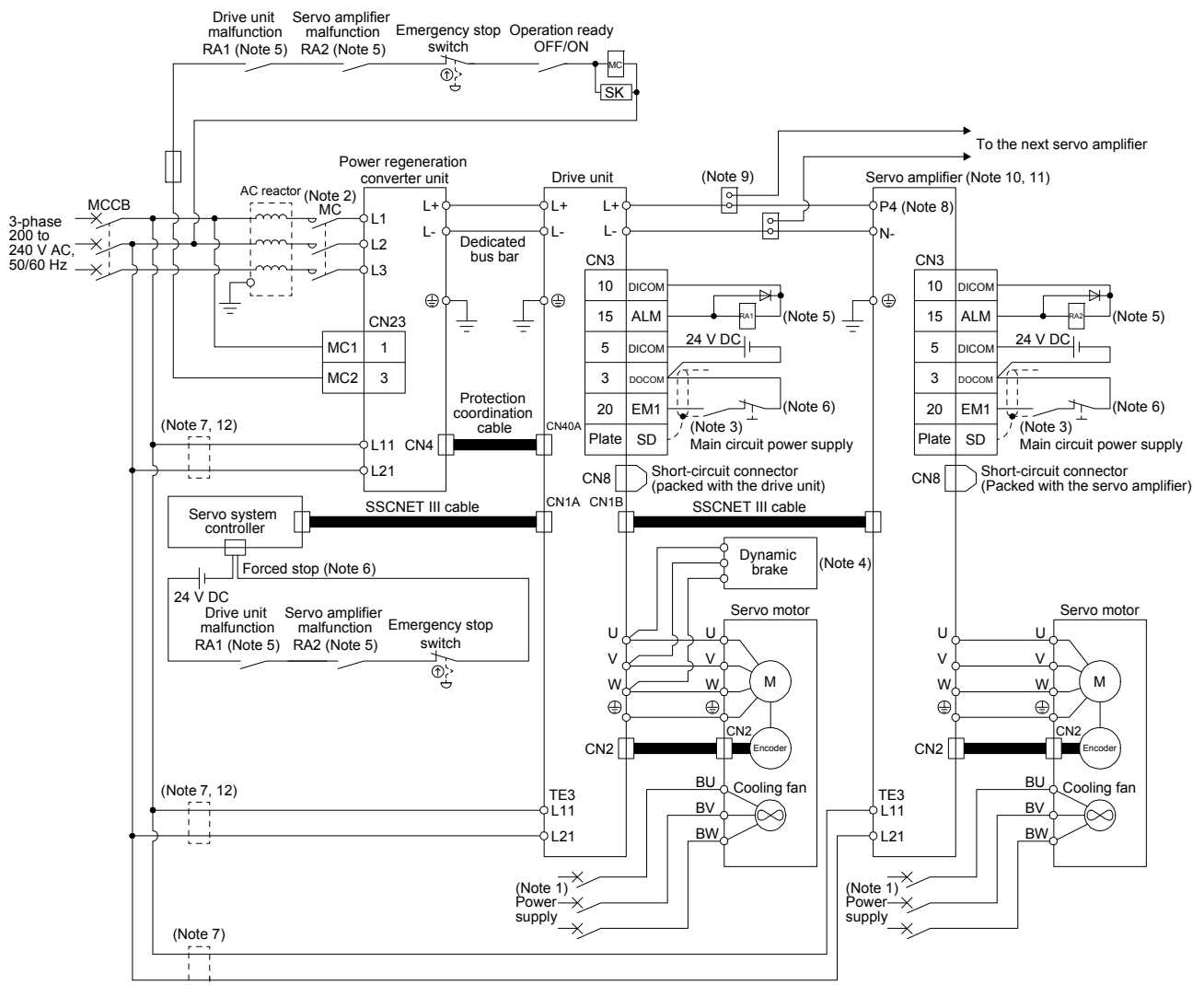

3. MR-CV_ POWER REGENERATION CONVERTER UNIT

- Note
1. For specifications of the cooling fan power supply, refer to "Servo Motor Instruction Manual (Vol. 3)". When using the same power supply for the main circuit and cooling fan for MR-CV_, do not supply power between the MR-CV_ and AC reactor or to the inductive load from the secondary side of the magnetic contactor.
 2. Use a magnetic contactor with an operation delay time (interval between current being applied to the coil until closure of contacts) of 80 ms or less. A bus voltage may drop, depending on the main circuit voltage and operation pattern, causing a dynamic brake deceleration during a forced stop deceleration.
 3. To prevent an unexpected restart of the drive unit and servo amplifier, configure a circuit to turn off EM1 in the drive unit and servo amplifier when the main circuit power is turned off.
 4. Use an external dynamic brake for this drive unit. Failure to do so will cause an accident because the servo motor does not stop immediately but coasts at an alarm occurrence for which the servo motor does not decelerate to stop. Ensure the safety in the entire equipment. For alarms for which the servo motor does not decelerate to stop, refer to chapter 6. For wiring of the external dynamic brake, refer to section 8.3. When using the external dynamic brake, assign DB (Dynamic brake interlock) to the CN3 connector pin with [Pr. PD07] to [Pr. PD09].
 5. When connecting multiple drive units and servo amplifiers, configure a sequence that will shut off the main circuit power if an alarm occurs even in one axis.
 6. Configure a sequence in which the servo system controller will stop all the drive units (servo amplifiers) if an alarm occurs even in one drive unit (servo amplifier).
 7. Install an overcurrent protection device (molded-case circuit breaker, fuse, or others) to protect the branch circuit. (Refer to section 8.5.)
 8. For the terminal block and connector, refer to "MR-J4-_B_(-RJ) Servo Amplifier Instruction Manual".
 9. Connect the main circuit power supply of the servo amplifier via a terminal block, and keep the wiring length of 1.5 m or longer.
 10. Be sure to disconnect between P3 and P4.
 11. When using the servo amplifier of 7 kW or less, make sure to connect the built-in regenerative resistor. (factory-wired) (5 kW or less: P+ and D, 7 kW or less: P+ and C)
 12. The control circuit power supply (L11/L21) can be connected by passing wiring. Refer to section 6.8 for the wire size and the selection of the overcurrent protection device.

3. MR-CV_ POWER REGENERATION CONVERTER UNIT

b) 400 V class

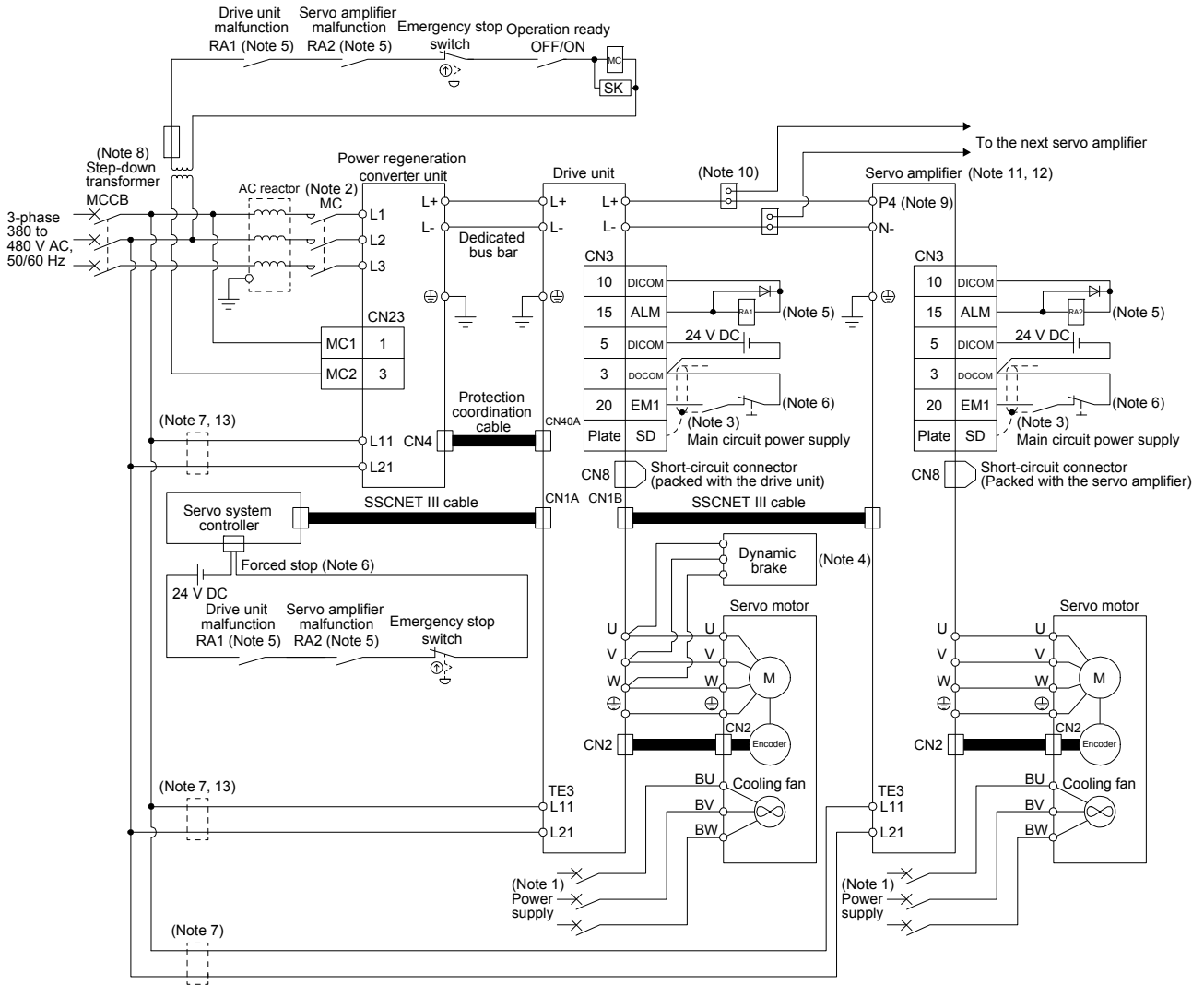

3. MR-CV_ POWER REGENERATION CONVERTER UNIT

- Note
1. For specifications of the cooling fan power supply, refer to "Servo Motor Instruction Manual (Vol. 3)". When using the same power supply for the main circuit and cooling fan for MR-CV_, do not supply power between the MR-CV_ and AC reactor or to the inductive load from the secondary side of the magnetic contactor.
 2. Use a magnetic contactor with an operation delay time (interval between current being applied to the coil until closure of contacts) of 80 ms or less. A bus voltage may drop, depending on the main circuit voltage and operation pattern, causing a dynamic brake deceleration during a forced stop deceleration.
 3. To prevent an unexpected restart of the drive unit and servo amplifier, configure a circuit to turn off EM1 in the drive unit and servo amplifier when the main circuit power is turned off.
 4. Use an external dynamic brake for this drive unit. Failure to do so will cause an accident because the servo motor does not stop immediately but coasts at an alarm occurrence for which the servo motor does not decelerate to stop. Ensure the safety in the entire equipment. For alarms for which the servo motor does not decelerate to stop, refer to chapter 6. For wiring of the external dynamic brake, refer to section 8.3. When using the external dynamic brake, assign DB (Dynamic brake interlock) to the CN3 connector pin with [Pr. PD07] to [Pr. PD09].
 5. When connecting multiple drive units and servo amplifiers, configure a sequence that will shut off the main circuit power if an alarm occurs even in one axis.
 6. Configure a sequence in which the servo system controller will stop all the drive units (servo amplifiers) if an alarm occurs even in one drive unit (servo amplifier).
 7. Install an overcurrent protection device (molded-case circuit breaker, fuse, or others) to protect the branch circuit. (Refer to section 8.5.)
 8. A step-down transformer is required when the coil voltage of the magnetic contactor is 200 V class.
 9. For the terminal block and connector, refer to "MR-J4-_B_(-RJ) Servo Amplifier Instruction Manual".
 10. Connect the main circuit power supply of the servo amplifier via a terminal block, and keep the wiring length of 1.5 m or longer.
 11. Be sure to disconnect between P3 and P4.
 12. When using the servo amplifier of 7 kW or less, make sure to connect the built-in regenerative resistor. (factory-wired) (5 kW or less: P+ and D, 7 kW or less: P+ and C)
 13. The control circuit power supply (L11/L21) can be connected by passing wiring. Refer to section 6.8 for the wire size and the selection of the overcurrent protection device.

3. MR-CV_ POWER REGENERATION CONVERTER UNIT

- 2) When magnetic contactor drive output is disabled
 - a) 200 V class

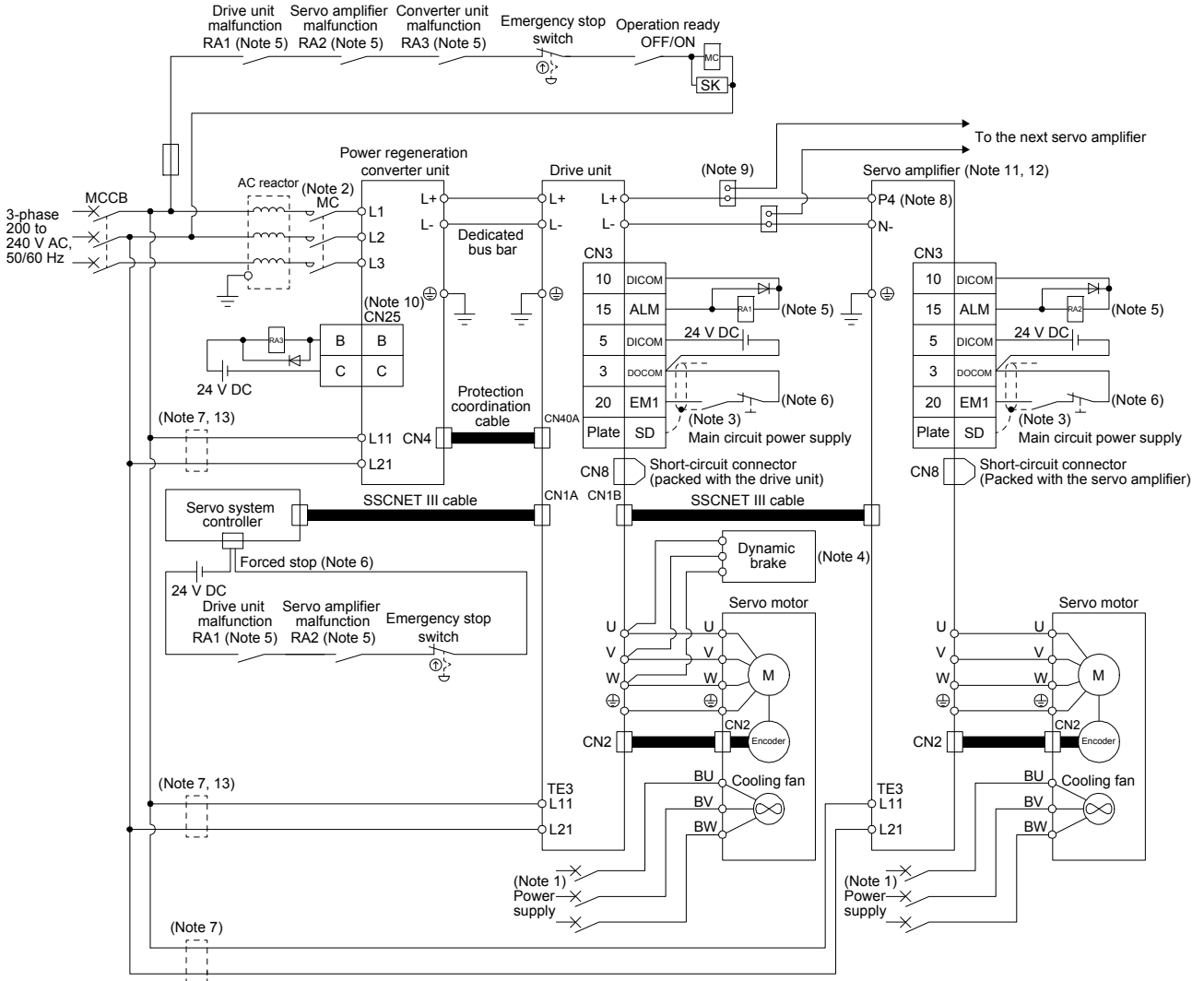

3. MR-CV_ POWER REGENERATION CONVERTER UNIT

- Note
1. For specifications of the cooling fan power supply, refer to "Servo Motor Instruction Manual (Vol. 3)". When using the same power supply for the main circuit and cooling fan for MR-CV_, do not supply power between the MR-CV_ and AC reactor or to the inductive load from the secondary side of the magnetic contactor.
 2. Use a magnetic contactor with an operation delay time (interval between current being applied to the coil until closure of contacts) of 80 ms or less. A bus voltage may drop, depending on the main circuit voltage and operation pattern, causing a dynamic brake deceleration during a forced stop deceleration.
 3. To prevent an unexpected restart of the drive unit and servo amplifier, configure a circuit to turn off EM1 in the drive unit and servo amplifier when the main circuit power is turned off.
 4. Use an external dynamic brake for this drive unit. Failure to do so will cause an accident because the servo motor does not stop immediately but coasts at an alarm occurrence for which the servo motor does not decelerate to stop. Ensure the safety in the entire equipment. For alarms for which the servo motor does not decelerate to stop, refer to chapter 6. For wiring of the external dynamic brake, refer to section 8.3. When using the external dynamic brake, assign DB (Dynamic brake interlock) to the CN3 connector pin with [Pr. PD07] to [Pr. PD09].
 5. When connecting multiple drive units and servo amplifiers, configure a sequence that will shut off the main circuit power if an alarm occurs even in one axis.
 6. Configure a sequence in which the servo system controller will stop all the drive units (servo amplifiers) if an alarm occurs even in one drive unit (servo amplifier).
 7. Install an overcurrent protection device (molded-case circuit breaker, fuse, or others) to protect the branch circuit. (Refer to section 8.5.)
 8. For the terminal block and connector, refer to "MR-J4-_B_(-RJ) Servo Amplifier Instruction Manual".
 9. Connect the main circuit power supply of the servo amplifier via a terminal block, and keep the wiring length of 1.5 m or longer.
 10. Connect to an error output (A/B/C) via a relay coil, etc.
 11. Be sure to disconnect between P3 and P4.
 12. When using the servo amplifier of 7 kW or less, make sure to connect the built-in regenerative resistor. (factory-wired) (5 kW or less: P+ and D, 7 kW or less: P+ and C)
 13. The control circuit power supply (L11/L21) can be connected by passing wiring. Refer to section 6.8 for the wire size and the selection of the overcurrent protection device.

3. MR-CV_ POWER REGENERATION CONVERTER UNIT

b) 400 V class

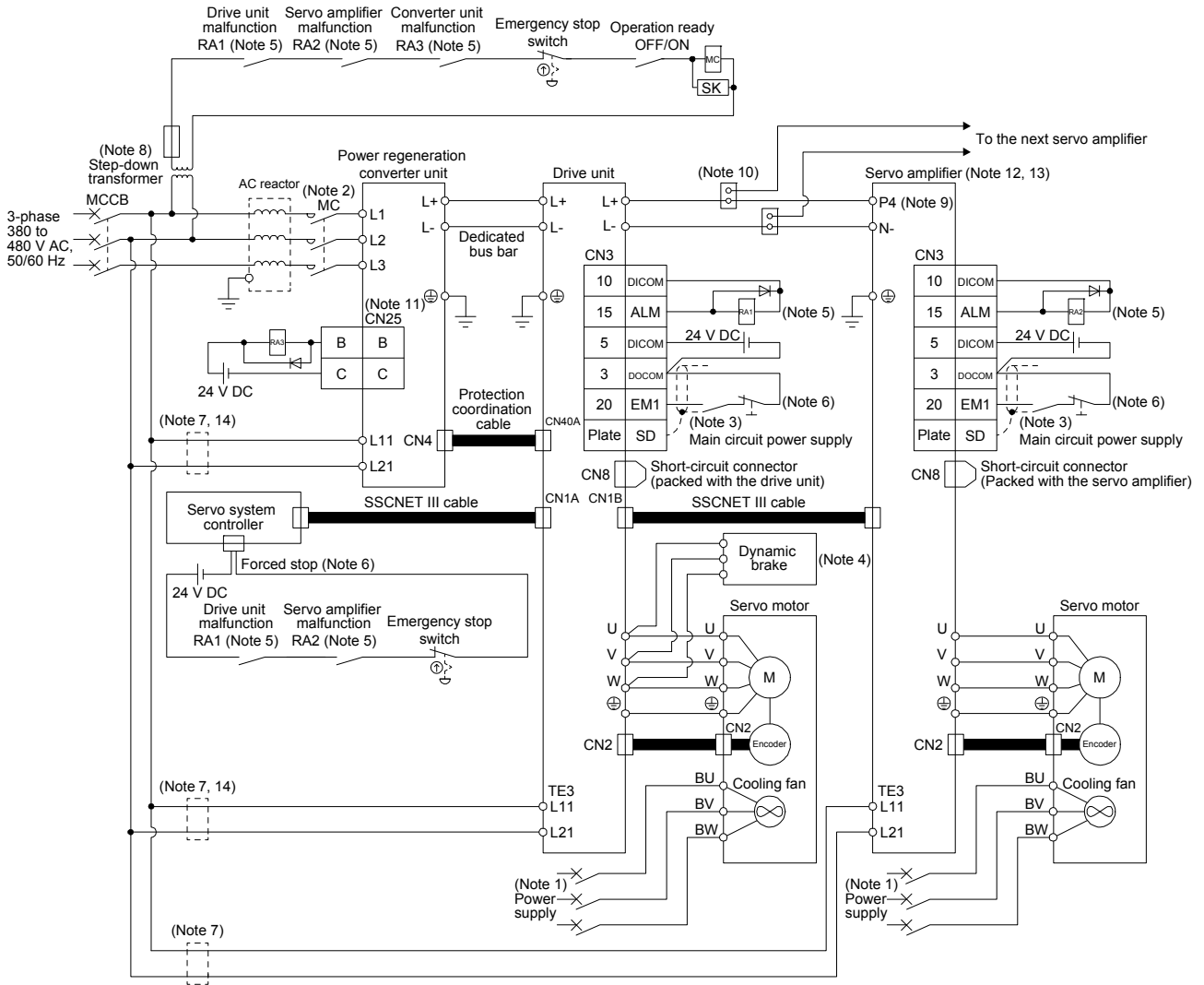

3. MR-CV_ POWER REGENERATION CONVERTER UNIT

- Note
1. For specifications of the cooling fan power supply, refer to "Servo Motor Instruction Manual (Vol. 3)". When using the same power supply for the main circuit and cooling fan for MR-CV_, do not supply power between the MR-CV_ and AC reactor or to the inductive load from the secondary side of the magnetic contactor.
 2. Use a magnetic contactor with an operation delay time (interval between current being applied to the coil until closure of contacts) of 80 ms or less. A bus voltage may drop, depending on the main circuit voltage and operation pattern, causing a dynamic brake deceleration during a forced stop deceleration.
 3. To prevent an unexpected restart of the drive unit and servo amplifier, configure a circuit to turn off EM1 in the drive unit and servo amplifier when the main circuit power is turned off.
 4. Use an external dynamic brake for this drive unit. Failure to do so will cause an accident because the servo motor does not stop immediately but coasts at an alarm occurrence for which the servo motor does not decelerate to stop. Ensure the safety in the entire equipment. For alarms for which the servo motor does not decelerate to stop, refer to chapter 6. For wiring of the external dynamic brake, refer to section 8.3. When using the external dynamic brake, assign DB (Dynamic brake interlock) to the CN3 connector pin with [Pr. PD07] to [Pr. PD09].
 5. When connecting multiple drive units and servo amplifiers, configure a sequence that will shut off the main circuit power if an alarm occurs even in one axis.
 6. Configure a sequence in which the servo system controller will stop all the drive units (servo amplifiers) if an alarm occurs even in one drive unit (servo amplifier).
 7. Install an overcurrent protection device (molded-case circuit breaker, fuse, or others) to protect the branch circuit. (Refer to section 8.5.)
 8. A step-down transformer is required when the coil voltage of the magnetic contactor is 200 V class.
 9. For the terminal block and connector, refer to "MR-J4-_B_(-RJ) Servo Amplifier Instruction Manual".
 10. Connect the main circuit power supply of the servo amplifier via a terminal block, and keep the wiring length of 1.5 m or longer.
 11. Connect to an error output (A/B/C) via a relay coil, etc.
 12. Be sure to disconnect between P3 and P4.
 13. When using the servo amplifier of 7 kW or less, make sure to connect the built-in regenerative resistor. (factory-wired) (5 kW or less: P+ and D, 7 kW or less: P+ and C)
 14. The control circuit power supply (L11/L21) can be connected by passing wiring. Refer to section 6.8 for the wire size and the selection of the overcurrent protection device.

3. MR-CV_ POWER REGENERATION CONVERTER UNIT

(3) How to use the bus bars

POINT
<ul style="list-style-type: none"> ● The bus bars attached to the drive unit are only for the connection with the MR-CR_ resistance regeneration converter unit. The bus bars attached to the drive unit of 30 kW or more may not be usable. Refer to section 8.12 for the combinations of the bus bars. ● When mounting a drive unit in the right side of MR-J4-DU900B(4)(-RJ) or MR-J4-DU11KB(4)(-RJ), place the bus bars on top of each other on the TE2 terminal block of MR-J4-DU900B(4)(-RJ) or MR-J4-DU11KB(4)(-RJ), and screw them together. ● When the total number of MR-J4-DU900B(4)(-RJ) and MR-J4-DU11KB(4)(-RJ) drive units connected to the power regeneration convert unit is even, there is a gap of bar thickness between the bus bar and TE2 terminal block of the final drive unit. Place adjustment bars in the gap and screw them together. Please purchase the adjustment bars separately. (Refer to section 8.12.2.)

Connect L+ and L- of the power regeneration converter unit and those of drive unit as follows with the dedicated bus bars. The units are shown with the terminal cover open.

When connecting the multiple drive units to one power regeneration converter unit, mount the drive units in descending order of capacity, from the right side of the power regeneration converter unit.

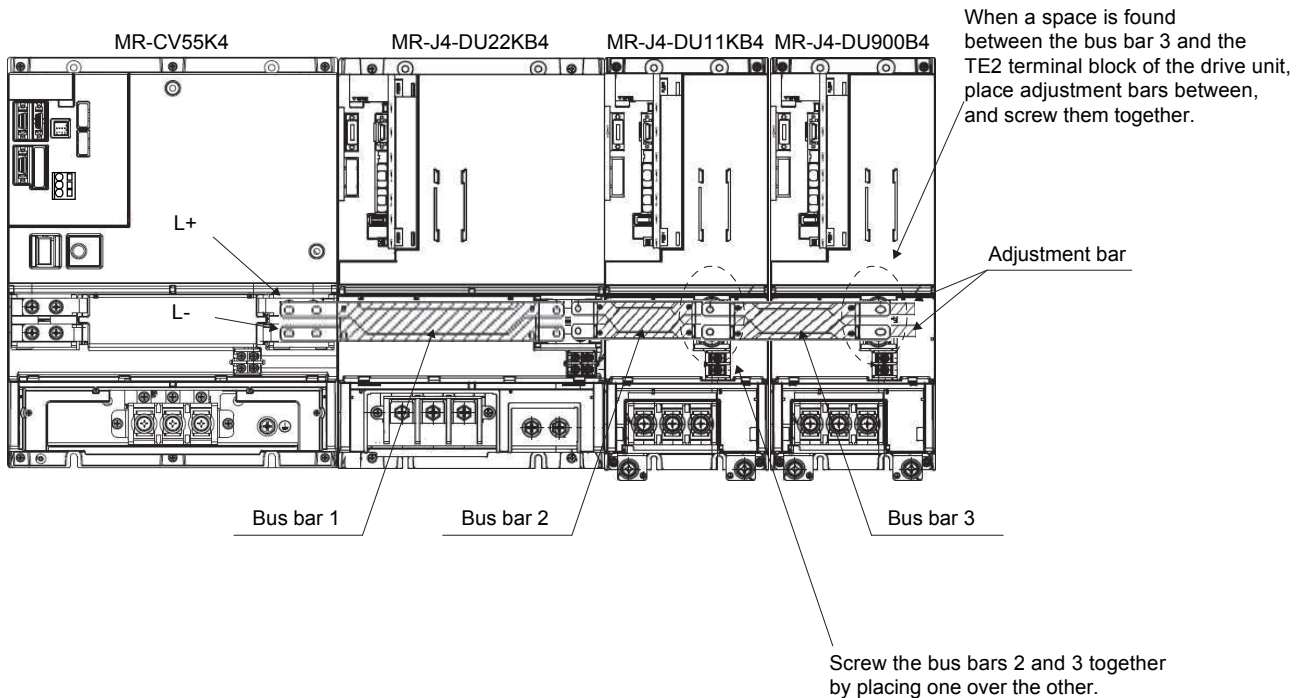

3. MR-CV_ POWER REGENERATION CONVERTER UNIT

3.3.2 Explanation of power supply system

(1) Signal explanations

POINT
● For the location of the terminal block, refer to chapter 7 DIMENSIONS.

Connection target (application)	Symbol	Terminal block	Description	
			MR-CV11K to MR-CV55K	MR-CV11K4 to MR-CV75K4
Main circuit power supply	L1/L2/L3	TE1	Supply 3-phase 200 V AC to 240 V AC, 50 Hz/60 Hz power to L1, L2, and L3.	Supply 3-phase 380 V AC to 480 V AC, 50 Hz/60 Hz power to L1, L2, and L3.
Control circuit power supply	L11/L21	TE3	Supply 1-phase 200 V AC to 240 V AC, 50 Hz/60 Hz power to L11 and L21.	Supply 1-phase 380 V AC to 480 V AC, 50 Hz/60 Hz power to L11 and L21.
Drive unit	L+/L-	TE2	Connect the L+ and L- of the drive unit to these terminals. Use bus bars for the connection.	
Protective earth (PE)	⊕	PE	Connect this terminal to the protective earth (PE) of the cabinet.	

(2) Power-on sequence

(a) Power-on procedure

- 1) Be sure to use a magnetic contactor for the main circuit power supply wiring (L1/L2/L3) as shown in above section 3.3.1 (2). Configure a circuit to switch off the magnetic contactor by an external sequence as soon as an alarm occurs.
- 2) Turn on the control circuit power supplies (L11/L21) of the power regeneration converter unit and drive unit simultaneously with or before the main circuit power supply. A warning appears on the display if the main circuit power supply is not turned on. When it is turned on, the warning disappears, and the operation starts normally.

3. MR-CV_ POWER REGENERATION CONVERTER UNIT

(b) Timing chart

1) Connecting one drive unit to one power regeneration converter unit

a) When magnetic contactor drive output is enabled and the status remains at ready-on
The main circuit power does not shut off with servo-off.

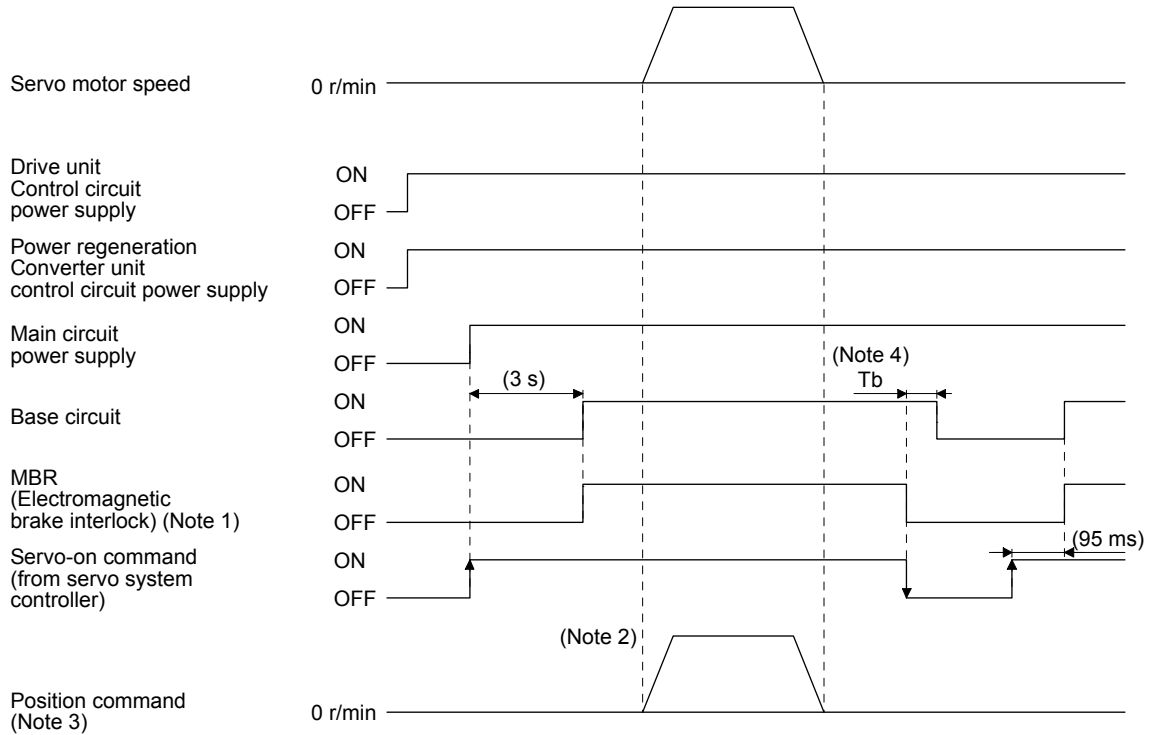

- Note 1. When an electromagnetic brake is installed externally, configure a sequence which operates the electromagnetic brake with MBR as follows.
ON: Electromagnetic brake is not activated.
OFF: Electromagnetic brake is activated.
2. Give a position command after the external electromagnetic brake is released.
3. This is in position control mode.
4. In [Pr. PC02 Electromagnetic brake sequence output], set a delay time (T_b) from MBR off to base circuit shut-off at servo-off.

3. MR-CV_ POWER REGENERATION CONVERTER UNIT

- b) When magnetic contactor drive output is enabled and the status returns to ready-off
 The magnetic contactor of the converter unit turns off with ready-off, and the main circuit power supply shuts off.

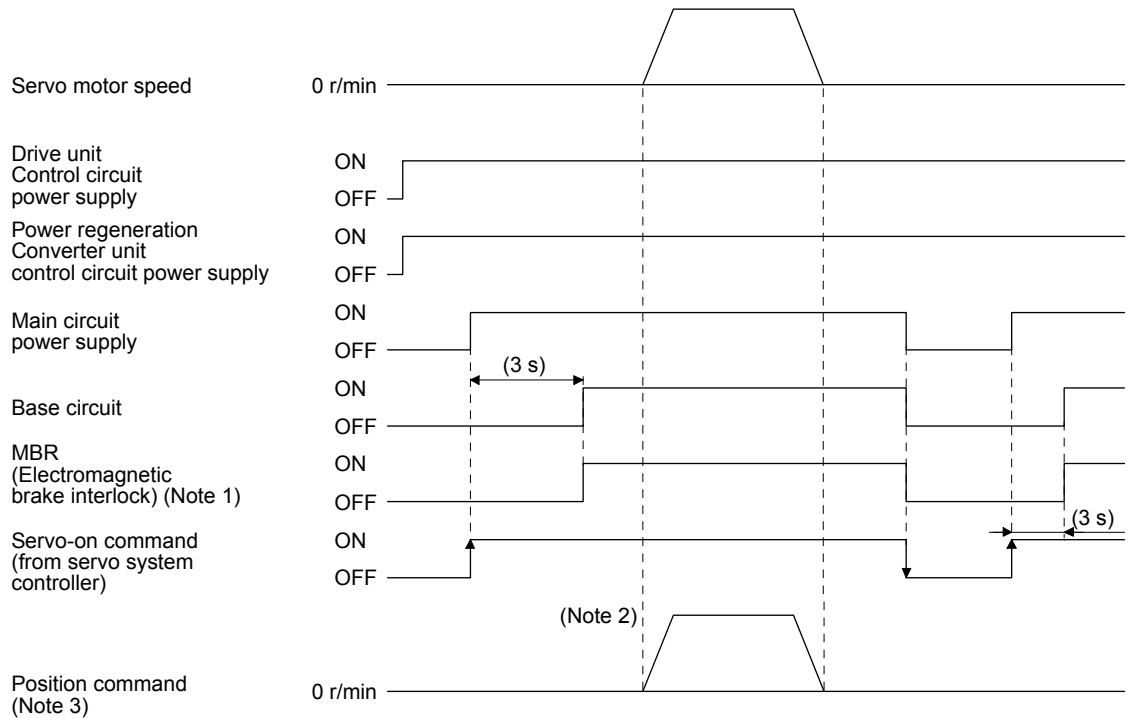

- Note 1. When an electromagnetic brake is installed externally, configure a sequence which operates the electromagnetic brake with MBR as follows.
 ON: Electromagnetic brake is not activated.
 OFF: Electromagnetic brake is activated.
2. Give a position command after the external electromagnetic brake is released.
3. This is in position control mode.

3. MR-CV_ POWER REGENERATION CONVERTER UNIT

c) When magnetic contactor drive output is disabled

When an alarm occurs, turn off the magnetic contactor using the external sequence, and shut off the main circuit power supply.

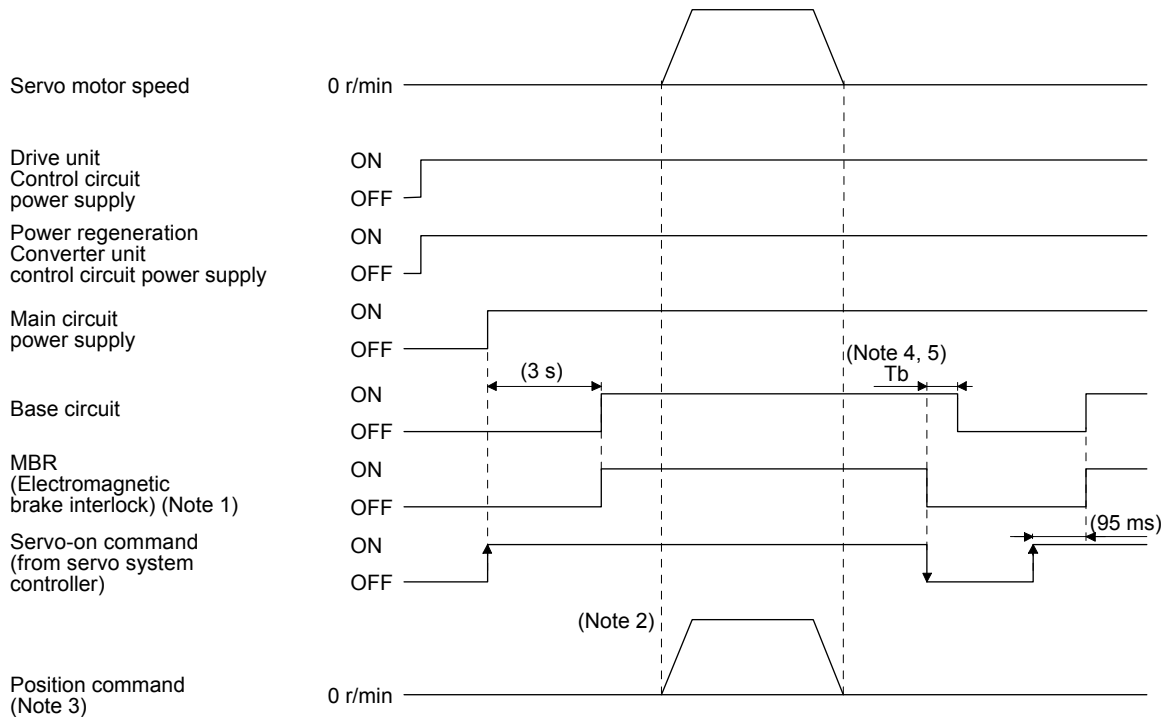

- Note 1. When an electromagnetic brake is installed externally, configure a sequence which operates the electromagnetic brake with MBR as follows.
 ON: Electromagnetic brake is not activated.
 OFF: Electromagnetic brake is activated.
2. Give a position command after the external electromagnetic brake is released.
3. This is in position control mode.
4. In [Pr. PC02 Electromagnetic brake sequence output], set a delay time (T_b) from MBR off to base circuit shut-off at servo-off.
5. The base circuit remains ready-on status at servo-off. When the status is ready-off, the base circuit and the servo-on command turn off at the same time. ($T_b = 0$)

3. MR-CV_ POWER REGENERATION CONVERTER UNIT

- 2) Connecting multiple drive units and servo amplifiers to one power regeneration converter unit
 a) When magnetic contactor drive output is enabled and the status remains at ready-on

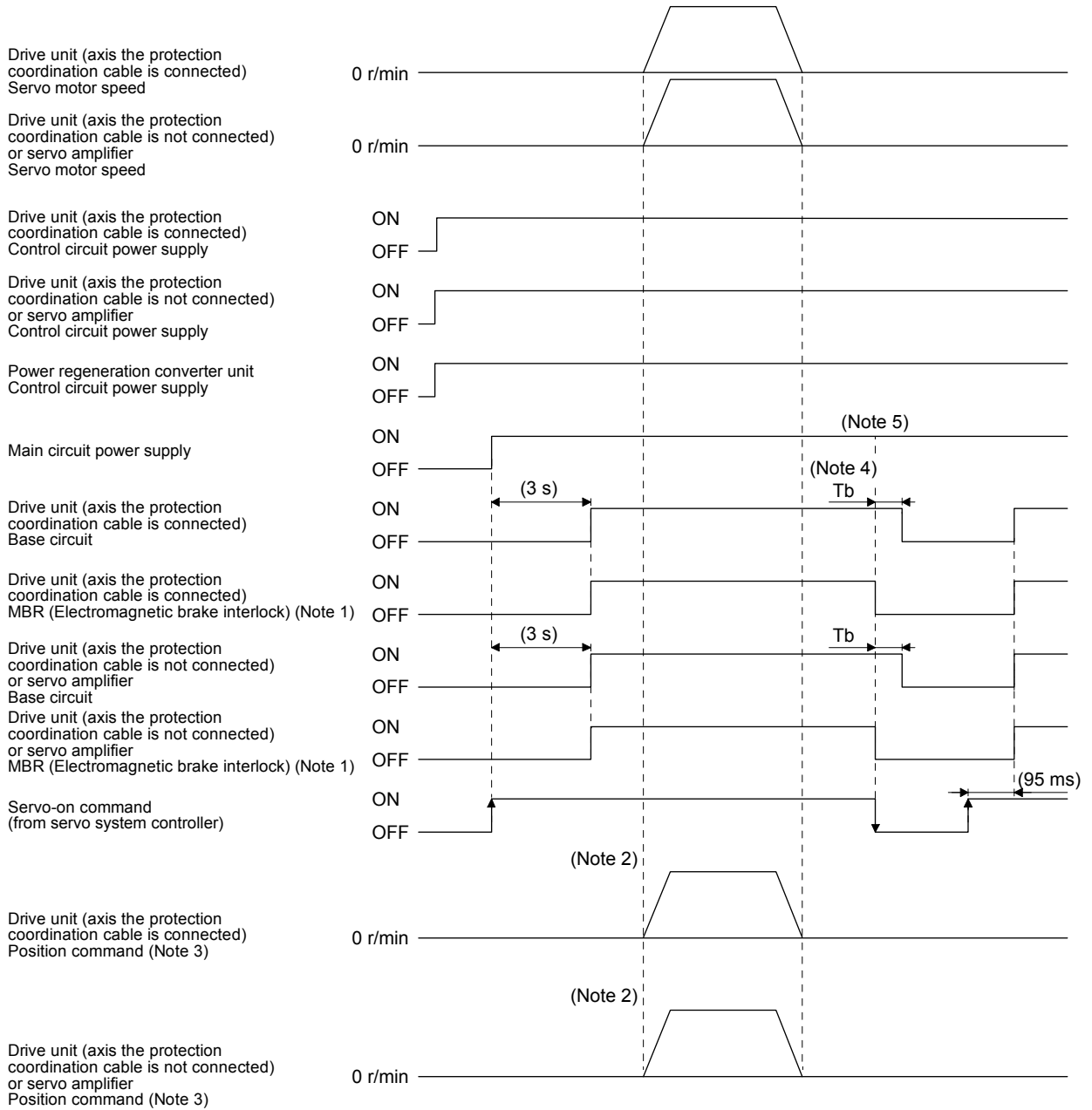

- Note 1. When an electromagnetic brake is installed externally, configure a sequence which operates the electromagnetic brake with MBR as follows.
 ON: Electromagnetic brake is not activated.
 OFF: Electromagnetic brake is activated.
- Note 2. Give a position command after the external electromagnetic brake is released.
- Note 3. This is in position control mode.
- Note 4. In [Pr. PC02 Electromagnetic brake sequence output], set a delay time (T_b) from MBR off to base circuit shut-off at servo-off.
- Note 5. The main circuit power does not shut off with servo-off.

3. MR-CV_ POWER REGENERATION CONVERTER UNIT

b) When magnetic contactor drive output is enabled and the status returns to ready-off

When the axis, which the protection coordination cable is connected to, turns to servo-off, the magnetic contactor of the power regeneration converter unit turns off, and the main circuit power supply shuts off. Even when an axis other than the cable connected turns to servo-off, the main circuit power supply will not shut off.

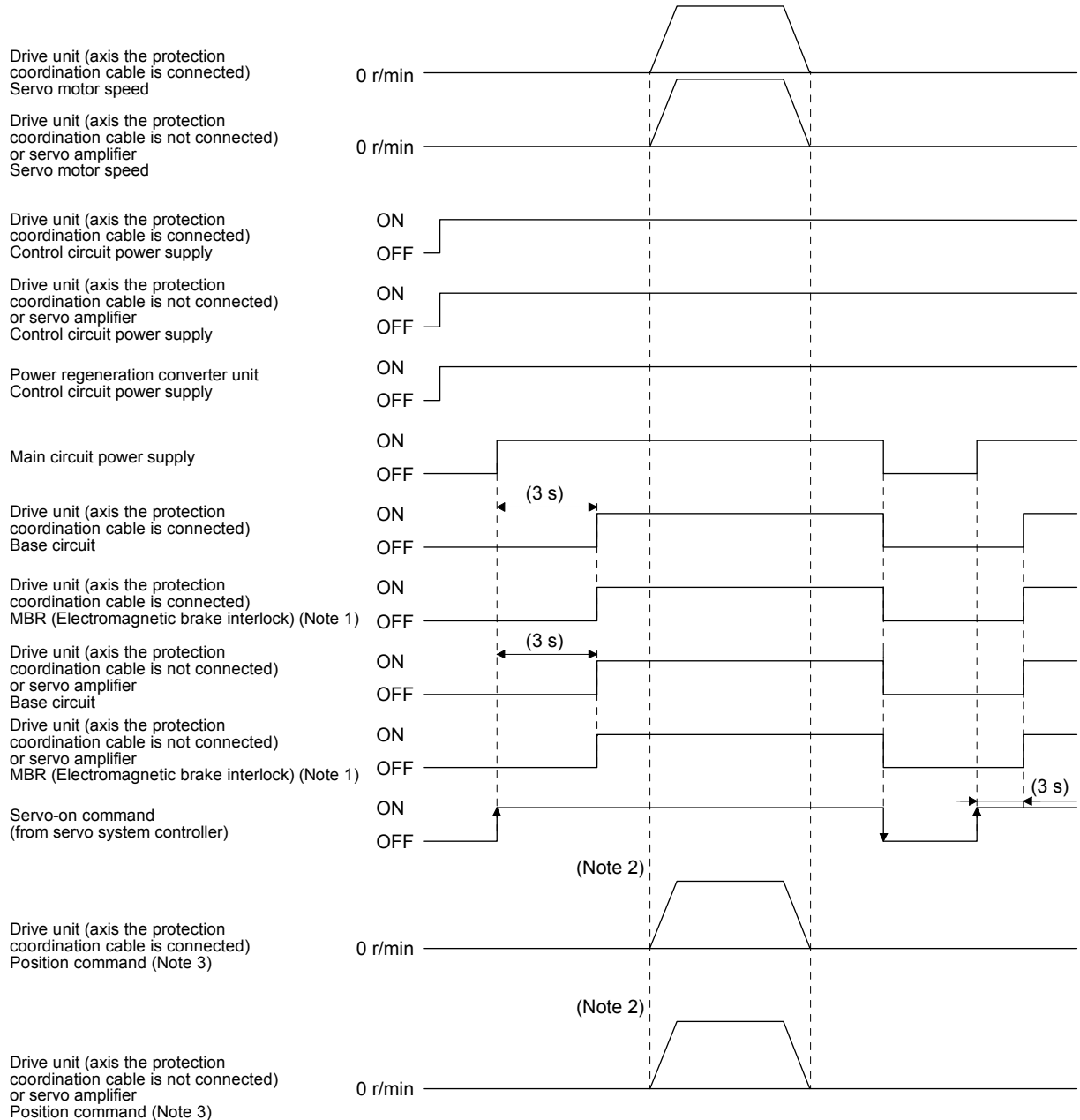

Note 1. When an electromagnetic brake is installed externally, configure a sequence which operates the electromagnetic brake with MBR as follows.

ON: Electromagnetic brake is not activated.

OFF: Electromagnetic brake is activated.

2. Give a position command after the external electromagnetic brake is released.

3. This is in position control mode.

3. MR-CV_ POWER REGENERATION CONVERTER UNIT

c) When magnetic contactor drive output is disabled

When an alarm occurs, turn off the magnetic contactor using the external sequence, and shut off the main circuit power supply.

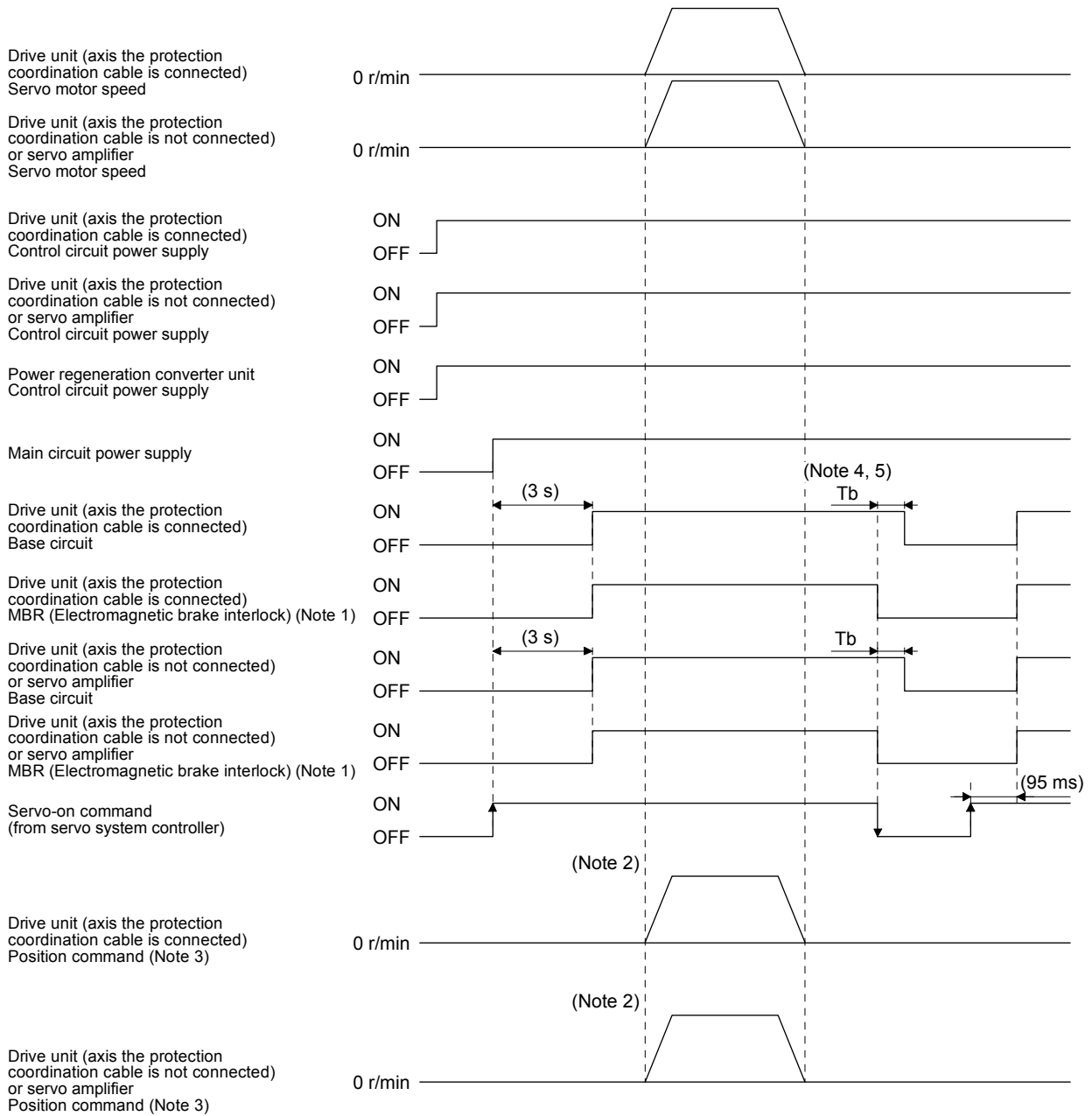

- Note**
- When an electromagnetic brake is installed externally, configure a sequence which operates the electromagnetic brake with MBR as follows.
 - ON: Electromagnetic brake is not activated.
 - OFF: Electromagnetic brake is activated.
 - Give a position command after the external electromagnetic brake is released.
 - This is in position control mode.
 - In [Pr. PC02 Electromagnetic brake sequence output], set a delay time (T_b) from MBR off to base circuit shut-off at servo-off.
 - The base circuit remains ready-on status at servo-off. When the status is ready-off, the base circuit and the servo-on command turn off at the same time. ($T_b = 0$)

3. MR-CV_ POWER REGENERATION CONVERTER UNIT

3.3.3 Connectors and pin assignment

POINT
<ul style="list-style-type: none"> ● The pin assignment of the connectors is as viewed from the cable connector wiring section. ● When using the CN24 connector, MR-CVCN24S connector set and a crimping tool are necessary.

(1) Connectors and pin assignment of MR-CV_ power regeneration converter unit

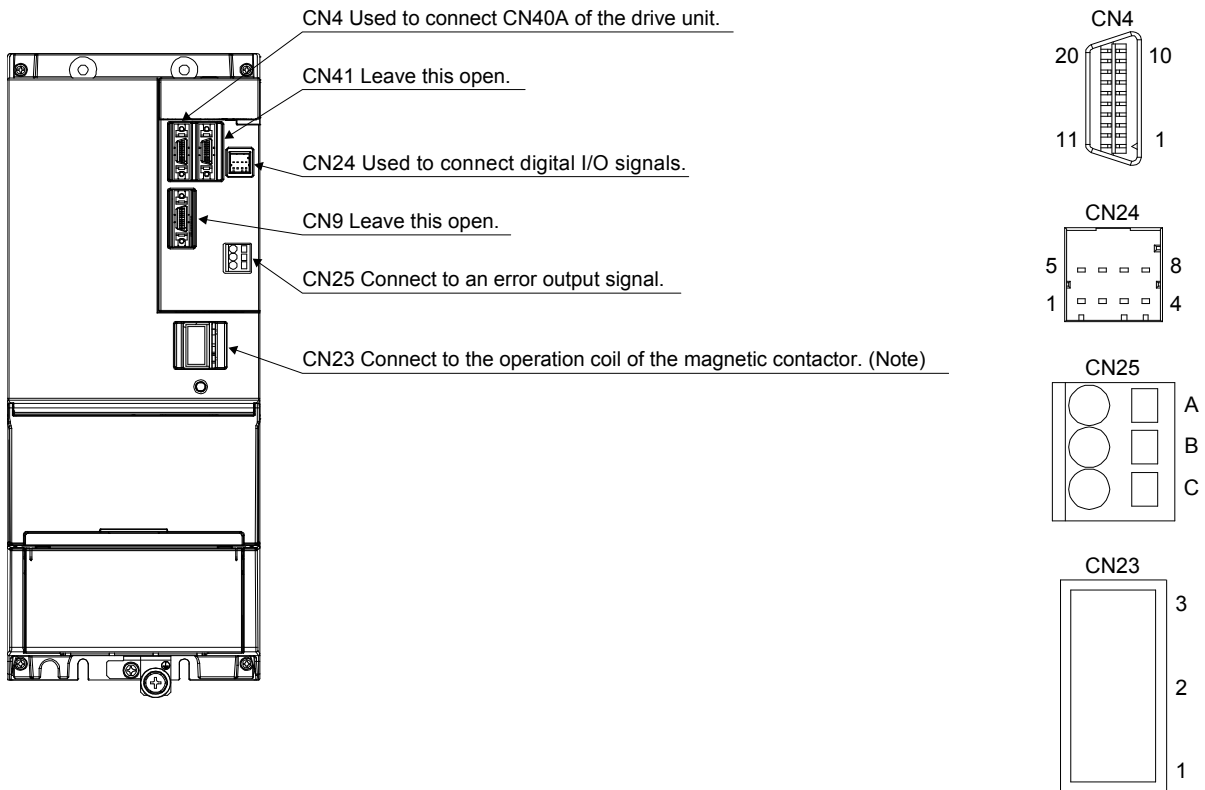

Note. The connector for CN23 and an open tool are supplied with the power regeneration converter unit.

3. MR-CV_ POWER REGENERATION CONVERTER UNIT

(2) Connecting wire to CN25

POINT
●When stripping wire, be careful not to damage the conductor. Using this equipment with the conductor damaged may cause an insulation failure, loose connection, or wire breakage.
●After connecting wire, pull each wire lightly to confirm that the wire does not easily come out. Using this equipment without connecting the wire properly may cause a loose connection and wire breakage.
●After connecting wire, be careful that the tension (torsional force) of the wire is not directly applied to the part where the closed part of the terminal block and the wire are connected. Applying the torsional force may cause a loose connection or wire breakage.
●When opening the spring, do not apply an extreme force. Otherwise, the housing may break.

(a) Fabrication on cable insulator

Stripped length of the wire insulator should be approx. 5 to 6 mm. The appropriate stripped length of wire depends on the wire type, etc. Set the length considering their status.

Stranded wire or solid wire of AWG 28 to 14 can be connected to CN25. Any wire whose insulator is too thick to be inserted to the insertion hole of CN25 cannot be used.

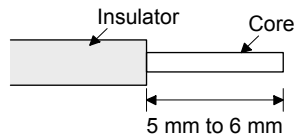

Twist strands lightly and straighten them as follows.

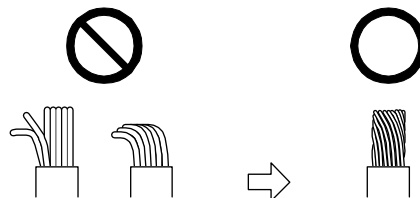

3. MR-CV_ POWER REGENERATION CONVERTER UNIT

(b) Inserting wire

Insert only one wire in each wire insertion hole of CN25 (the round hole).

- 1) Insert a driver diagonally in the square hole.

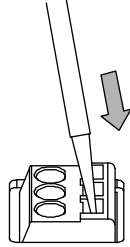

- 2) Stand the driver up pressing to the end. If inserted properly, the driver keeps standing with hands off.

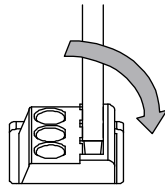

- 3) Insert the properly-stripped wire in the wire insertion hole.

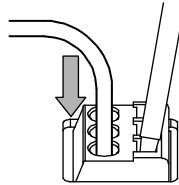

- 4) Once the wire is pressed to the end, pull out the driver holding the wire.

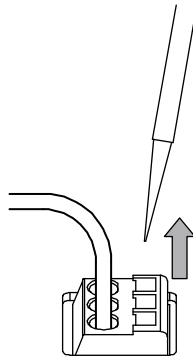

- 5) Pull the wire lightly to confirm that the wire does not come out. Do not pull the wire too hard. In addition, make sure that no conductor wire sticks out of the connector. You can remove the wire with the driver inserted in the square hole.

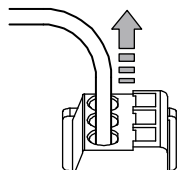

3. MR-CV_ POWER REGENERATION CONVERTER UNIT

(c) Drivers to be used

For mounting wire, dedicated drivers shown in the following are recommended.

Model number	Type	Brand
210-720	Standard type (Made in Europe)	WAGO
210-120J	Standard type (Made in Japan)	
210-657J	Mini type (Made in Japan)	

When using general drivers, the width must be 3.5 mm. Those drivers, which are too large to be inserted in the driver slot, or are unable to open the springs properly, cannot be used.

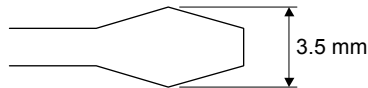

3. MR-CV_ POWER REGENERATION CONVERTER UNIT

3.3.4 Signal (device) explanations

The following table lists signals (devices) of the power regeneration converter unit.

For the I/O interfaces (symbols in I/O division column in the table), refer to section 3.3.7.

(1) I/O signal connector (CN24)

Signal (device)	Symbol	Connector pin No.	Function and application	I/O division
Forced stop	EM1	CN24-1	To enable EM1, set the converter setting rotary switch (SW1) of the power regeneration converter unit to "4". When EM1 is turned off, the converter unit will be in a forced stop state. In this state, the magnetic contactor turns off, [AL. E9 Main circuit off warning] occurs in the drive unit, and the servo-on turns off. The forced stop state will be reset when EM1 is turned on.	DI
Reset	RES	CN24-2	This signal is used for resetting alarms. Turn RES off after it has been on for 100 ms or longer. Some alarms cannot be reset by RES. Refer to chapter 6 for the alarms that can be reset. If RES is turned on while no alarm is occurring, the state will be ready-off. Do not turn this device on during an operation as it is not for stopping the operation.	DI
Alarm	ALM	CN24-3	When an alarm occurs, ALM turns off.	DO
Digital I/F power supply input	DICOM	CN24-4	Input 24 V DC (24 V DC \pm 10% 500 mA) for I/O interface. The power supply capacity varies, depending on the number of I/O interface points to be used. For sink interface, connect + of the 24 V DC external power supply. For source interface, connect - of the 24 V DC external power supply.	
Ready	RDYA	CN24-5	RDYA turns on when the power regeneration converter unit is ready. It is a reverse logic to RDYB. RDYA remains off until the unit turns on after the power is turned on.	DO
Operation permission	RDYB	CN24-6	RDYB turns on when an error occurs in the power regeneration converter unit and when the reset is inputted. It is a reverse logic to RDYA. RDYB remains off until the unit turns off after the power is turned on.	DO
Converter reset	RSO	CN24-7	RSO turns on when RES is inputted to the power regeneration converter unit.	DO
Digital I/F common	DOCOM	CN24-8	This is a common terminal for input signal. This is separated from LG. For sink interface, connect - of the 24 V DC external power supply. For source interface, connect + of the 24 V DC external power supply.	

(2) Alarm output connector (CN25)

Signal (device)	Symbol	Connector pin No.	Function and application	I/O division
Alarm output	A B C	CN25-1 CN25-2 CN25-3	This connector, having a form C contact, outputs an alarm when the protective function of the power regeneration converter unit is activated and the power output to the drive unit is stopped. Abnormal: B and C are not conducted. (A and C are conducted.) Normal: B and C are conducted. (A and C are not conducted.)	DO

(3) Magnetic contactor control connector (CNP23)

Signal (device)	Symbol	Connector pin No.	Function and application	I/O division
Magnetic contactor drive output	MC1	CN23-1	Connect this device to the operation coil of the magnetic contactor and the power supply for controlling the magnetic contactor. When the power regeneration converter unit receives a start command from the drive unit, MC1 (CNP23-1 pin) and MC2 (CN23-3 pin) will be shorted. When not executing control using the connector for controlling magnetic contactor, set the converter setting rotary switch (SW1) of the power regeneration converter unit to "1". (Refer to section 3.4.3.)	
	MC2	CN23-3		

3. MR-CV_ POWER REGENERATION CONVERTER UNIT

3.3.5 Alarm occurrence timing chart



CAUTION

● When an alarm has occurred, remove its cause, make sure that the operation signal is not being inputted, ensure safety, and reset the alarm before restarting operation.

- (1) Connecting one drive unit to one power regeneration converter unit
 - (a) When magnetic contactor drive output is enabled

1) Power regeneration converter unit

When an alarm occurs in the power regeneration converter unit, the magnetic contactor turns off and the main circuit magnetic contactor shuts off. The drive unit in operation stops. To deactivate the alarm, cycle the control circuit power or request the operation from the driver unit. However, the alarm cannot be deactivated unless its cause is removed.

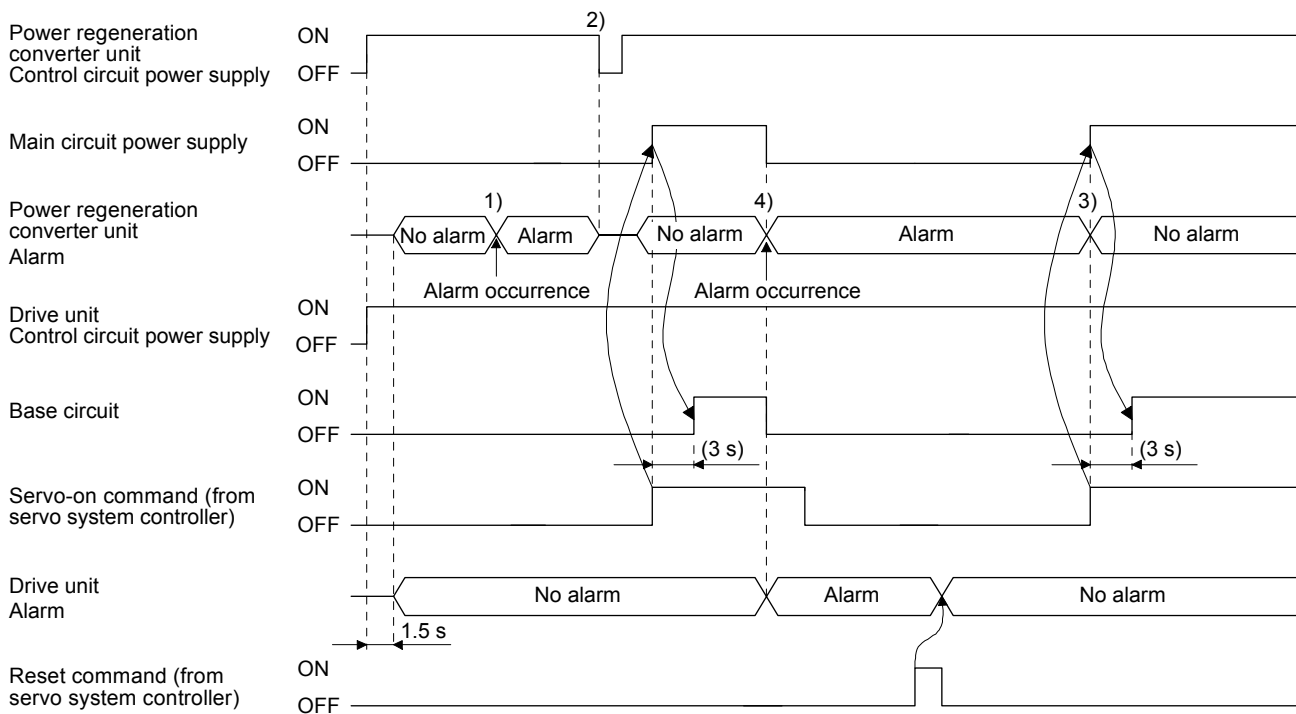

- 1) in figure Even if an alarm occurs in the power regeneration converter unit when the drive unit is at servo-off, the alarm is not detected.
- 2) and 3) in figure To deactivate the alarm of the power regeneration converter unit, cycle the power of the power regeneration converter unit (2)), or turn on the servo-on command (3)). Refer to section 6.1 for the alarms that can be reset with the servo-on command on.
- 4) in figure If an alarm occurs in the power regeneration converter unit when the drive unit is at servo-on, the alarm also occurs in the drive unit, and the drive unit becomes servo-off.

3. MR-CV_ POWER REGENERATION CONVERTER UNIT

2) Drive unit

When an alarm occurs in the drive unit, the base circuit shuts off and the servo motor coasts.

When an external dynamic brake is used, the external dynamic brake is activated to stop the servo motor.

To deactivate the alarm, cycle the control circuit power, or give the error reset or CPU reset command from the servo system controller. However, the alarm cannot be deactivated

unless its cause is removed.

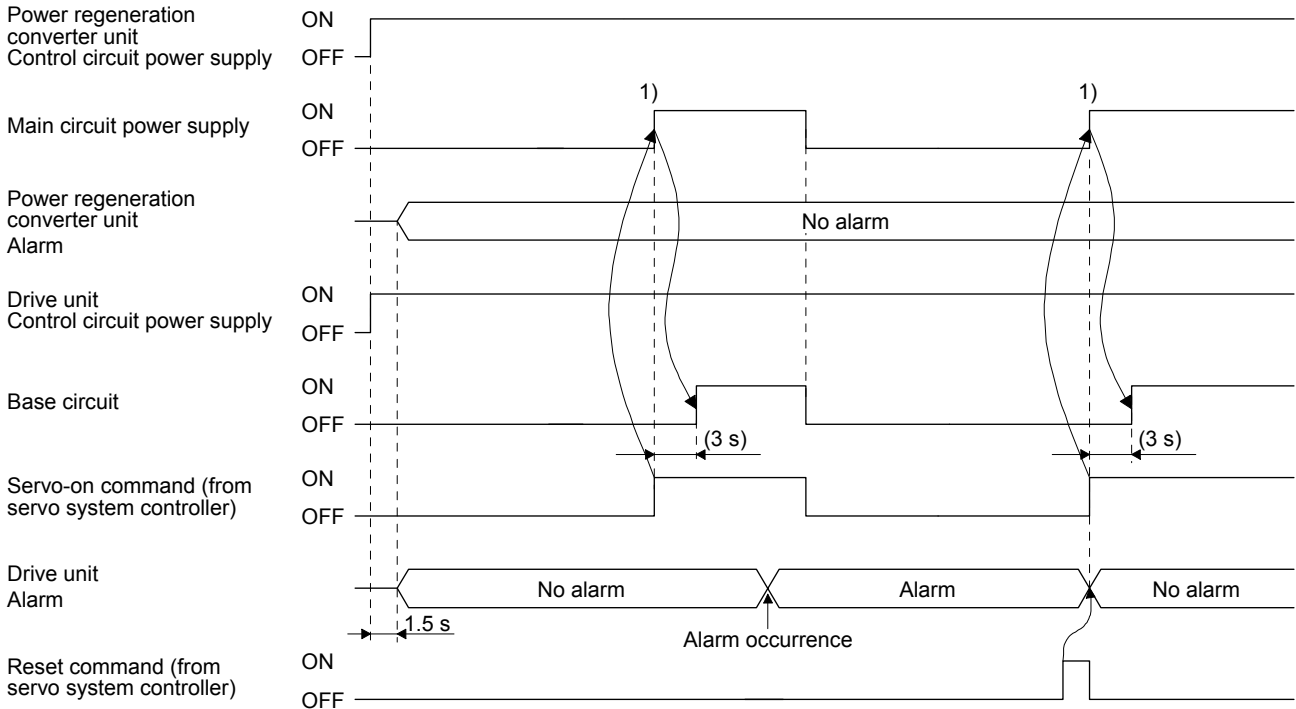

1) in figure

After the drive unit has started, and when the drive unit and power regeneration converter unit have no alarms, the main circuit power is supplied.

3. MR-CV_ POWER REGENERATION CONVERTER UNIT

(b) When magnetic contactor drive output is disabled

1) Power regeneration converter unit

When an alarm occurs in the power regeneration converter unit, servo-off occurs. However, the main circuit power supply does not shut off; therefore, shut off the main circuit power supply with the external sequence. When the alarm is deactivated in the power regeneration converter unit, (and in the drive unit if an alarm has also occurred in the drive unit), turn on the error reset command from the servo system controller to resume the operation.

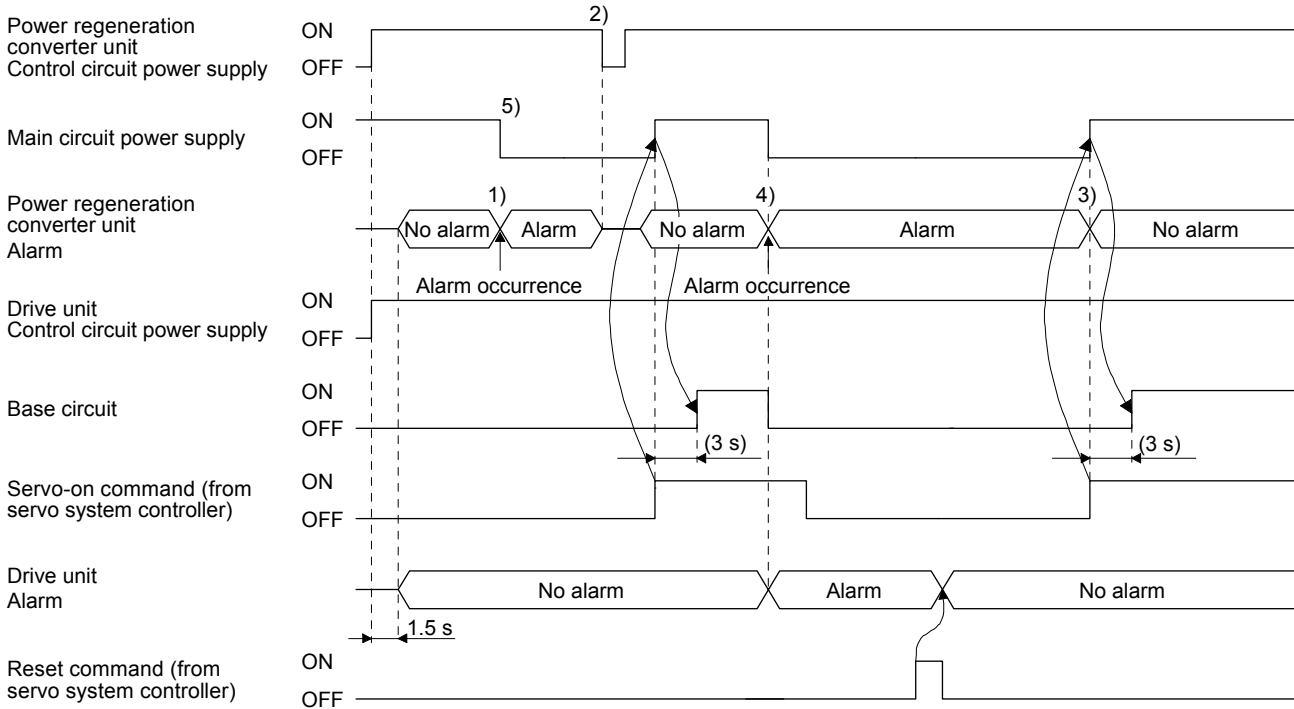

- 1) in figure Even if an alarm occurs in the power regeneration converter unit when the drive unit is at servo-off, the alarm is not detected.
- 2) and 3) in figure To deactivate the alarm of the power regeneration converter unit, cycle the power of the power regeneration converter unit (2)), or turn on the servo-on command (3)). Refer to section 6.1 for the alarms that can be reset with the servo-on command on.
- 4) in figure If an alarm occurs in the power regeneration converter unit when the drive unit is at servo-on, the alarm also occurs in the drive unit, and the drive unit becomes servo-off.
- 5) in figure Shut off the main circuit power supply with the external sequence at the same time with the alarm occurrence.

3. MR-CV_ POWER REGENERATION CONVERTER UNIT

2) Drive unit

When an alarm occurs in the drive unit, servo-off occurs. However, the main circuit power supply does not shut off; therefore, shut off the main circuit power supply with the external sequence. After the alarm is deactivated in the drive unit, turn on the error reset command from the servo system controller to resume the operation.

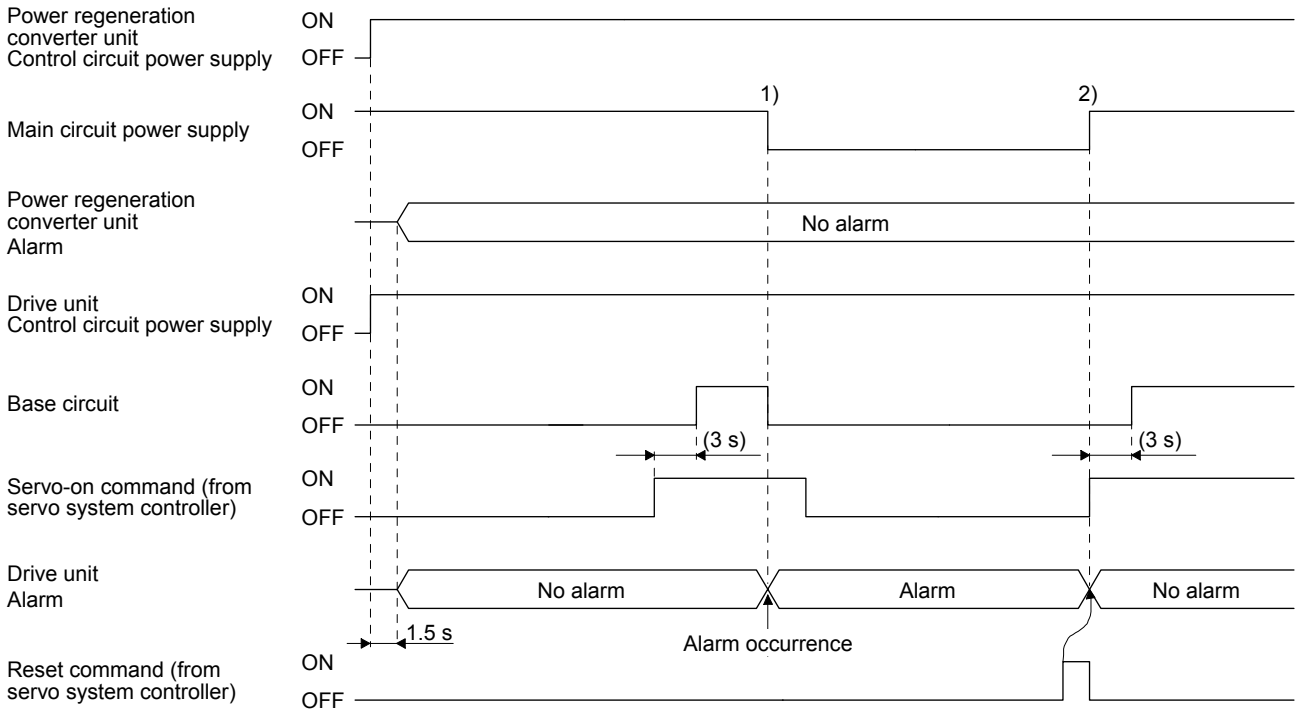

1) in figure When an alarm occurs in the drive unit, shut off the main circuit power supply with the external sequence.

2) in figure Turn on the main circuit power supply after the alarm in the drive unit is deactivated.

3. MR-CV_ POWER REGENERATION CONVERTER UNIT

(2) Connecting multiple drive units and servo amplifiers to one power regeneration converter unit

(a) When magnetic contactor drive output is enabled

1) Power regeneration converter unit

When an alarm occurs in the power regeneration converter unit, the magnetic contactor turns off and the main circuit magnetic contactor shuts off. Make all the axes servo-off by inputting the forced stop signal from the servo system controller to the drive unit or servo amplifier in operation. To deactivate the alarm, cycle the control circuit power or request the operation from the axis which the protection coordination cable is connected to. However, the alarm cannot be deactivated unless its cause is removed.

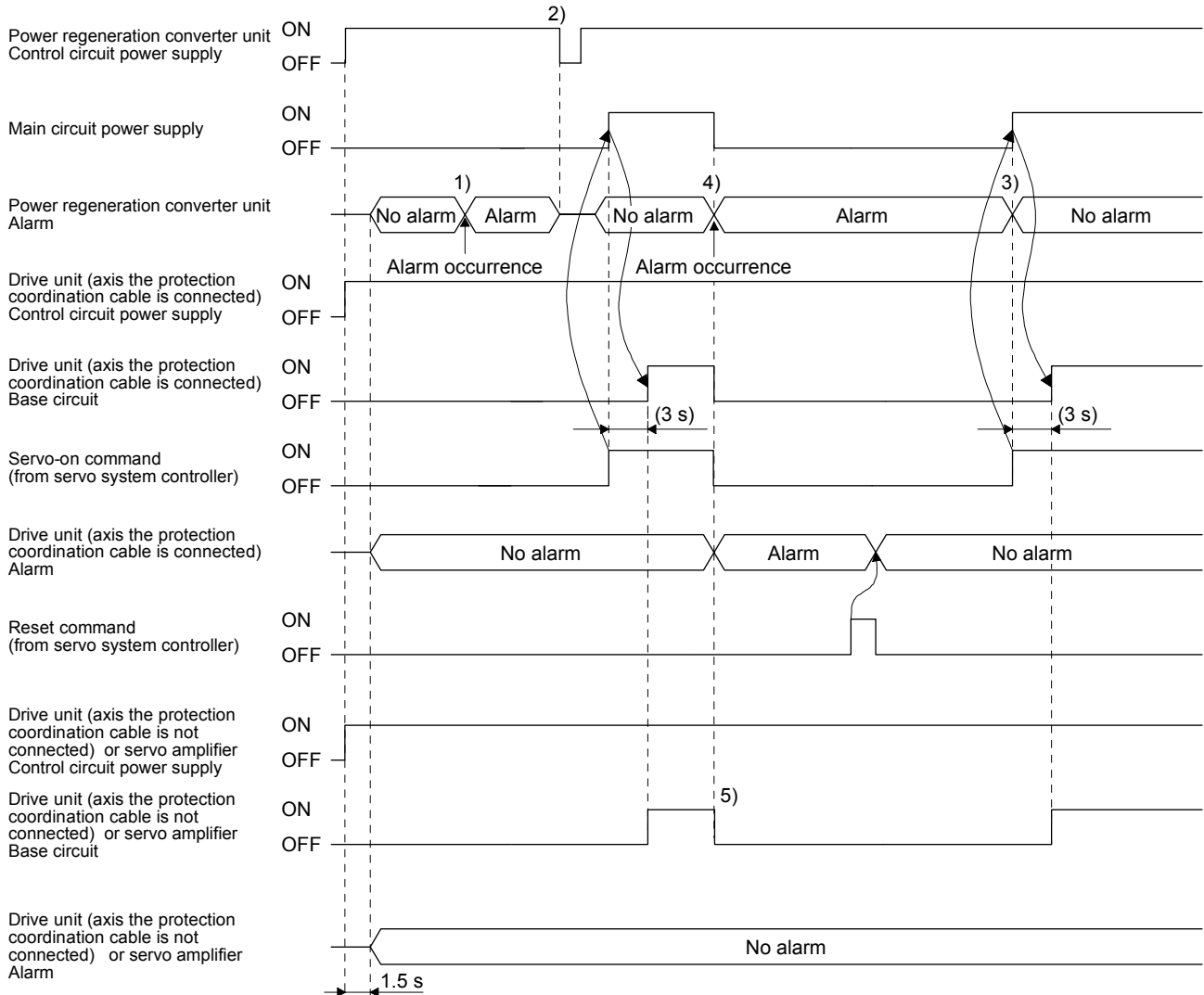

3. MR-CV_ POWER REGENERATION CONVERTER UNIT

- 1) in figure Even if an alarm occurs in the power regeneration converter unit when the drive unit is at servo-off, the alarm is not detected.
- 2) and 3) in figure To deactivate the alarm of the power regeneration converter unit, cycle the power of the power regeneration converter unit (2)), or turn on the servo-on command (3)). Refer to section 6.1 for the alarms that can be reset with the servo-on command on.
- 4) in figure If an alarm occurs in the power regeneration converter unit when the drive unit is at servo-on, the alarm also occurs in the axis which the protection coordination cable is connected to, and the drive unit becomes servo-off.
- 5) in figure When an alarm occurs in the power regeneration converter unit, make all the axes servo-off by inputting the forced stop signal from the servo system controller.

3. MR-CV_ POWER REGENERATION CONVERTER UNIT

2) Drive unit

When an alarm occurs in the drive unit which the protection coordination cable is connected to, the base circuit shuts off and the servo motor coasts. When an alarm occurs in the servo amplifier or drive unit which the protection coordination cable is not connected to, shut off the main circuit power supply by turning off the magnetic contactor with the external sequence. When an external dynamic brake is used, the external dynamic brake is activated to stop the servo motor. When an alarm occurs in any axis, make all the axes servo-off by inputting the forced stop signal from the servo system controller.

To deactivate the alarm, cycle the control circuit power, or give the error reset or CPU reset command from the servo system controller. However, the alarm cannot be deactivated unless its cause is removed.

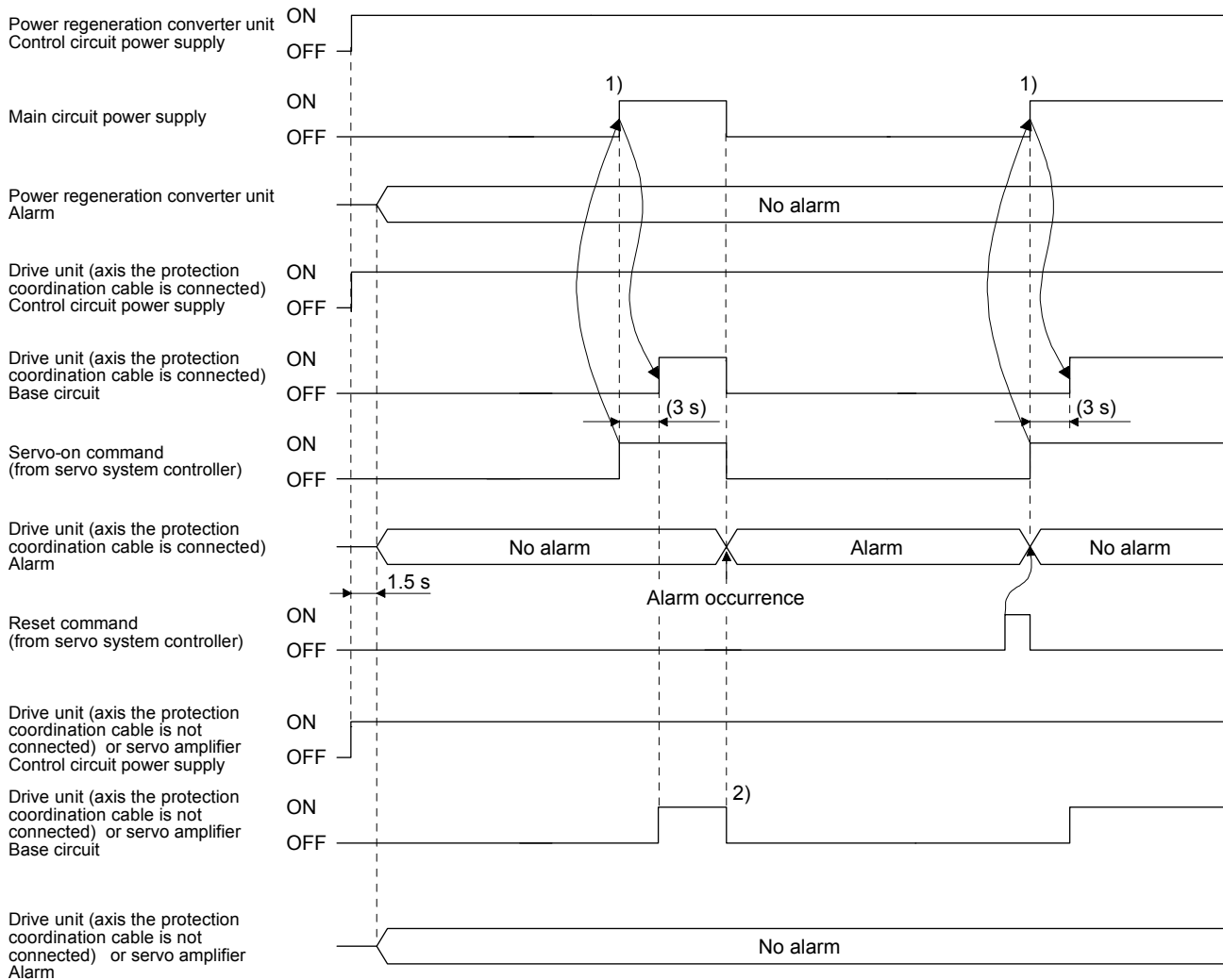

1) in figure

After the drive unit has started, and when the drive unit and power regeneration converter unit have no alarms, the main circuit power is supplied.

2) in figure

When an alarm occurs in any axis, make all the axes servo-off by inputting the forced stop signal from the servo system controller.

3. MR-CV_ POWER REGENERATION CONVERTER UNIT

(b) When magnetic contactor drive output is disabled

1) Power regeneration converter unit

When an alarm occurs in the power regeneration converter unit, servo-off occurs. However, the main circuit power supply does not shut off; therefore, shut off the main circuit power supply with the external sequence. Make all the axes servo-off by inputting the forced stop signal from the servo system controller to the drive unit or servo amplifier in operation. When the alarm is deactivated in the power regeneration converter unit, (and in the drive unit or servo amplifier if an alarm has also occurred in the drive unit or servo amplifier), turn on the error reset command from the servo system controller to resume the operation.

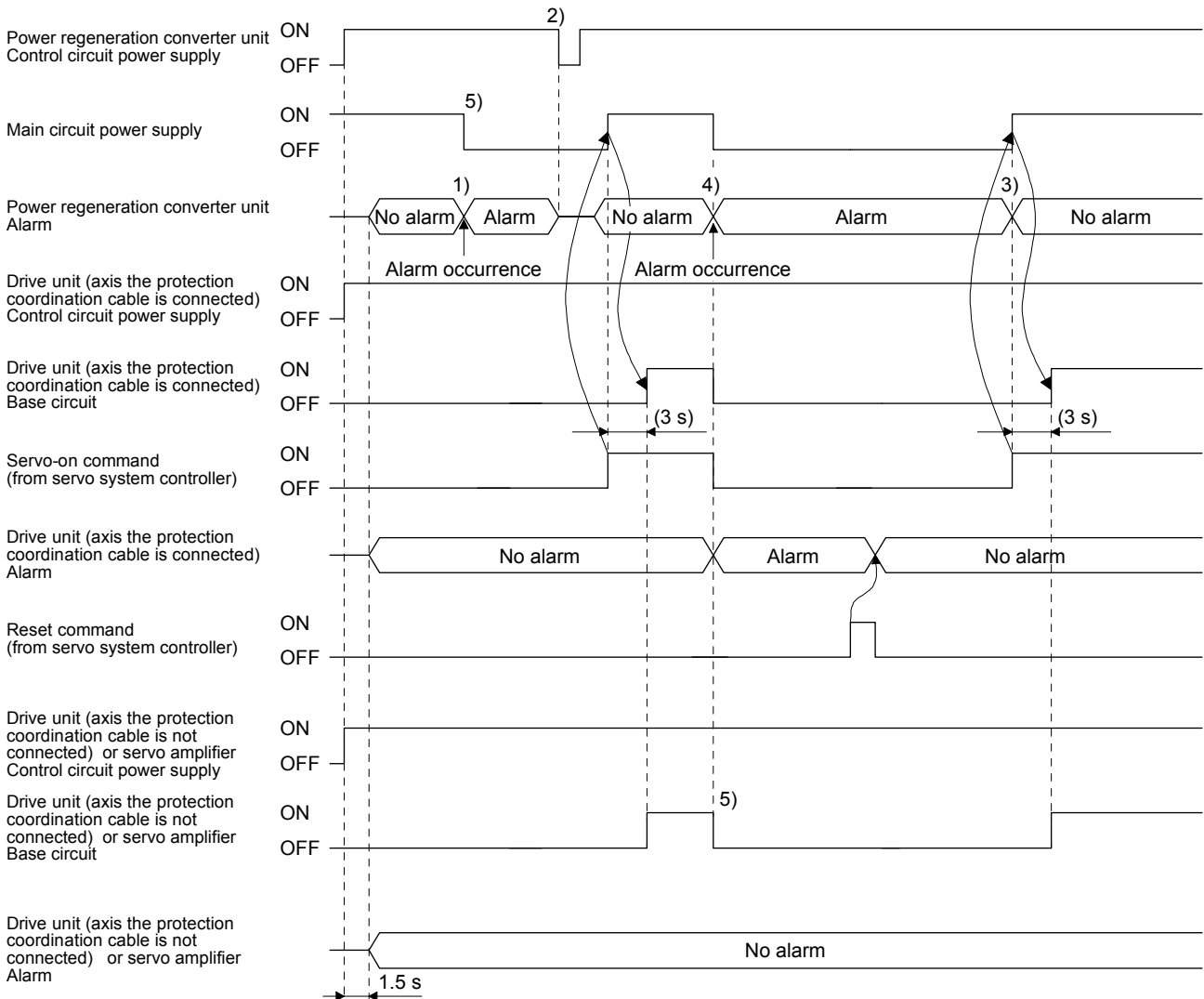

- 1) in figure Even if an alarm occurs in the power regeneration converter unit when the drive unit is at servo-off, the alarm is not detected.
- 2) and 3) in figure To deactivate the alarm of the power regeneration converter unit, cycle the power of the power regeneration converter unit (2)), or turn on the servo-on command (3)). Refer to section 6.1 for the alarms that can be reset with the servo-on command on.
- 4) in figure If an alarm occurs in the power regeneration converter unit when the drive unit is at servo-on, the alarm also occurs in the drive unit, and the drive unit becomes servo-off.
- 5) in figure When an alarm occurs in the power regeneration converter unit, make all the axes servo-off by inputting the forced stop signal from the servo system controller.

3. MR-CV_ POWER REGENERATION CONVERTER UNIT

2) To drive unit or servo amplifier

When an alarm occurs in the drive unit or servo amplifier, servo-off occurs. However, the main circuit power supply does not shut off; therefore, shut off the main circuit power supply with the external sequence. Make all the axes servo-off by inputting the forced stop signal from the servo system controller to the drive unit or servo amplifier in operation. After the alarm is deactivated in the drive unit or servo amplifier, turn on the error reset command from the servo system controller to resume the operation.

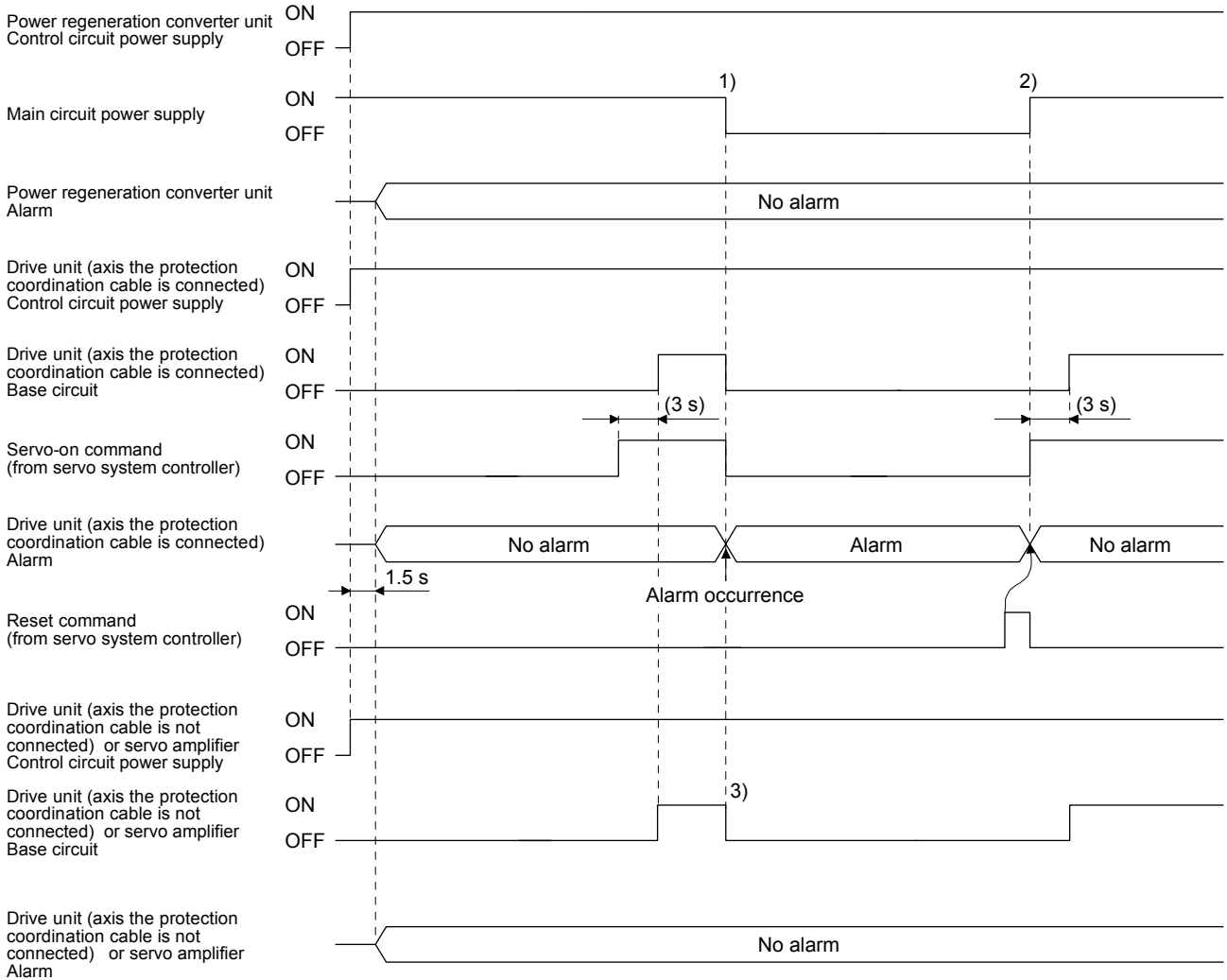

- 1) in figure When an alarm occurs in the drive unit, shut off the main circuit power supply with the external sequence.
- 2) in figure Turn on the main circuit power supply after the alarm in the drive unit is deactivated.
- 3) in figure When an alarm occurs in any axis, make all the axes servo-off by inputting the forced stop signal from the servo system controller.

3. MR-CV_ POWER REGENERATION CONVERTER UNIT

3.3.6 Forced stop in the power regeneration converter unit

(1) Connecting one drive unit to one power regeneration converter unit

(a) When magnetic contactor drive output is enabled

When EM1 (Forced stop) is disabled in the power regeneration converter unit, the magnetic contactor turns off and the main circuit power supply shuts off. The base circuit of the drive unit in operation shuts off, and [AL. E9 Main circuit off warning] appears on the drive unit. When EM1 is enabled in the power regeneration converter unit, the magnetic contactor turns on, the main circuit power is supplied, and then the drive unit automatically resumes the operation.

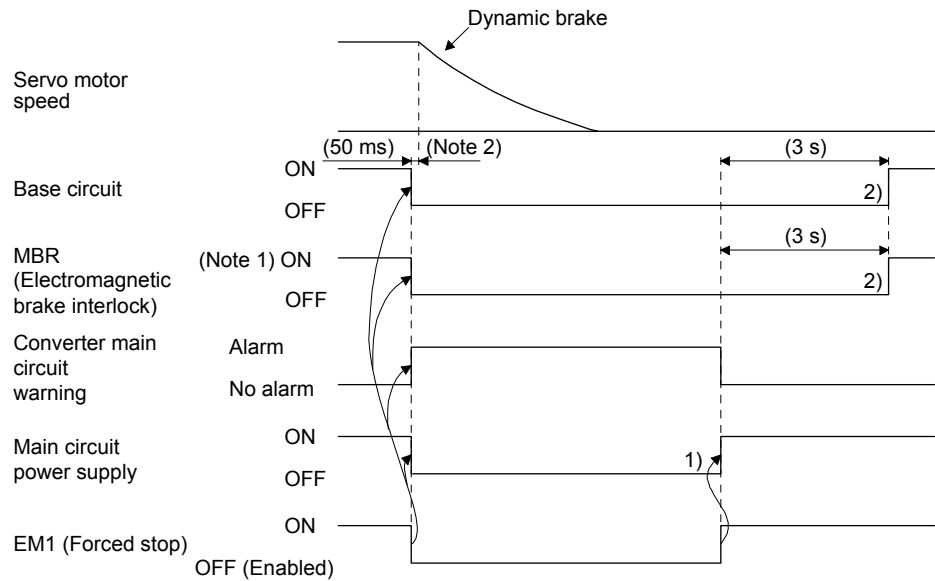

Note 1. When an electromagnetic brake is installed externally, configure a sequence which operates the electromagnetic brake with MBR as follows.

ON: Electromagnetic brake is not activated.

OFF: Electromagnetic brake is activated.

Note 2. There are delays caused by a magnetic contactor built into the external dynamic brake (about 50 ms) and by external relays.

1) in figure When EM1 is enabled in the power regeneration converter unit, the main circuit power is supplied.

2) in figure When the capacitor in the main circuit is fully charged, the base circuit and MBR turn on.

3. MR-CV_ POWER REGENERATION CONVERTER UNIT

(b) When magnetic contactor drive output is disabled

When EM1 (Forced stop) is disabled in the power regeneration converter unit, the base circuit of the drive unit that is in operation shuts off, and [AL. E9 Main circuit off warning] appears on the drive unit. When EM1 is enabled in the power regeneration converter unit, the drive unit automatically resumes the operation.

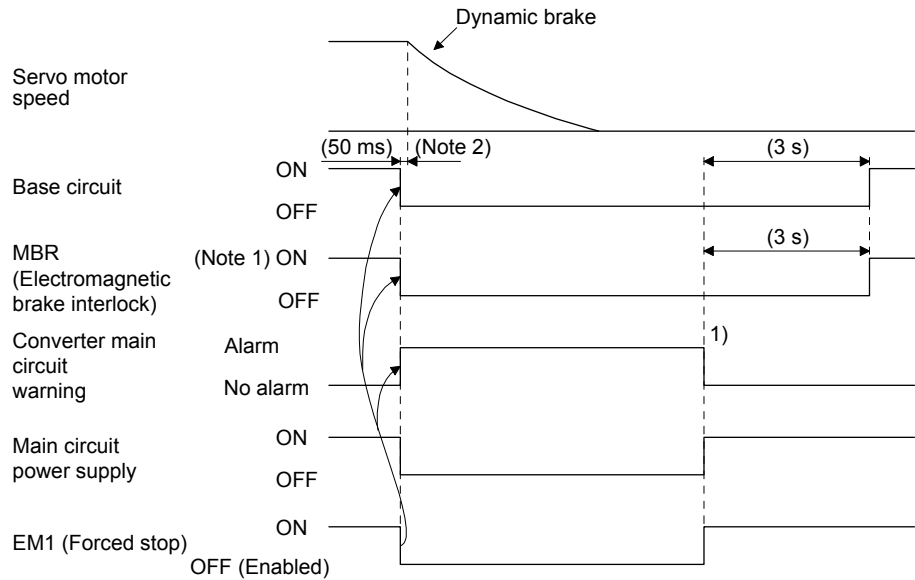

- Note 1. When an electromagnetic brake is installed externally, configure a sequence which operates the electromagnetic brake with MBR as follows.
 ON: Electromagnetic brake is not activated.
 OFF: Electromagnetic brake is activated.
- Note 2. There are delays caused by a magnetic contactor built into the external dynamic brake (about 50 ms) and by external relays.

1) in figure

When EM1 is enabled, the converter main circuit off warning is released.

3. MR-CV_ POWER REGENERATION CONVERTER UNIT

(2) Connecting multiple drive units and servo amplifiers to one power regeneration converter unit

POINT

● The EM1 (forced stop) of the power regeneration converter unit and drive units should be turned off simultaneously.

(a) When magnetic contactor drive output is enabled

When EM1 (Forced stop) is disabled in the power regeneration converter unit, the magnetic contactor turns off and the main circuit power supply shuts off. The base circuit of the drive unit in operation shuts off, and [AL. E9 Main circuit off warning] appears on the drive unit. When EM1 is enabled in the power regeneration converter unit, the magnetic contactor turns on, the main circuit power is supplied, and then the drive unit automatically resumes the operation.

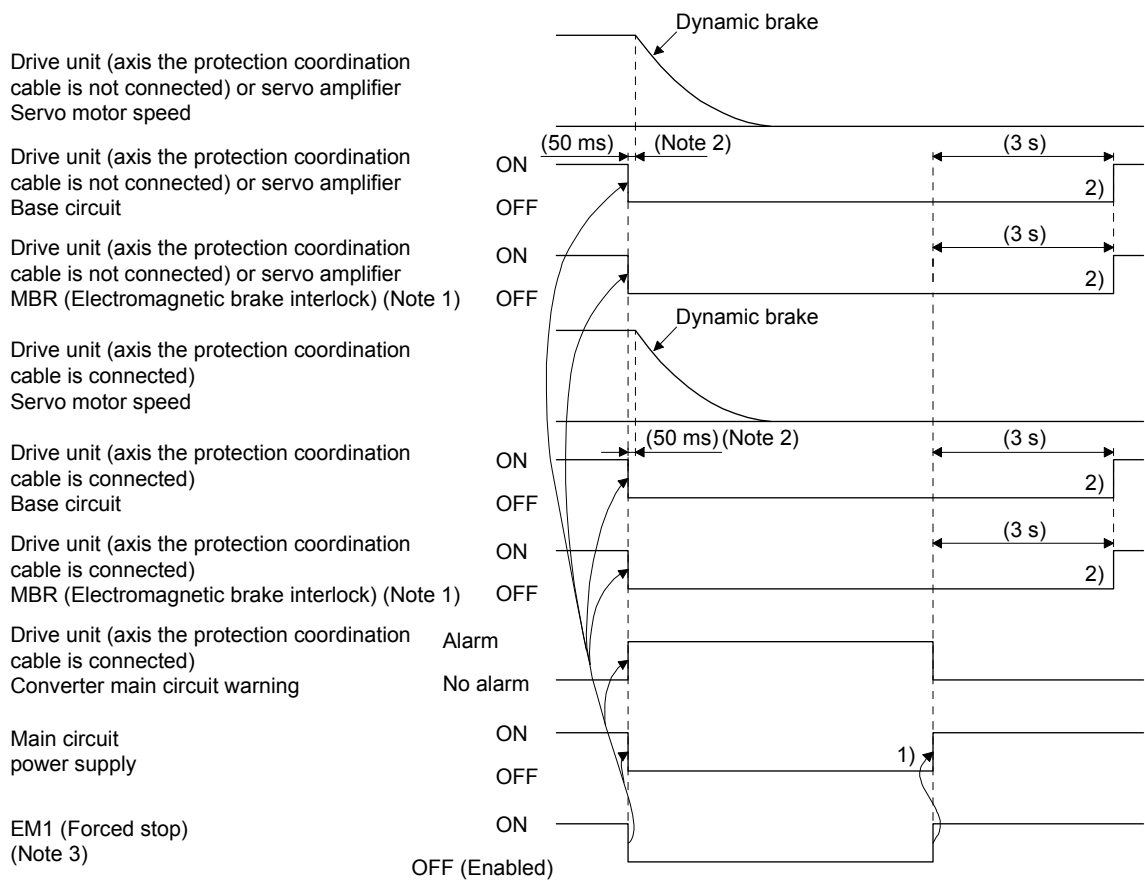

- Note 1. When an electromagnetic brake is installed externally, configure a sequence which operates the electromagnetic brake with MBR as follows.
 ON: Electromagnetic brake is not activated.
 OFF: Electromagnetic brake is activated.
2. There are delays caused by a magnetic contactor built into the external dynamic brake (about 50 ms) and by external relays.
3. The EM1 (forced stop) of the power regeneration converter unit and drive units should be turned off simultaneously.

- 1) in figure When EM1 is enabled in the power regeneration converter unit, the main circuit power is supplied.
- 2) in figure When the capacitor in the main circuit is fully charged, the base circuit and MBR turn on.

3. MR-CV_ POWER REGENERATION CONVERTER UNIT

(b) When magnetic contactor drive output is disabled

When EM1 (Forced stop) is disabled in the power regeneration converter unit, the base circuit of the drive unit that is in operation shuts off, and [AL. E9 Main circuit off warning] appears on the drive unit. When EM1 is enabled in the power regeneration converter unit, the magnetic contactor turns on, the main circuit power is supplied, and then the drive unit automatically resumes the operation.

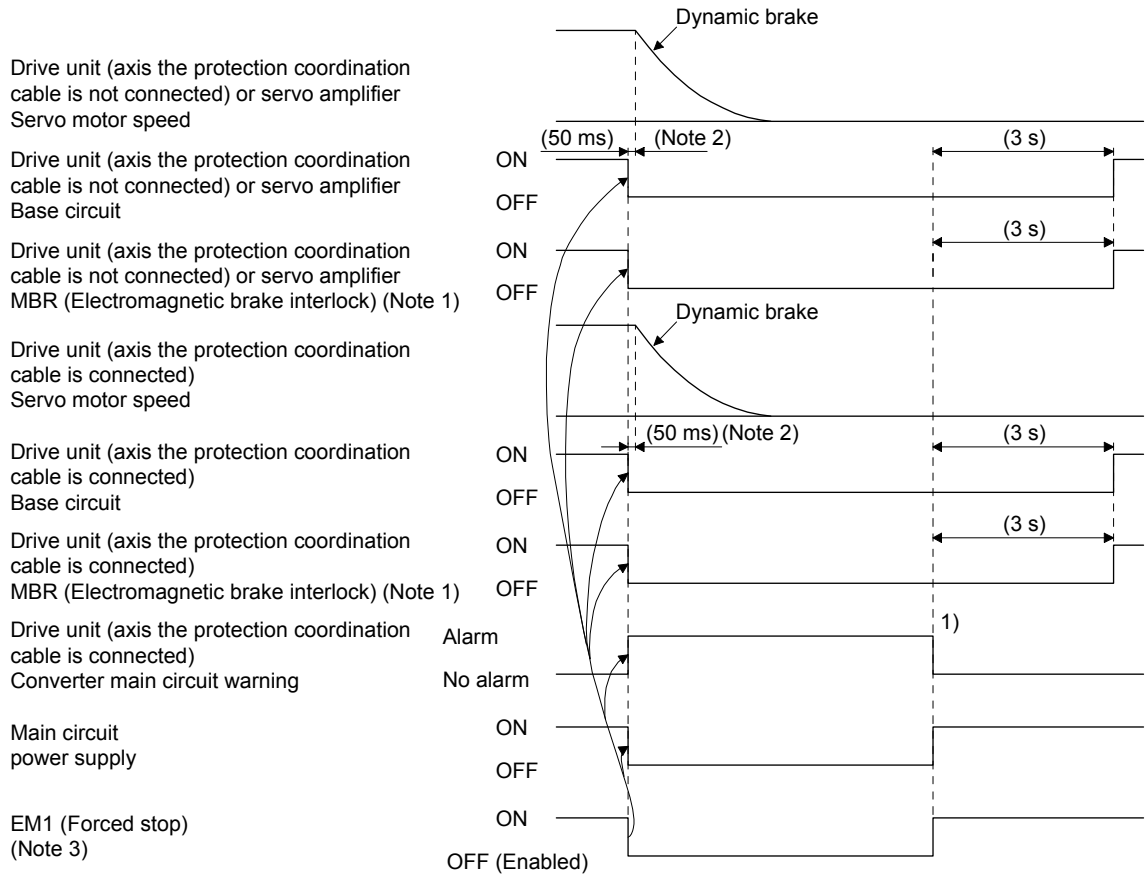

- Note 1. When an electromagnetic brake is installed externally, configure a sequence which operates the electromagnetic brake with MBR as follows.
 ON: Electromagnetic brake is not activated.
 OFF: Electromagnetic brake is activated.
2. There are delays caused by a magnetic contactor built into the external dynamic brake (about 50 ms) and by external relays.
3. The EM1 (forced stop) of the power regeneration converter unit and drive units should be turned off simultaneously.

1) in figure When EM1 is enabled, the converter main circuit off warning is released.

3. MR-CV_ POWER REGENERATION CONVERTER UNIT

3.3.7 Interfaces

(1) Sink I/O interface

(a) Digital input interface DI

This is an input circuit in which photocoupler cathode side is the input terminal. Transmit signals from sink (open-collector) type transistor output, relay switch, etc. The following is a connection diagram for sink input. Refer to (2) in this section for source input.

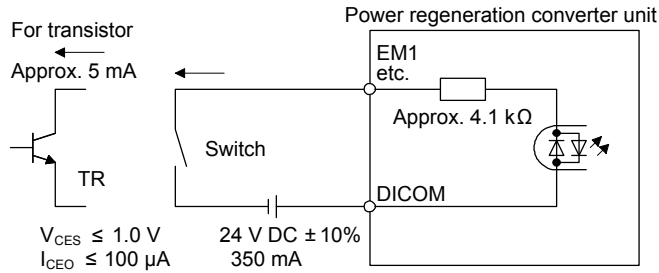

(b) Digital output interface DO

This is a circuit in which the collector of the output transistor is the output terminal. When the output transistor is turned on, the current will flow to the collector terminal.

A lamp, relay, or photocoupler can be driven. Install a diode (D) for an inductive load, or install an inrush current suppressing resistor (R) for a lamp load.

(Rated current: 40 mA or less, maximum current: 50 mA or less, inrush current: 100 mA or less) A maximum of 2.6 V voltage drop occurs in the power regeneration converter unit.

The following shows a connection diagram for sink output. Refer to (2) in this section for source output.

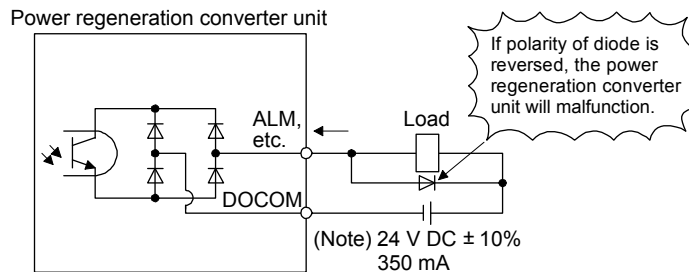

Note. If the voltage drop (maximum of 2.6 V) interferes with the relay operation, apply a high voltage (maximum of 26.4 V) from an external source.

3. MR-CV_ POWER REGENERATION CONVERTER UNIT

(2) Source I/O interface

In this power regeneration converter unit, source type I/O interfaces can be used.

(a) Digital input interface DI

This is an input circuit in which the anode of the photocoupler is the input terminal. Transmit signals from source (open-collector) type transistor output, relay switch, etc.

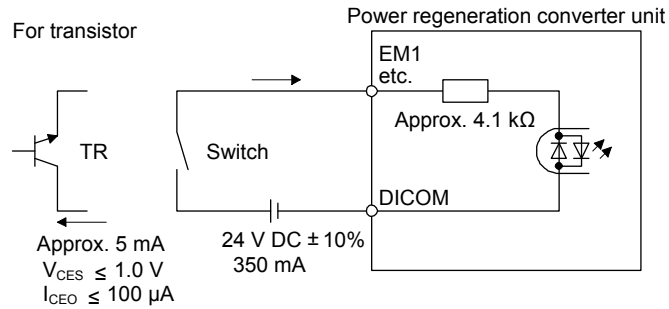

(b) Digital output interface DO

This is a circuit in which the emitter of the output transistor is the output terminal. When the output transistor is turned on, the current will flow from the output terminal to a load.

A maximum of 2.6 V voltage drop occurs in the power regeneration converter unit.

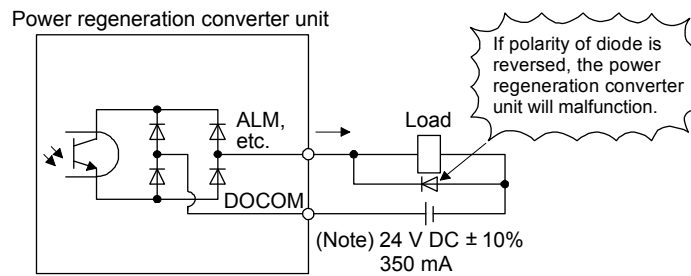

Note. If the voltage drop (maximum of 2.6 V) interferes with the relay operation, apply a high voltage (maximum of 26.4 V) from an external source.

(3) Alarm output

B and C are conducted in normal operation of the power regeneration converter unit. When an alarm occurs, A and C are conducted. Connect to an error output (A/B/C) via a relay coil, etc.

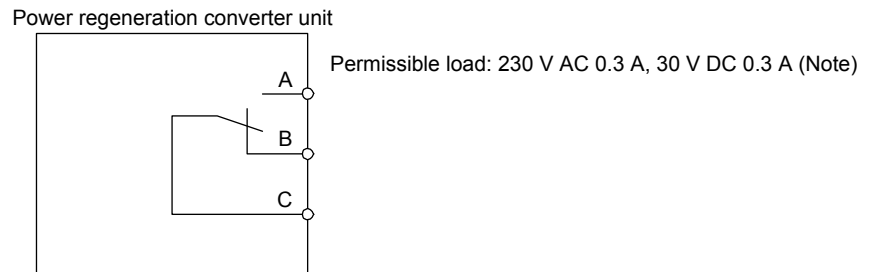

Note. To comply with the IEC/EN/UL/CSA standard, keep it 30 V DC or lower.

3. MR-CV_ POWER REGENERATION CONVERTER UNIT

3.3.8 Grounding

● Ground the power regeneration converter unit, drive unit, and servo motor securely.

⚠ WARNING ● To prevent an electric shock, be sure to connect the protective earth (PE) terminal (marked ⊕) of the power regeneration converter unit and the drive unit to the protective earth (PE) of the cabinet.

The drive unit switches the power transistor on-off to supply power to the servo motor. Depending on the wiring and ground cable routing, the drive unit may be affected by the switching noise (due to di/dt and dv/dt) of the transistor. Be sure to ground to prevent such a fault by referring to the following diagram. To conform to the EMC Directive, refer to "EMC Installation Guidelines".

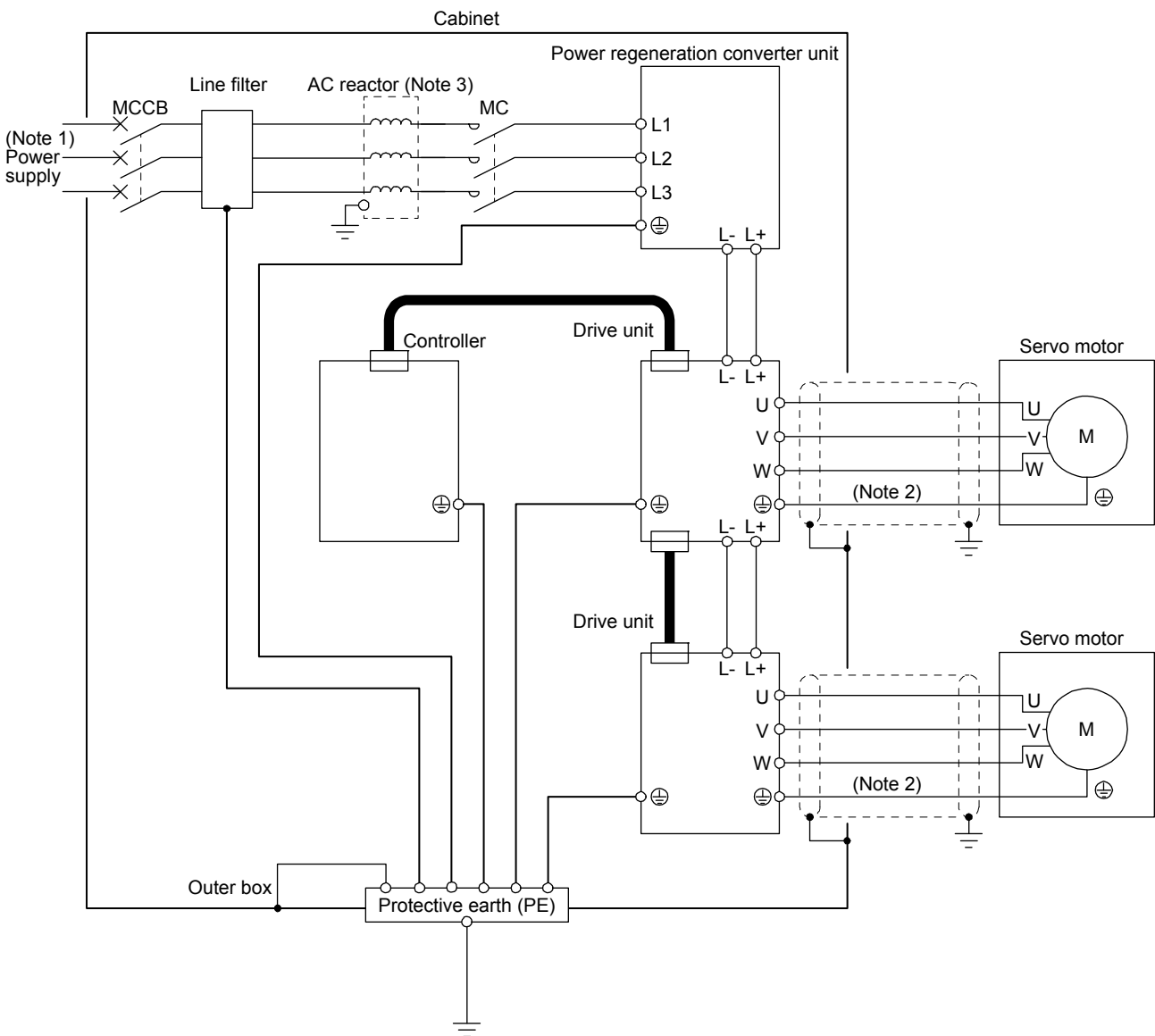

- Note 1. For the power supply specifications, refer to section 1.4.
- Note 2. Be sure to connect the grounding terminal of the servo motor to the PE terminal of the drive unit. Do not connect the wire directly to the protective earth of the cabinet.
- Note 3. Be sure to install an MR-AL-_AC reactor.

3. MR-CV_ POWER REGENERATION CONVERTER UNIT

3.4 Startup

 WARNING	<ul style="list-style-type: none"> ● When executing a test run, follow the notice and procedures in this instruction manual. Otherwise, it may cause a malfunction, damage to the machine, or injury. ● Do not operate switches with wet hands. Otherwise, it may cause an electric shock.
--	--

 CAUTION	<ul style="list-style-type: none"> ● Before starting operation, check the parameters. Improper settings may cause some machines to operate unexpectedly. ● The heat sink of the power regeneration converter unit and drive unit, and the servo motor, etc. may be hot while power is on and for some time after power-off. Take safety measures such as providing covers to avoid accidentally touching them by hands and parts such as cables. ● During operation, never touch the rotor of the servo motor. Otherwise, it may cause injury. ● Before wiring, switch operation, etc., eliminate static electricity. Otherwise, it may cause a malfunction.
--	--

The following items are the same as those for MR-J4-_-(-RJ). Refer to the section of the detailed explanation field for details. Read the corresponding section by replacing "servo amplifier" to "drive unit". "MR-J4-_B_" means "MR-J4-_B_-(-RJ) Servo Amplifier Instruction Manual".

Model	Item	Detailed explanation
MR-J4-DU_B_-(-RJ)	Switch setting and display of the servo amplifier	MR-J4-_B_ section 4.3
	Test operation	MR-J4-_B_ section 4.4
	Test operation mode	MR-J4-_B_ section 4.5

3. MR-CV_ POWER REGENERATION CONVERTER UNIT

3.4.1 Switching power on for the first time

When switching the power on for the first time, follow this section to startup.

"MR-J4-_B_" means "MR-J4-_B_(-RJ) Servo Amplifier Instruction Manual".

	Description	Reference
Wiring check	Check whether the power regeneration converter unit, the drive unit, and the servo motor are wired correctly by visual inspection, DO forced output function, etc.	(2) in this section
Surrounding environment check	Check the surrounding environment of the power regeneration converter unit, the drive unit and the servo motor.	MR-J4-_B_ Section 4.1.3
Axis No. settings	Confirm that the control axis No. set with the auxiliary axis number setting switches (SW2-3 and SW2-4) and with the converter setting rotary switch (SW1) match the control axis No. set with the servo system controller.	MR-J4-_B_ Section 4.3.1 (3) Section 3.4.3
Parameter setting	Set the parameters as necessary for the operation mode, etc.	Section 5.3
Test operation of the servo motor alone in test operation mode	For the test operation, with the servo motor disconnected from the machine and operated at the speed as low as possible, check whether the servo motor rotates correctly.	MR-J4-_B_ Section 4.5
Test operation of the servo motor alone by commands	For the test operation, give commands to the drive unit with the servo motor disconnected from the machine and operated at the speed as low as possible, check whether the servo motor rotates correctly.	
Test operation with the servo motor and machine connected	Connect the servo motor with the machine, and check machine motions by transmitting operation commands from the servo system controller.	
Gain adjustment	Make gain adjustment to optimize the machine motions.	MR-J4-_B_ Chapter 6
Actual operation		
Stop	Stop giving commands and stop operation.	

3. MR-CV_ POWER REGENERATION CONVERTER UNIT

(2) Wiring check

(a) Power supply system wiring

Before switching on the main circuit and control circuit power supplies, check the following items.

1) Power supply system wiring

- a) The power supplied to the power input terminals (L1/L2/L3/L11/L21) of the power regeneration converter unit and the power input terminals (L11/L21) of the drive unit should satisfy the defined specifications. (Refer to section 1.4.)
- b) When magnetic contactor drive output is enabled, the magnetic contactor control connector (CN23) should be connected to the coil of the magnetic contactor.

2) Connection of drive unit and servo motor

- a) The power outputs (U/V/W) of the drive unit should match in phase with the power inputs (U/V/W) of the servo motor.

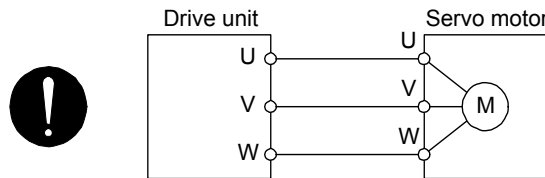

- b) The power supplied to the power regeneration converter unit should not be connected to the power outputs (U/V/W) of the drive unit. Otherwise, the drive unit and servo motor will fail.

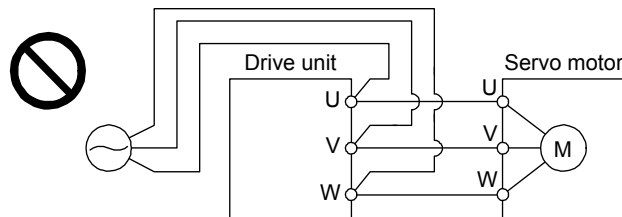

- c) The grounding terminal of the servo motor is connected to the PE terminal of the drive unit.

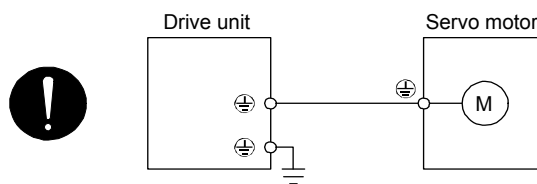

- 4) The CN2 connector of the drive unit should be connected to the encoder of the servo motor securely using the encoder cable.

3. MR-CV_ POWER REGENERATION CONVERTER UNIT

(b) I/O signal wiring

1) Power regeneration converter unit

- a) A voltage exceeding 24 V DC should not be applied to the pins of the CN24 connector.
- b) The wire between the plate and DOCOM of the CN24 connector should not be shorted.

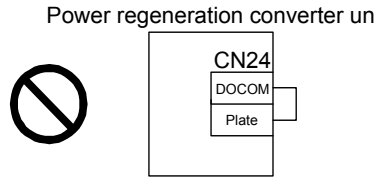

2) MR-J4-DU_B_(-RJ) drive unit

a) The I/O signals should be connected correctly.

Use DO forced output to forcibly turn on/off the pins of the CN3 connector. You can use this function to check the wiring. In this case, turn on the control circuit power supply only.

For details of I/O signal connection, refer to section 3.2 of "MR-J4-_B_(-RJ) Servo Amplifier Instruction Manual". For details of DO forced output, refer to section 4.5.1 of "MR-J4-_B_(-RJ) Servo Amplifier Instruction Manual".

- b) A voltage exceeding 24 V DC should not be applied to the pins of the CN3 connector.
- c) The plate and DOCOM of the CN3 connector should not be shorted.

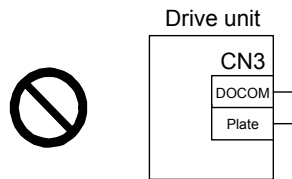

3. MR-CV_ POWER REGENERATION CONVERTER UNIT

3.4.2 Startup

(1) Power on

POINT
●Set [Pr. PA02] to "_7 __" for the drive unit which is connected to the power regeneration converter unit with the protection coordination cable.
●Set [Pr. PA02] to "4_ __" and [Pr. PF03] to "_1 __" for the drive unit which is not connected to the power regeneration converter unit with the protection coordination cable.
●Set [Pr. PF07] to "_1 __" to keep the main circuit power supply on at STO (when [AL. 95 occurs]).
●Set [Pr. PF07] "1_ __" to keep the main circuit power supply on when the forced stop is inputted (when [AL. E6 occurs]).
●For the drive unit which is not connected to the power regeneration converter unit with the protection coordination cable, make sure that the power regeneration converter unit is in ready-on state, and then turn on the servo-on with a command from the controller.

Startup of the MR-J4-DU_B_(-RJ) is the same as that of the MR-J4-_B_(-RJ). For details, refer to section 4.2 of "MR-J4-_B_(-RJ) Servo Amplifier Instruction Manual".

The power regeneration converter unit shows "C" (ready-off) on the display at power-on.

When an error occurs or EM1 (Forced stop) is disabled in the power regeneration converter unit, the operation will stop.

3. MR-CV_ POWER REGENERATION CONVERTER UNIT

3.4.3 Switch setting and operation section of power regeneration converter unit

Forced stop, protection coordination, and magnetic contactor drive output can be set with the switch on the power regeneration converter unit.

The 1-digit, 7-segment LED display shows the power regeneration converter unit status and the alarm number.

(1) Switches

 WARNING	<ul style="list-style-type: none"> ● Use an insulated screw driver for the converter setting rotary switch (SW1). Do not use a metal screw driver. Touching patterns on electronic boards, lead of electronic parts, etc. may cause an electric shock.
--	---

POINT	<ul style="list-style-type: none"> ● Do not set any values other than described to the converter setting rotary switch (SW1). ● The setting of the switch will be enabled after the main circuit power supply and control circuit power supply are cycled.
--------------	--

Set the converter setting rotary switch to enable/disable the forced stop, protection coordination, and magnetic contactor drive output. The following shows the setting of the converter setting rotary switch and a combination of enabling/disabling each function.

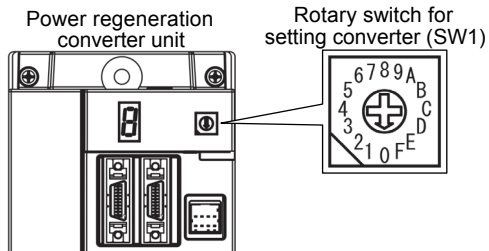

No.	Forced stop	Protection coordination		Magnetic contactor drive output
		Protection coordination	Stand-alone drive	
0 (initial value)	Disabled	Enabled	Disabled	Enabled
1	Disabled	Enabled	Disabled	Disabled
4	Enabled	Enabled	Disabled	Enabled
8	Disabled	Disabled	Enabled	Disabled
Other than above	Not used			

3. MR-CV_ POWER REGENERATION CONVERTER UNIT

(2) Scrolling display

(a) Normal display

When the control section of the power regeneration converter unit is turned on, the 1-digit, 7-segment LED display shows the progress of the initial setting. In normal operation, the 1-digit, 7-segment LED is always on.

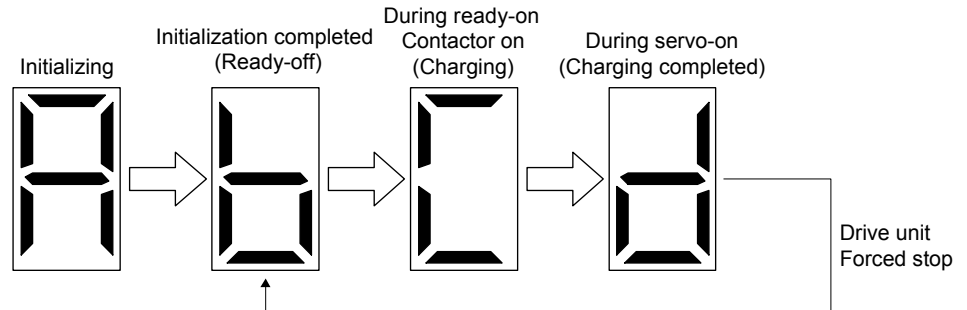

(b) Alarm display

When an alarm or warning occurs, each digit of the corresponding number is alternately displayed by blinking.

1) Displaying 2-digit number

Each of the two digits of the alarm or warning No. and blank are repeatedly displayed. The following shows when [AL. 61] is occurring as an example.

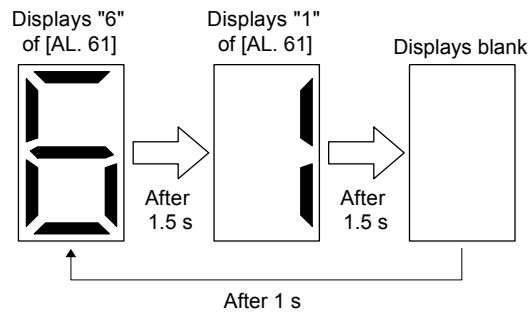

2) Displaying 3-digit number

Each of the three digits of the alarm or warning No. and blank are repeatedly displayed. The following shows when [AL. 6E.1] is occurring as an example.

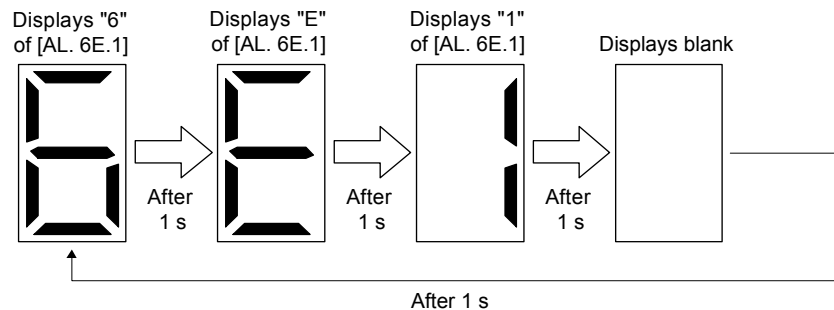

3. MR-CV_ POWER REGENERATION CONVERTER UNIT

(3) Display sequence

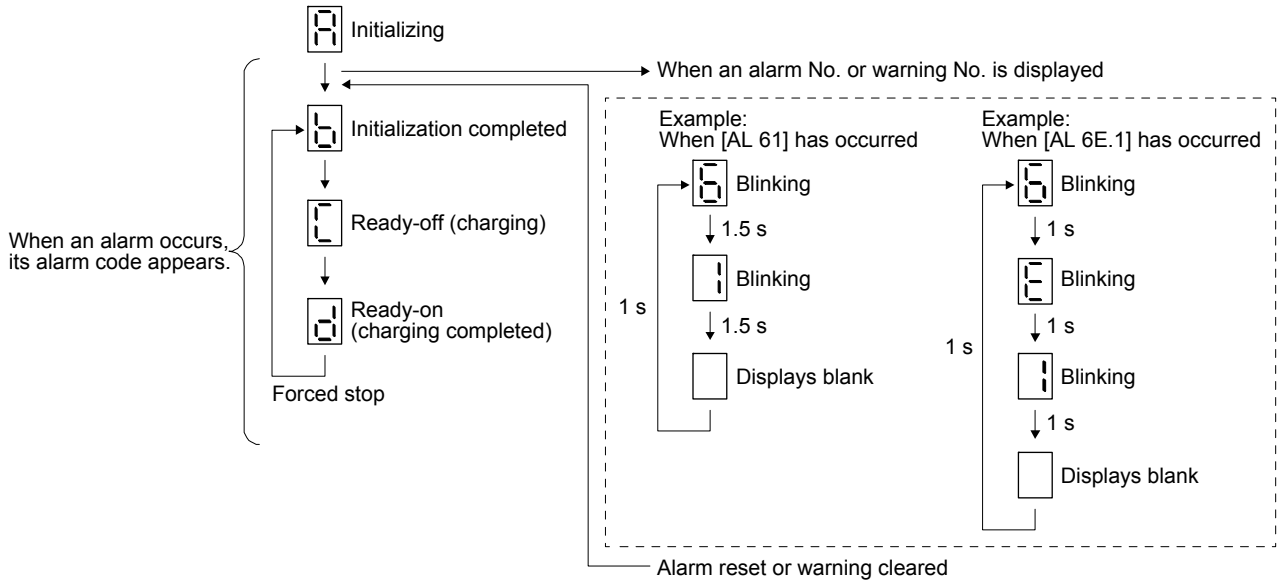

(4) Display transition of the power regeneration converter unit/MR-J4-DU_B_(-RJ) drive unit

The following shows the display transition of the power regeneration converter unit in which a protection coordination is enabled and MR-J4-DU_B_(-RJ) drive unit.

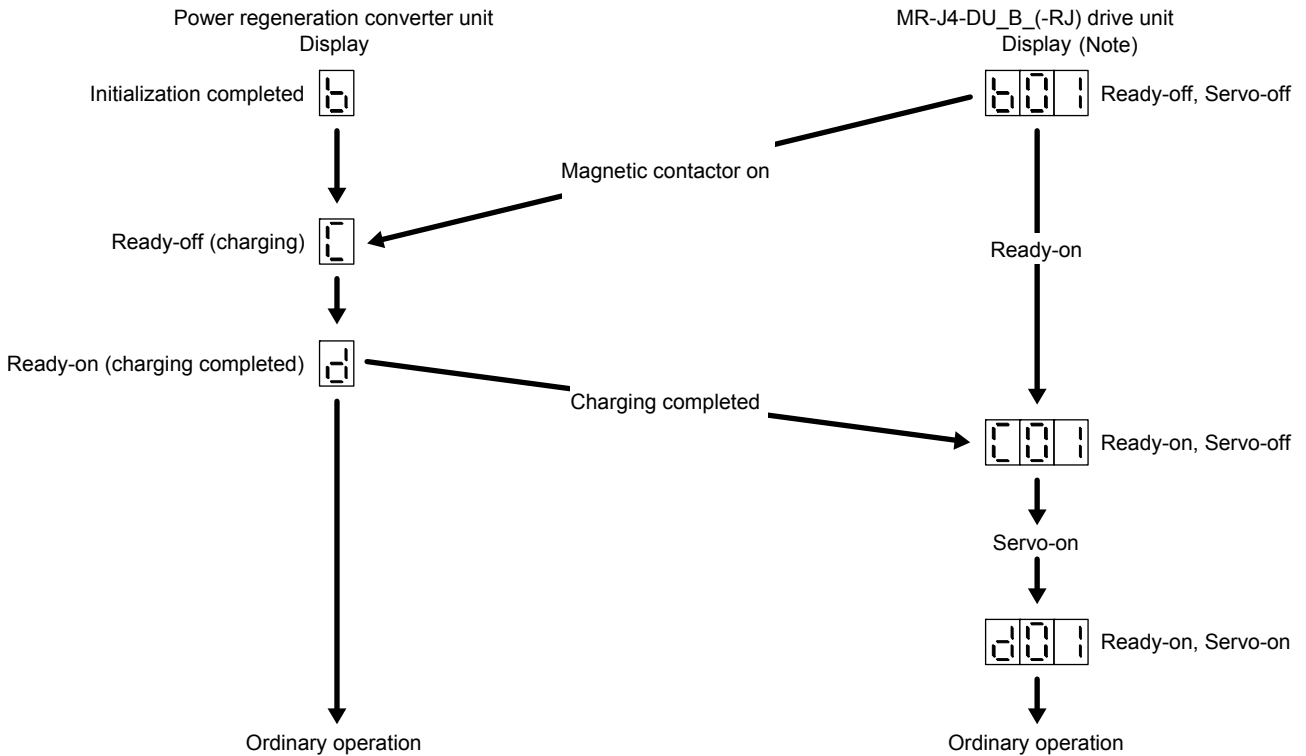

Note. For the detailed display transition of the drive unit, refer to "MR-J4-_B_(-RJ) Servo Amplifier Instruction Manual".

3. MR-CV_ POWER REGENERATION CONVERTER UNIT

(5) Status display list

The following table lists the power regeneration converter unit statuses.

Display	Status	Description
A stylized seven-segment display showing the letter 'a'.	Initializing	Displays during initialization.
A stylized seven-segment display showing the letter 'b'.	Initialization completed	Displays when initialization is complete, or during ready-off or servo-off.
A stylized seven-segment display showing the letter 'c'.	Ready-off (charging)	Displays in servo-off.
A stylized seven-segment display showing the letter 'd'.	Ready-on (charging completed)	Displays in servo-off.
(Note) A stylized seven-segment display showing an asterisk symbol.	Alarm and warning	The alarm No. and the warning No. that occurred are displayed.

Note. "*" indicates the alarm No. and the warning No.

3. MR-CV_ POWER REGENERATION CONVERTER UNIT

3.5 Characteristics

3.5.1 Overload protection characteristics

An electronic thermal is built in the power regeneration converter unit to protect the unit from overloads.

[AL. 7E Overload 1] occurs if overload operation above the electronic thermal protection curve shown in this section is performed. [AL. 7F Overload 2] occurs if the operation is continued exceeding the rated speed and rated torque. Use the unit on the left-side area of the graph.

The following table shows combinations of each power regeneration converter unit and graph of overload protection characteristics.

Power regeneration converter unit	Graph of overload protection characteristics
MR-CV11K MR-CV30K MR-CV37K MR-CV45K MR-CV11K4 MR-CV30K4 MR-CV37K4 MR-CV45K4	Characteristics A
MR-CV18K MR-CV18K4	Characteristics B
MR-CV55K	Characteristics C
MR-CV55K4 MR-CV75K4	Characteristics D

3. MR-CV_ POWER REGENERATION CONVERTER UNIT

(1) Characteristics A

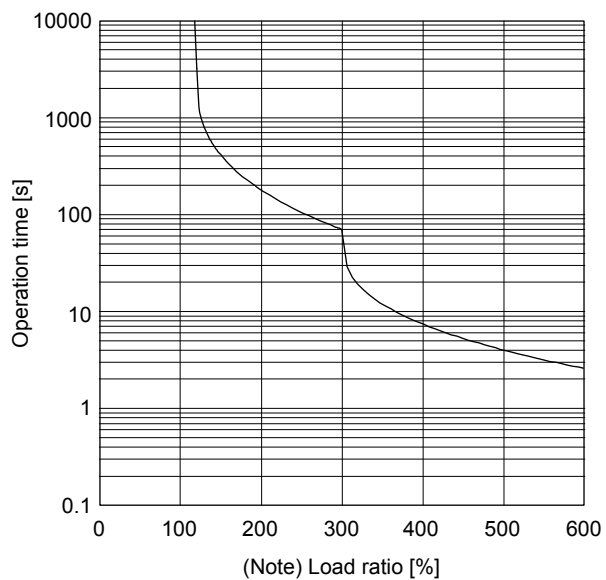

Note. Load ratio 100% indicates the continuous rating of the converter unit.

(2) Characteristics B

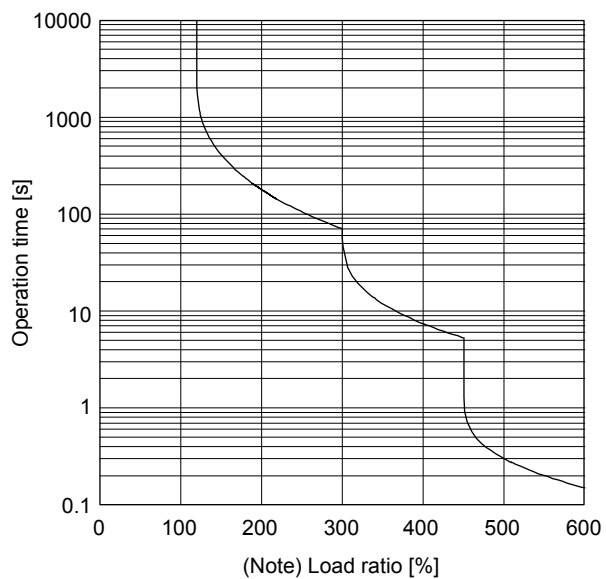

Note. Load ratio 100% indicates the continuous rating of the converter unit.

3. MR-CV_ POWER REGENERATION CONVERTER UNIT

(3) Characteristics C

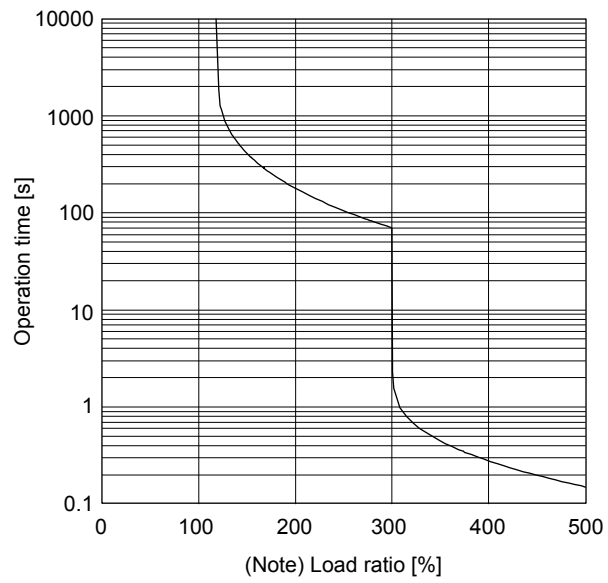

Note. Load ratio 100% indicates the continuous rating of the converter unit.

(4) Characteristics D

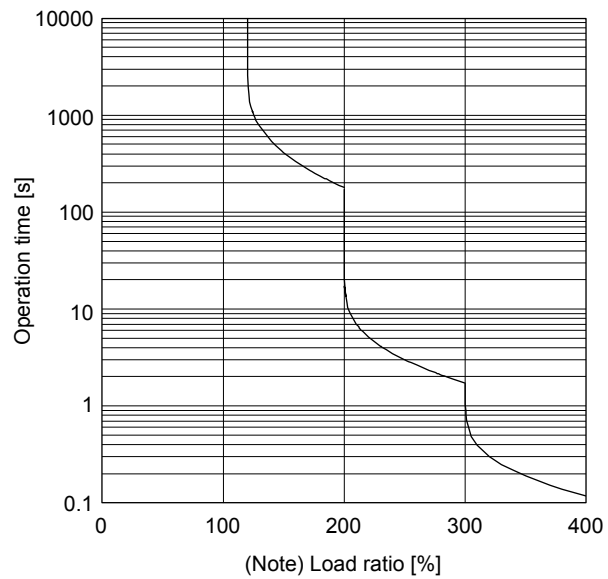

Note. Load ratio 100% indicates the continuous rating of the converter unit.

3. MR-CV_ POWER REGENERATION CONVERTER UNIT

3.5.2 Power supply capacity and generated loss

(1) Generated heat of the power regeneration converter unit and drive unit

The following tables indicate the generated loss under rated load and the power supply capacity per combination of the power regeneration converter unit and drive unit.

Power regeneration converter unit	Power supply capacity [kVA]	Generated heat of power regeneration converter unit [W]			Area required for heat dissipation [m ²]
		At rated output	At rated output (Generated heat in the cabinet when cooled outside the cabinet)	With servo-off	
MR-CV11K	16	124	25	25	2.5
MR-CV18K	27	193	32	25	3.9
MR-CV30K	43	317	45	25	6.4
MR-CV37K	53	396	53	25	8.0
MR-CV45K	64	496	104	25	10.0
MR-CV55K	78	595	164	30	12.0
MR-CV11K4	16	124	25	25	2.5
MR-CV18K4	27	193	32	25	3.9
MR-CV30K4	43	317	45	25	6.4
MR-CV37K4	53	402	53	25	8.1
MR-CV45K4	64	496	104	25	10.0
MR-CV55K4	78	596	164	30	12.0
MR-CV75K4	107	842	228	30	16.9

3. MR-CV_ POWER REGENERATION CONVERTER UNIT

Drive unit	Generated heat of drive unit [W]			Area required for heat dissipation [m ²]
	At rated output	At rated output (Generated heat in the cabinet when cooled outside the cabinet)	With servo-off	
MR-J4-DU900B(-RJ)	366	81	30	7.4
MR-J4-DU11KB(-RJ)	409	81	30	8.2
MR-J4-DU15KB(-RJ)	566	105	30	11.4
MR-J4-DU22KB(-RJ)	755	105	30	15.1
MR-J4-DU30KB(-RJ)	900	132	30	18.0
MR-J4-DU37KB(-RJ)	1000	132	30	20.0
MR-J4-DU900B4(-RJ)	366	81	30	7.4
MR-J4-DU11KB4(-RJ)	409	81	30	8.2
MR-J4-DU15KB4(-RJ)	566	105	30	11.4
MR-J4-DU22KB4(-RJ)	755	105	30	15.1
MR-J4-DU30KB4(-RJ)	790	132	30	15.8
MR-J4-DU37KB4(-RJ)	910	132	30	18.2
MR-J4-DU45KB4(-RJ)	1110	216	30	22.2
MR-J4-DU55KB4(-RJ)	1440	216	30	28.8

Even when multiple drive units and servo amplifiers are connected to one power regeneration converter unit, calculate the power supply capacity from the power regeneration converter unit capacity. The power supply capacity will be lower than the listed values when the total output wattage of the servo motors driven by the drive units and servo amplifiers connected to the power regeneration converter unit is lower than the converter capacity.

The servo motor requires 2 times to 2.5 times greater instantaneous power for acceleration, and therefore, use the power supply which ensures that the voltage lies within the permissible voltage fluctuation at the main circuit power supply terminals (L1/L2/L3) of the power regeneration converter unit. The power supply capacity will vary according to the power supply impedance.

The actual generated heat falls within the ranges at rated output and at servo-off according to the frequencies of use during operation. When designing an enclosed cabinet, use the values in the table, considering the worst operating conditions.

3. MR-CV_ POWER REGENERATION CONVERTER UNIT

(2) Heat dissipation area for an enclosed type cabinet

The enclosed type cabinet (hereafter called the cabinet) which will contain the power regeneration converter unit and drive unit should be designed to ensure that its temperature rise is within +10 °C at the ambient temperature of 40 °C. (allowing a margin of approximately 5 °C for the ambient temperature of 55 °C maximum) The necessary cabinet heat dissipation area can be calculated by next equation.

$$A = \frac{P}{K \cdot \Delta T}$$

A: Heat dissipation area [m²]

P: Loss generated in the cabinet [W]

ΔT: Difference between internal and ambient temperatures [°C]

K: Heat dissipation coefficient [5 to 6]

When calculating the heat dissipation area with the equation, assume that P is the sum of all losses generated in the cabinet. Refer to (1) in this section for the generated heat of the power regeneration converter unit and drive unit. "A" indicates the effective area for heat dissipation, but if the cabinet is directly installed on an insulated wall, that extra amount must be added to the cabinet's surface area. The required heat dissipation area will vary with the conditions in the cabinet. If convection in the cabinet is poor and heat builds up, effective heat dissipation will not be possible. Therefore, arrangement of the equipment in the cabinet and the use of a cooling fan should be considered. The above (1) in this section lists the cabinet dissipation area (guideline) when this unit and drive unit are operated at the ambient temperature of 40 °C under rated load.

When air flows along the outer wall of the cabinet, effective heat exchange will be possible, because the temperature slope inside and outside the cabinet will be steeper.

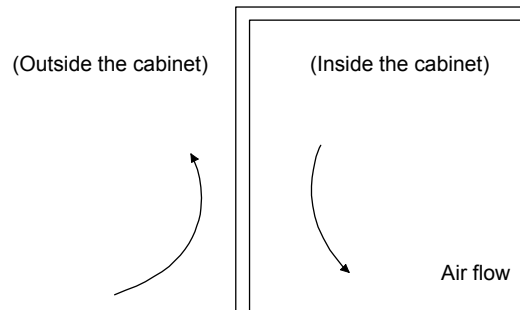

3. MR-CV_ POWER REGENERATION CONVERTER UNIT

3.5.3 Inrush currents at power-on of the main circuit and control circuit power supplies

Since large inrush currents flow in the power supplies, be sure to use molded-case circuit breakers and magnetic contactors. (Refer to section 8.5.)

When circuit protectors are used, it is recommended that the inertia delay type, which is not tripped by an inrush current, be used.

(1) 200 V class

The following table indicates the inrush currents (reference data) that will flow when 240 V AC is applied.

Power regeneration converter unit	Inrush currents (A _{0-P})	
	Main circuit power supply (L1/L2/L3)	Control circuit power supply (L11/L21)
MR-CV11K	38 A (attenuated to approx. 10 A in 45 ms)	23 A (attenuated to approx. 2 A in 5 ms)
MR-CV18K	38 A (attenuated to approx. 10 A in 70 ms)	
MR-CV30K	81 A (attenuated to approx. 20 A in 65 ms)	
MR-CV37K	81 A (attenuated to approx. 20 A in 86 ms)	
MR-CV45K		
MR-CV55K	57 A (attenuated to approx. 20 A in 137 ms)	

(2) 400 V class

The following table indicates the inrush currents (reference data) that will flow when 480 V AC is applied.

Power regeneration converter unit	Inrush currents (A _{0-P})	
	Main circuit power supply (L1/L2/L3)	Control circuit power supply (L11/L21)
MR-CV11K4	24 A (attenuated to approx. 10 A in 22 ms)	15 A (attenuated to approx. 2 A in 5 ms)
MR-CV18K4	24 A (attenuated to approx. 10 A in 35 ms)	
MR-CV30K4	48 A (attenuated to approx. 20 A in 35 ms)	
MR-CV37K4	48 A (attenuated to approx. 20 A in 45 ms)	
MR-CV45K4		
MR-CV55K4	42 A (attenuated to approx. 20 A in 66 ms)	15 A (attenuated to approx. 2 A in 7 ms)
MR-CV75K4		

3. MR-CV_ POWER REGENERATION CONVERTER UNIT

3.6 Disabling the protection coordination mode (stand-alone drive)

CAUTION

- Do not supply power to the main circuit power supply terminals (L1/L2/L3) of the servo amplifier. Otherwise, the servo amplifier and MR-CV_ power regeneration converter unit will malfunction.
- Connect the DC power supply between the MR-CV_ and servo amplifier with correct polarity. If incorrectly connected, the MR-CV_ and servo amplifier will malfunction.

POINT

- When using the servo amplifier (not the drive unit) with the MR-CV_, set the converter setting rotary switch (SW1) of the MR-CV_ to "8" to disable the protection coordination mode.
- Two or more MR-CV_ power regeneration converter units cannot be installed to improve regeneration capability. Do not connect multiple MR-CV_s in a same DC power supply line.
- When using the servo amplifier with MR-CV_, set [Pr. PA04] of the servo amplifier to "0 0 _ _" to enable EM1 (Forced stop 1).
- In this configuration, only the STO function is supported. The forced stop deceleration function is not available.
- When using the power regeneration converter unit, set [Pr. PA02] to "0001".

3. MR-CV_ POWER REGENERATION CONVERTER UNIT

3.6.1 200 V class

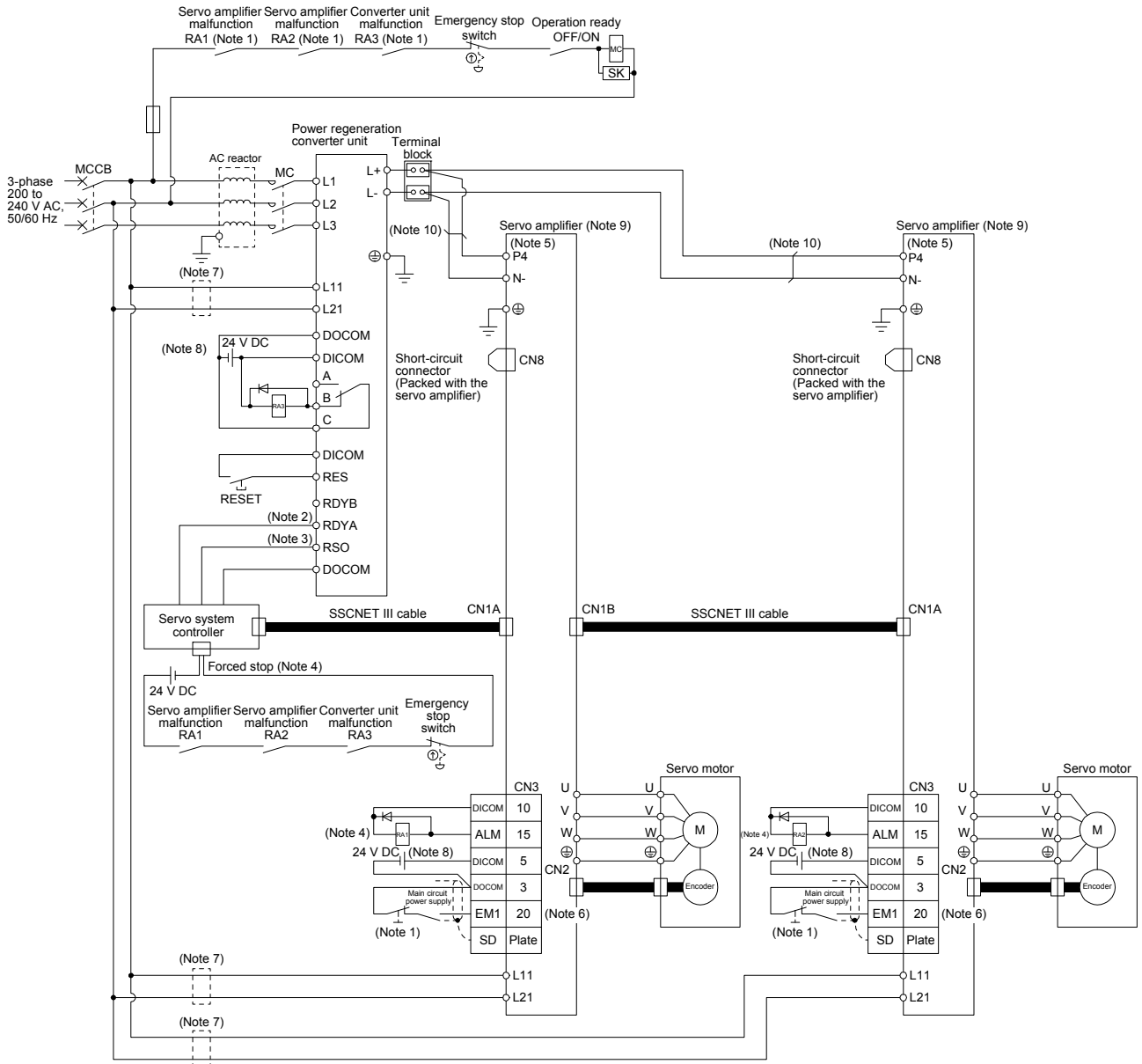

3. MR-CV_ POWER REGENERATION CONVERTER UNIT

Note 1. Configure a sequence that will shut off the main circuit power when:

- An alarm has occurred at FR-CV or servo amplifier.
- EM1 (Forced stop 1) is enabled.

After MR-CV_ is in ready-on state, if the main circuit power supply for MR-CV_ is shut-off, alarms monitoring the power supply ([AL. 62 Frequency error], [AL. 67 open-phase], or [AL. 71 Undervoltage]) will occur. Remove what cause the main circuit power supply of MR-CV_ to shut off and cycle the power.

2. For the servo amplifier, configure a sequence that will switch the servo-on after the MR-CV_ is ready.
3. The RSO signal turns off when the reset signal is inputted and MR-CV_ is ready for operation. Configure a sequence that will make the servo inoperative when the RSO signal is on.
4. Configure a sequence that will stop the MR-CV_ with the emergency stop input from the servo system controller if an alarm occurs in the MR-CV_. When the servo system controller does not have an emergency stop input, use the forced stop input of the servo amplifier to make a stop as shown in the diagram.
5. When using MR-CV_, be sure to disconnect wiring between P3 and P4 terminals.
6. Set [Pr. PA04] to "0 0 _ _" to enable EM1 (Forced stop 1).
7. Use a molded-case circuit breaker to L11 and L21.
8. The illustration of the 24 V DC power supply is divided between input signal and output signal for convenience. However, they can be configured by one.
9. When using the servo amplifier of 7 kW or less, make sure to connect the built-in regenerative resistor. (factory-wired) (5 kW or less: P+ and D, 7 kW or less: P+ and C)
10. Twist or bundle the wires between L+/L- of the power regeneration converter unit and P4/N- of the servo amplifier with cable ties to keep the two wires close to each other. Keep the wiring length between L+/L- of the power regeneration converter unit and P4/N- of the servo amplifier 1.5 m or longer, and total wiring length 5 m or shorter.

3. MR-CV_ POWER REGENERATION CONVERTER UNIT

3.6.2 400 V class

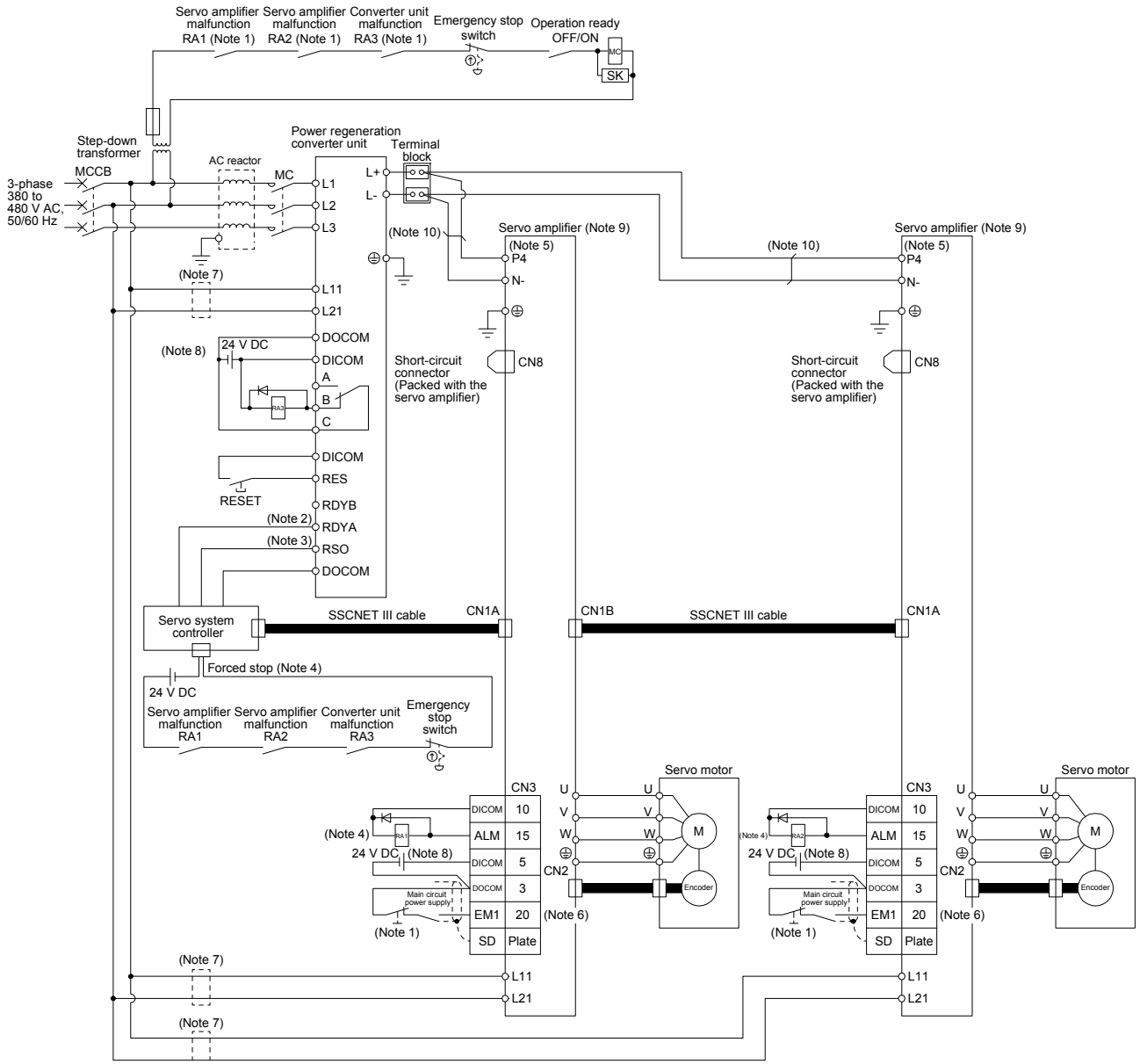

3. MR-CV_ POWER REGENERATION CONVERTER UNIT

Note 1. Configure a sequence that will shut off the main circuit power when:

- An alarm has occurred at FR-CV or servo amplifier.
- EM1 (Forced stop 1) is enabled.

After MR-CV_ is in ready-on state, if the main circuit power supply for MR-CV_ is shut-off, alarms monitoring the power supply ([AL. 62 Frequency error], [AL. 67 open-phase], or [AL. 71 Undervoltage]) will occur. Remove what cause the main circuit power supply of MR-CV_ to shut off and cycle the power.

2. For the servo amplifier, configure a sequence that will switch the servo-on after the MR-CV_ is ready.
3. The RSO signal turns off when the reset signal is inputted and MR-CV_ is ready for operation. Configure a sequence that will make the servo inoperative when the RSO signal is on.
4. Configure a sequence that will stop the MR-CV_ with the emergency stop input from the servo system controller if an alarm occurs in the MR-CV_. When the servo system controller does not have an emergency stop input, use the forced stop input of the servo amplifier to make a stop as shown in the diagram.
5. When using MR-CV_, be sure to disconnect wiring between P3 and P4 terminals.
6. Set [Pr. PA04] to "0 0 _ _" to enable EM1 (Forced stop 1).
7. Use a molded-case circuit breaker to L11 and L21.
8. The illustration of the 24 V DC power supply is divided between input signal and output signal for convenience. However, they can be configured by one.
9. When using the servo amplifier of 7 kW or less, make sure to connect the built-in regenerative resistor. (factory-wired) (3.5 kW or less: P+ and D, 7 kW or less: P+ and C)
10. Twist or bundle the wires between L+/L- of the power regeneration converter unit and P4/N- of the servo amplifier with cable ties to keep the two wires close to each other. Keep the wiring length between L+/L- of the power regeneration converter unit and P4/N- of the servo amplifier 1.5 m or longer, and total wiring length 5 m or shorter.

4. MR-CR_ RESISTANCE REGENERATION CONVERTER UNIT

4. MR-CR_ RESISTANCE REGENERATION CONVERTER UNIT

POINT	
●	MR-CR_ resistance regeneration converter unit can be used in a combination with MR-J4-DU_(-RJ) drive units of 30 kW or more.

4. MR-CR_ RESISTANCE REGENERATION CONVERTER UNIT

4.1 Function block diagram

(1) MR-J4-DU_B_(-RJ)

The function block diagram of this servo is shown below.

POINT

- The diagram shows the combination of the MR-J4-DU_B_-RJ drive unit and resistance regeneration converter unit as an example. The MR-J4-DU_B_ drive unit does not have the CN2L connector.

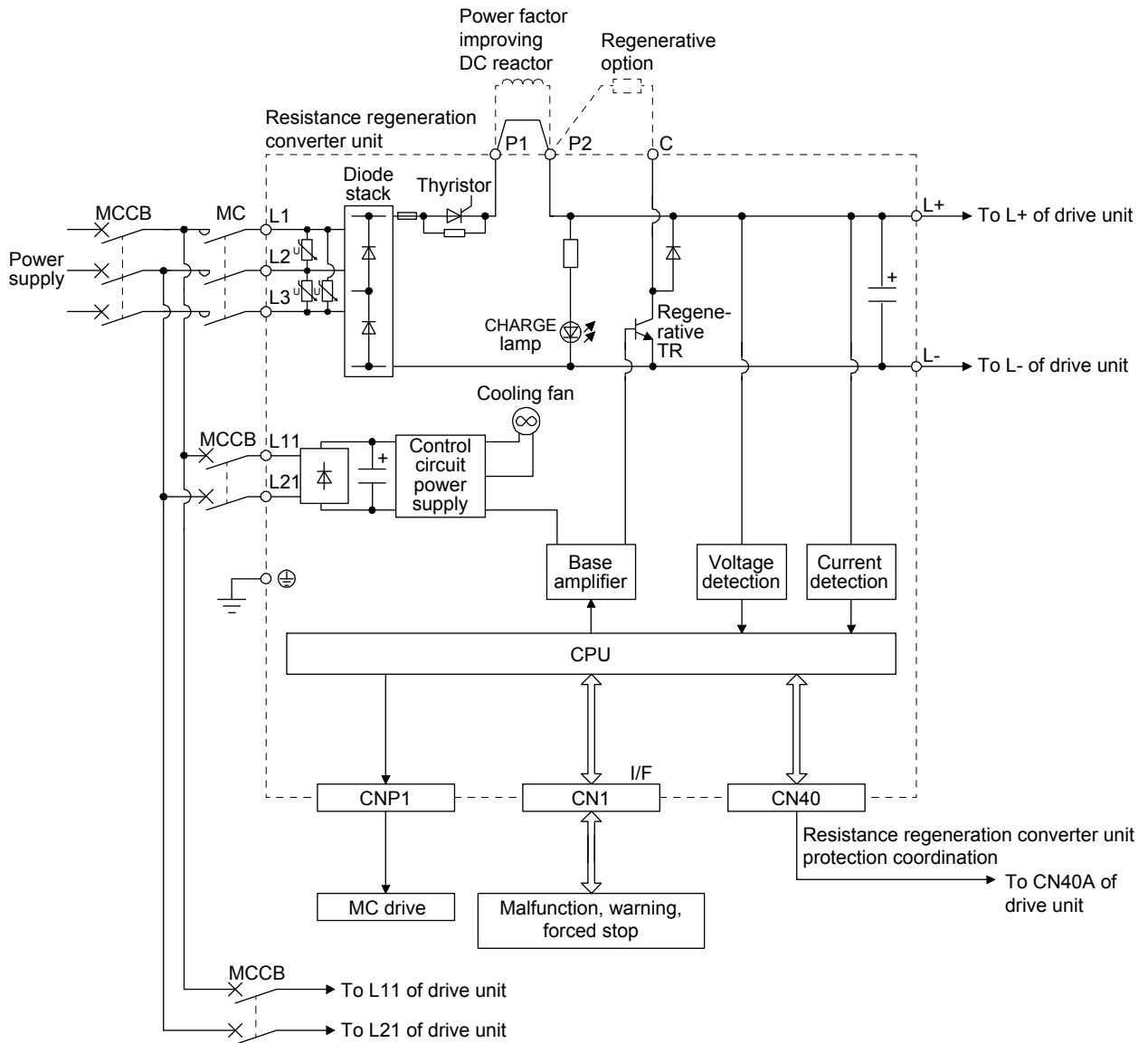

4. MR-CR_ RESISTANCE REGENERATION CONVERTER UNIT

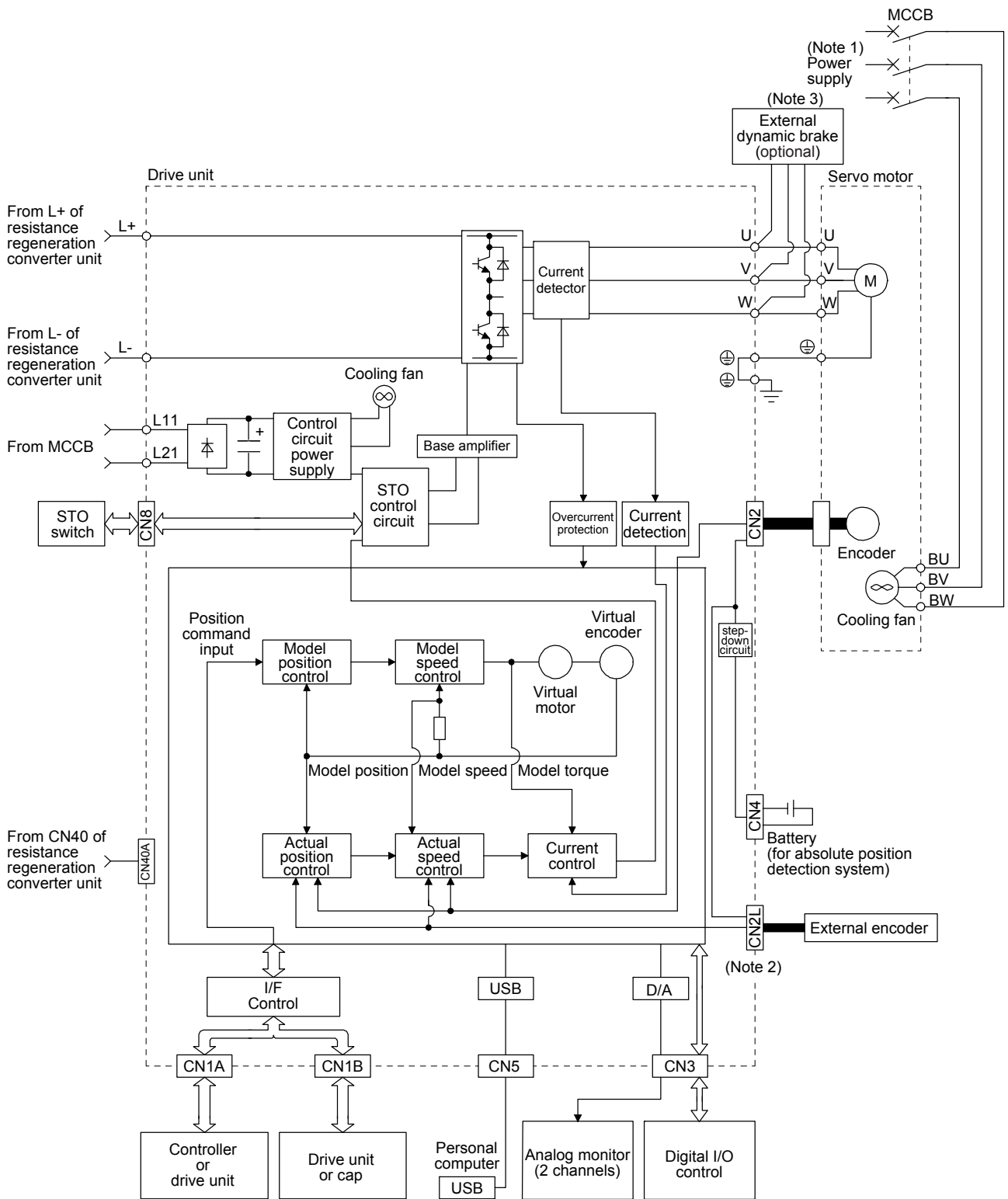

- Note 1. For specifications of the cooling fan power supply, refer to "Servo Motor Instruction Manual (Vol. 3)".
- Note 2. This is for the MR-J4-DU_B_-RJ drive unit. The MR-J4-DU_B_ drive unit does not have the CN2L connector.
- Note 3. Use an external dynamic brake for the drive unit. Failure to do so will cause an accident because the servo motor does not stop immediately but coasts at an alarm occurrence for which the servo motor does not decelerate to stop. Ensure the safety in the entire equipment. For wiring of the external dynamic brake, refer to section 8.3. For alarms for which the servo motor does not decelerate to stop, refer to chapter 6.

4. MR-CR_ RESISTANCE REGENERATION CONVERTER UNIT

(2) MR-J4-DU_A_(-RJ)

The function block diagram of this servo is shown below.

POINT

- The diagram shows the combination of the MR-J4-DU_A_-RJ drive unit and resistance regeneration converter unit as an example. The MR-J4-DU_A_ drive unit does not have the CN2L connector.

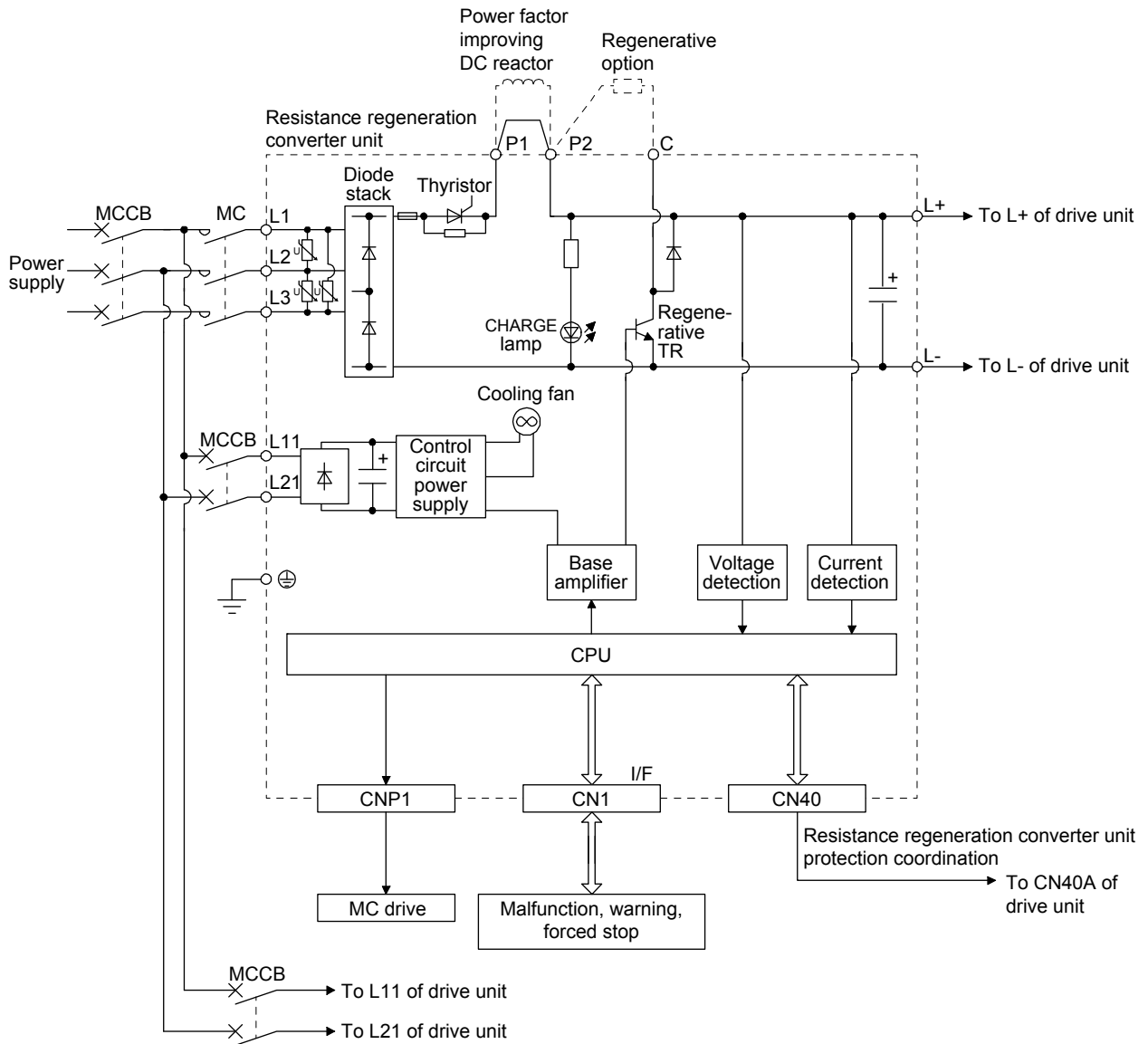

4. MR-CR_ RESISTANCE REGENERATION CONVERTER UNIT

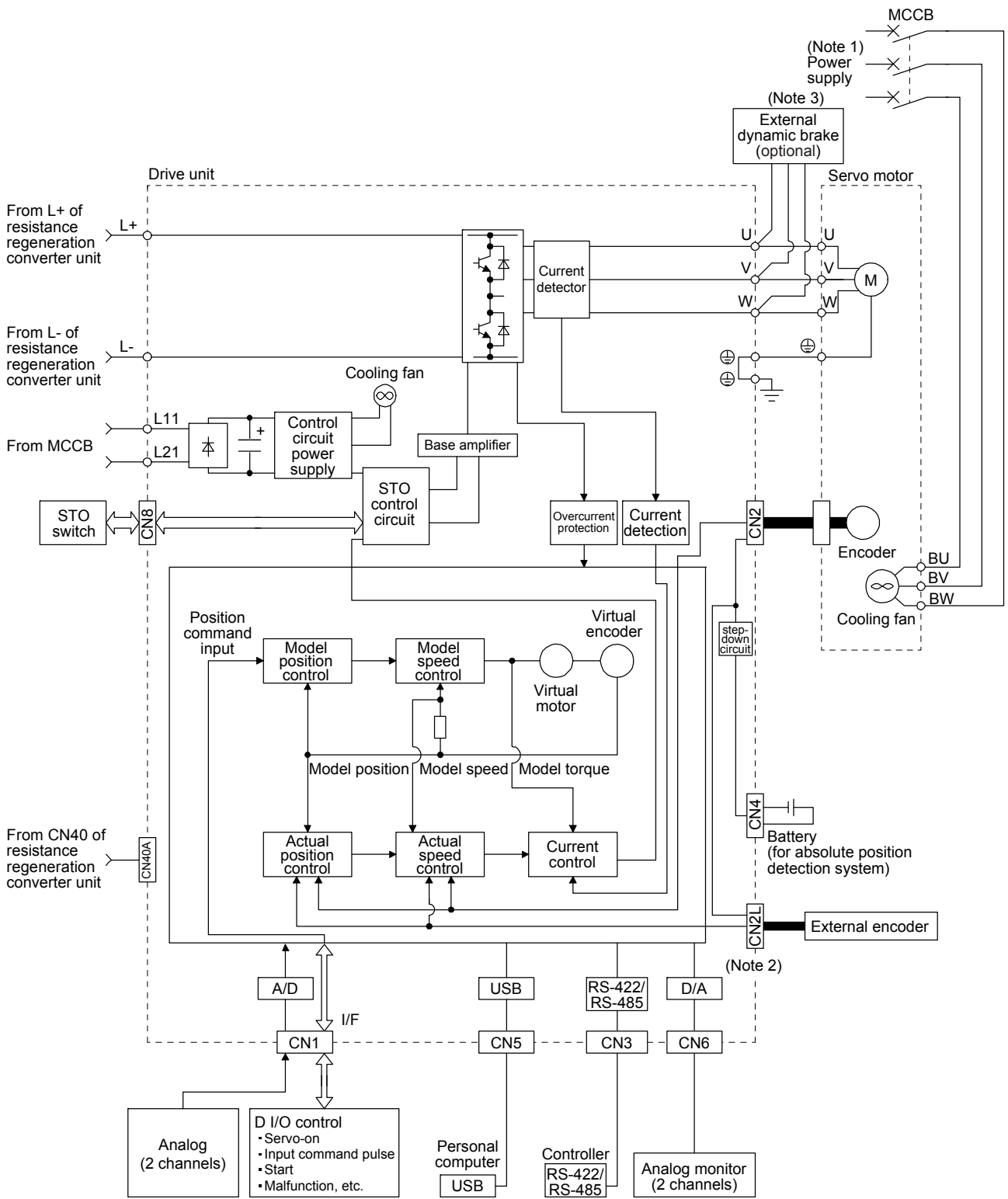

- Note 1. For specifications of the cooling fan power supply, refer to "Servo Motor Instruction Manual (Vol. 3)".
- Note 2. This is for the MR-J4-DU_A_-RJ drive unit. The MR-J4-DU_A_ drive unit does not have the CN2L connector.
- Note 3. Use an external dynamic brake for the drive unit. Failure to do so will cause an accident because the servo motor does not stop immediately but coasts at an alarm occurrence for which the servo motor does not decelerate to stop. Ensure the safety in the entire equipment. For wiring of the external dynamic brake, refer to section 8.3. For alarms for which the servo motor does not decelerate to stop, refer to chapter 6.

4. MR-CR_ RESISTANCE REGENERATION CONVERTER UNIT

4.2 Structure

4.2.1 Parts identification

POINT

● The resistance regeneration converter unit is shown with the terminal cover open. For opening or closing of the terminal cover, refer to section 4.2.2.

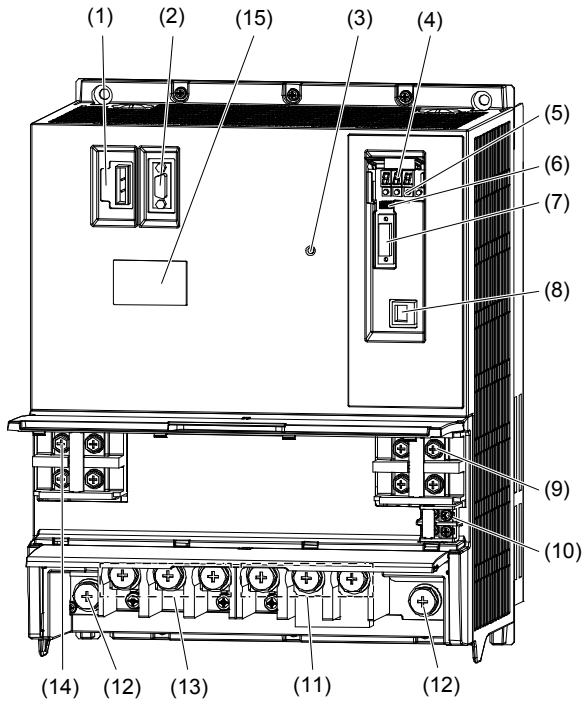

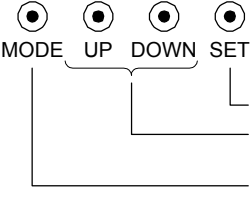
No.	Name/Application	Detailed explanation
(1)	Magnetic contactor control connector (CNP1) Used to connect the coil of the magnetic contactor.	Section 4.3.3
(2)	I/O signal connector (CN1) Used to connect digital I/O signals.	
(3)	Charge lamp Lights up when the main circuit is charged. While this lamp is lit, do not reconnect the cables.	
(4)	Display The 3-digit, 7-segment LED display shows the resistance regeneration converter unit status and the alarm number.	
(5)	Operation section Used to perform status display, diagnostic, alarm, and parameter setting operations. 	Section 4.4.3
(6)	Manufacturer setting connector (CN6) This is for manufacturer setting. Although the shape is similar to the analog monitor connector (CN6) of the drive unit, do not connect anything including an analog monitor.	
(7)	Protection coordination connector (CN40) Used to connect CN40A of the drive unit.	
(8)	Manufacturer setting connector (CN3) This is for manufacturer setting. Although the shape is similar to the RS-422/RS-485 communication connector (CN3) of the drive unit, do not connect anything, including a personal computer and parameter unit.	
(9)	L+/L- terminal (TE2-2) Used to connect a drive unit using a bus bar supplied with the drive unit.	
(10)	Control circuit terminal L11 and L21 (TE3) Used to connect the control circuit power supply.	Section 4.3.1 Section 4.3.2
(11)	Regenerative option/Power factor improving DC reactor (TE1-2) Used to connect a regenerative option or a power factor improving DC reactor.	
(12)	Protective earth (PE) terminal Grounding terminal	
(13)	Main circuit terminal block (TE1-1) Used to connect the input power supply.	Section 8.11
(14)	L+/L- terminal (TE2-1) When using a brake unit, connect it to this terminal. Do not connect anything other than the brake unit.	
(15)	Rating plate	Section 1.2

4. MR-CR_ RESISTANCE REGENERATION CONVERTER UNIT

4.2.2 Opening and closing of the terminal block cover



WARNING

● Before opening or closing the terminal block cover, turn off the power and wait for 20 minutes or more until the charge lamp turns off. Then, confirm that the voltage between L+ and L- is safe with a voltage tester or others. Otherwise, an electric shock may occur. In addition, always confirm that the charge lamp is off from the front of the resistance regeneration converter unit.

The following shows how to open and close the terminal block cover using illustrations of resistance regeneration converter unit as an example. For a drive unit, the shape of the main unit is different. However, the terminal block cover can be opened or closed in the same procedure.

- (1) Upper terminal block cover
(a) How to open

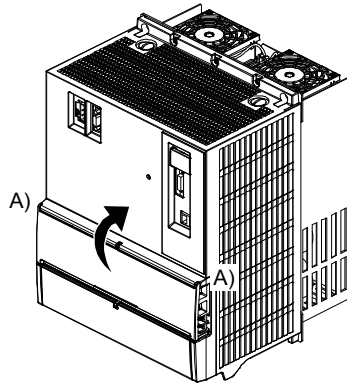

- 1) Pull up the cover using point A) as a support.

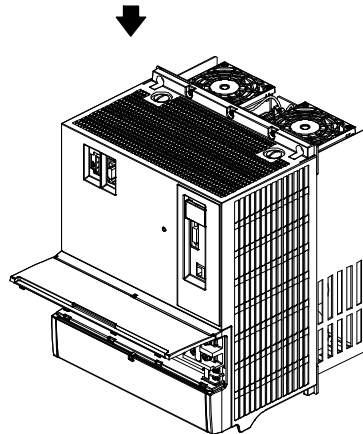

- 2) The cover is fixed when pulled up to the position as shown in the illustration.

4. MR-CR_ RESISTANCE REGENERATION CONVERTER UNIT

(b) How to close

1) Close the cover using point A) as a support.

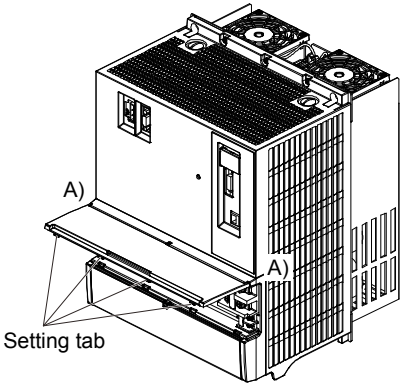

2) Press the cover against the terminal box until the installing knobs click.

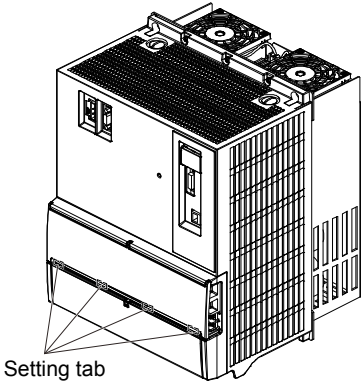

4. MR-CR_ RESISTANCE REGENERATION CONVERTER UNIT

- (2) Lower terminal block cover
(a) How to open

1) Hold the bottom of the terminal block cover with both hands.

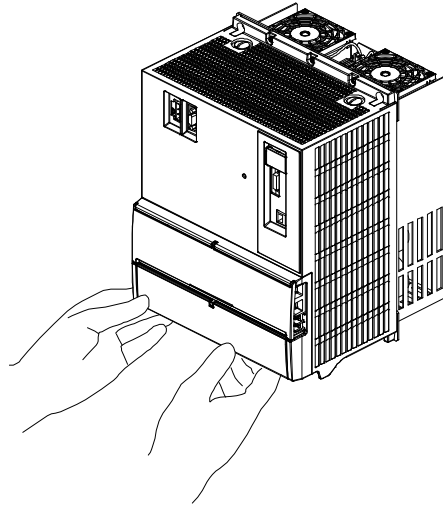

2) Pull up the cover using point B) as a support.

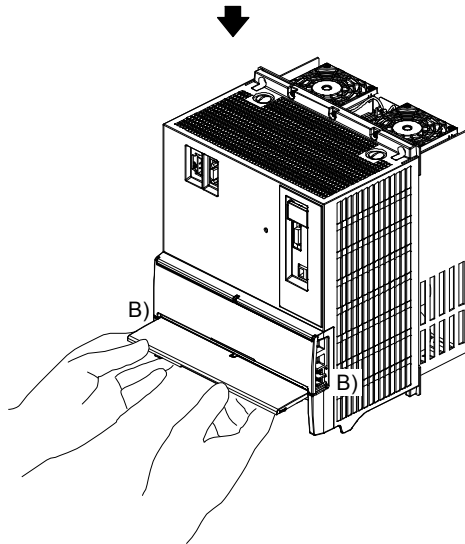

3) The cover is fixed when pulled up to the top.

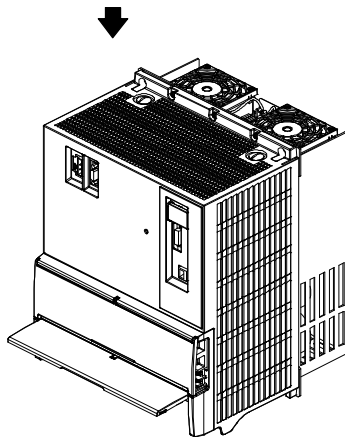

4. MR-CR_ RESISTANCE REGENERATION CONVERTER UNIT

(b) How to close

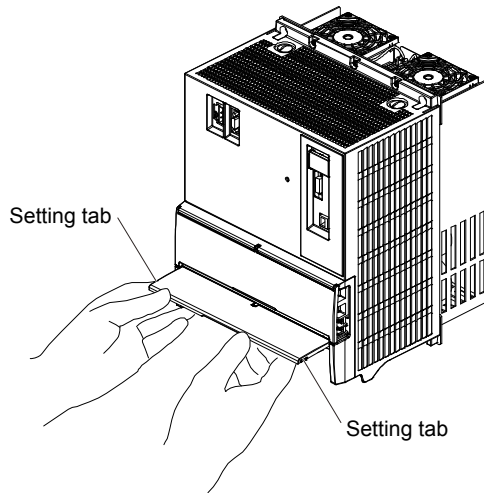

1) Hold the bottom of the terminal block cover with both hands.

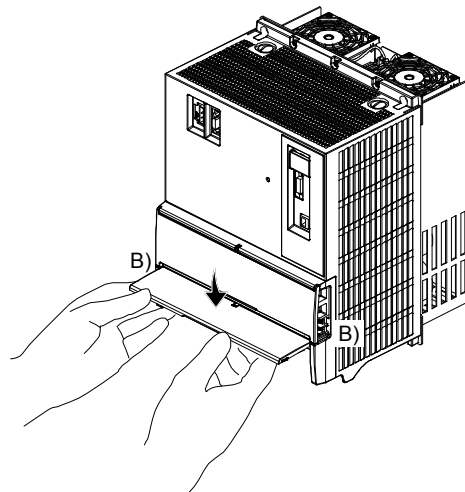

2) Close the cover using point B) as a support.

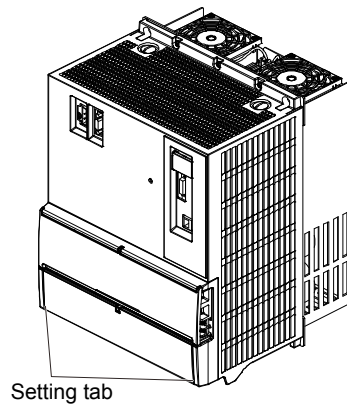

3) Press the cover against the terminal box until the installing knobs click.

4. MR-CR_ RESISTANCE REGENERATION CONVERTER UNIT

4.3 Signals and wiring

⚠ WARNING

- A person who is involved in wiring should be fully competent to do the work.
- Before wiring, turn off the power and wait for 15 minutes or more until the charge lamp turns off. Then, confirm that the voltage between L+ and L- is safe with a voltage tester or others. Otherwise, an electric shock may occur. In addition, always confirm that the charge lamp is off from the front of the resistance regeneration converter unit.
- Ground the resistance regeneration converter unit, the drive unit and the servo motor securely.
- Do not attempt to wire the resistance regeneration converter unit, the drive unit, and the servo motor until they have been installed. Otherwise, it may cause an electric shock.
- The cables should not be damaged, stressed, loaded, or pinched. Otherwise, it may cause an electric shock.
- To avoid an electric shock, insulate the connections of the power supply terminals.

⚠ CAUTION

- Wire the equipment correctly and securely. Otherwise, the servo motor may operate unexpectedly, resulting in injury.
- Connect cables to the correct terminals. Otherwise, a burst, damage, etc. may occur.
- Ensure that polarity (+/-) is correct. Otherwise, a burst, damage, etc. may occur.
- The surge absorbing diode installed to the DC relay for control output should be fitted in the specified direction. Otherwise, the emergency stop and other protective circuits may not operate.

Resistance regeneration converter unit

DOCOM

Control output signal

24 V DC

RA

For sink output interface

Resistance regeneration converter unit

DOCOM

Control output signal

24 V DC

RA

For source output interface

- Use a noise filter, etc. to minimize the influence of electromagnetic interference. Electromagnetic interference may be given to the electronic equipment used near the resistance regeneration converter unit and the drive unit.
- When using the regenerative resistor, switch power off with the alarm signal. Otherwise, a transistor fault or the like may overheat the regenerative resistor, causing a fire.
- Do not modify the equipment.

4. MR-CR_ RESISTANCE REGENERATION CONVERTER UNIT

The following items are the same as those of MR-J4-_-(-RJ). For details of the items, refer to each chapter/section indicated in the detailed explanation field. "MR-J4-_B_" means "MR-J4-_B_(-RJ) Servo Amplifier Instruction Manual". "MR-J4-_A_" means "MR-J4-_A_(-RJ) Servo Amplifier Instruction Manual".

Model	Item	Detailed explanation
MR-J4-DU_B_(-RJ)	I/O signal connection example	MR-J4-_B_ section 3.2
	Forced stop deceleration function	MR-J4-_B_ section 3.6
	SSCNET III cable connection	MR-J4-_B_ section 3.9
MR-J4-DU_A_(-RJ)	I/O signal connection example	MR-J4-_A_ section 3.2
	Forced stop deceleration function	MR-J4-_A_ section 3.7

4.3.1 Input power supply circuit

⚠ WARNING

- Insulate the connections of the power supply terminals. Otherwise, an electric shock may occur.
- Always connect the magnetic contactor wiring connector to CNP1 of the resistance regeneration converter unit. If the connector is not connected, an electric shock may occur.

⚠ CAUTION

- Always connect the magnetic contactor between the power supply and the main circuit power supply (L1/L2/L3) of the resistance regeneration converter unit, in order to configure a circuit that shuts down the power supply on the side of the resistance regeneration converter unit power supply. If the magnetic contactor is not connected, a large current keeps flowing and may cause a fire when the resistance regeneration converter unit or the drive unit malfunctions.
- Use ALM (Malfunction) to switch power off. Not doing so may cause a fire when a regenerative transistor malfunctions or the like may overheat the regenerative resistor.
- The resistance regeneration converter unit has a built-in surge absorber (varistor) to reduce exogenous noise and to suppress lightning surge. Exogenous noise or lightning surge deteriorates the varistor characteristics, and the varistor may be damaged. To prevent a fire, use a molded-case circuit breaker or fuse for input power supply.
- Check the resistance regeneration converter unit model, and then input proper voltage to the resistance regeneration converter unit power supply. If input voltage exceeds the upper limit, the resistance regeneration converter unit and the drive unit will break down.

POINT

- For drive units, EM2 has the same function as EM1 in the torque control mode.
- For the MR-J4-DU_B_(-RJ) drive units, do not switch off the control circuit power supply even though an alarm occurs. When the control circuit power supply is switched off, optical module does not operate, and optical transmission of SSCNET III/H communication is interrupted. Therefore, the next axis servo amplifier and the drive unit display "AA" at the indicator and turn into base circuit shut-off. The dynamic brake operates, bringing the servo motor to a stop.

4. MR-CR_ RESISTANCE REGENERATION CONVERTER UNIT

(1) Magnetic contactor control connector (CNP1)



CAUTION

● Always connect the magnetic contactor wiring connector to the resistance regeneration converter unit. If the connector is not connected, an electric shock may occur since CNP1-1 and L11 are always conducting.

By enabling magnetic contactor drive output, the main circuit power supply can be shut off automatically when an alarm occurs in the resistance regeneration converter unit or the drive unit.

To enable magnetic contactor drive output, set [Pr. PA02] of the resistance regeneration converter unit to "___ 1" (initial value).

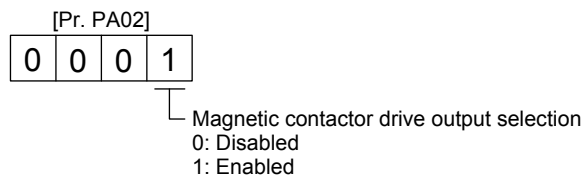

(a) When magnetic contactor drive output is enabled

To control the magnetic contactor, connect the magnetic contactor control connector (CNP1) to the coil of the magnetic contactor.

Internal connection diagram of CNP1

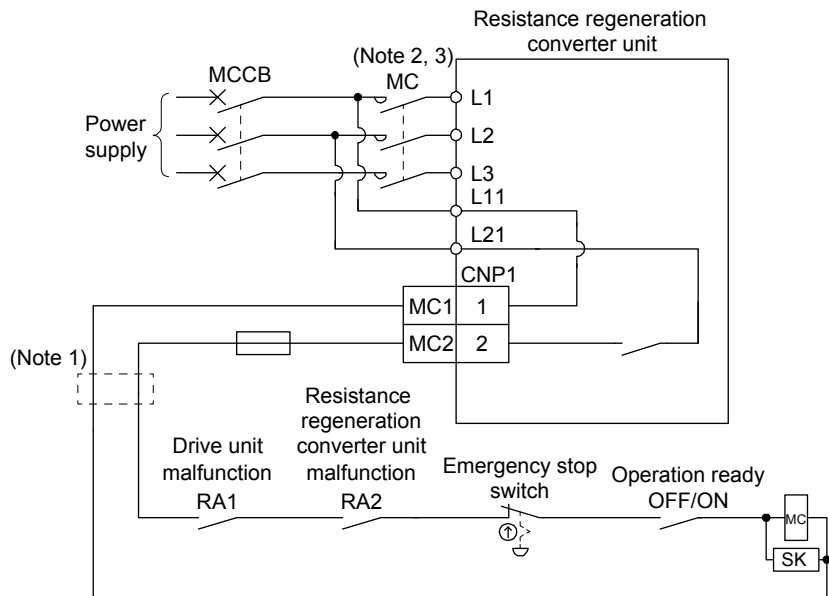

Note 1. A step-down transformer is required when coil voltage of the magnetic contactor is 200 V class, and the resistance regeneration converter unit and the drive unit are 400 V class.

Note 2. The bus voltage decreases depending on the main circuit voltage and operation pattern, which may cause the forced stop deceleration to shift to the dynamic brake deceleration. When dynamic brake deceleration is not required, slow the time to turn off the magnetic contactor.

Note 3. When the voltage between L11 and L21 drops due to an instantaneous power failure and others, the magnetic contactor is turned off.

4. MR-CR_ RESISTANCE REGENERATION CONVERTER UNIT

When the resistance regeneration converter unit receives a start command from the drive unit, CNP1-2 and L21 are shorted, and the control circuit power is supplied to the magnetic contactor. When the control circuit power is supplied, the magnetic contactor is turned on, and the main circuit power is supplied to the resistance regeneration converter unit.

In the following cases, CNP1-2 and L21 in the resistance regeneration converter unit are opened, and the main circuit power supply is automatically shut off.

- 1) An alarm occurred in the resistance regeneration converter unit.
 - 2) An alarm occurred in the drive unit.
 - 3) The forced stop (EM1) of the resistance regeneration converter unit was disabled.
 - 4) [AL. 95 STO warning] occurred in the drive unit.
- (b) When magnetic contactor drive output is disabled
The main circuit power supply is not automatically shut off even when an alarm occurs in the resistance regeneration converter unit or the drive unit. Therefore, configure an external circuit to shut off the main circuit power supply when detecting an alarm.

4. MR-CR_ RESISTANCE REGENERATION CONVERTER UNIT

(2) Wiring diagram

(a) When magnetic contactor drive output is enabled (factory setting)

POINT
● The resistance regeneration converter unit controls the magnetic contactor.
● Connect the resistance regeneration converter unit and the drive unit with MR-J3CDL05M protection coordination cable.
● Always turn on or off the control circuit power supplies of the resistance regeneration converter unit and the drive unit simultaneously.

1) 200 V class

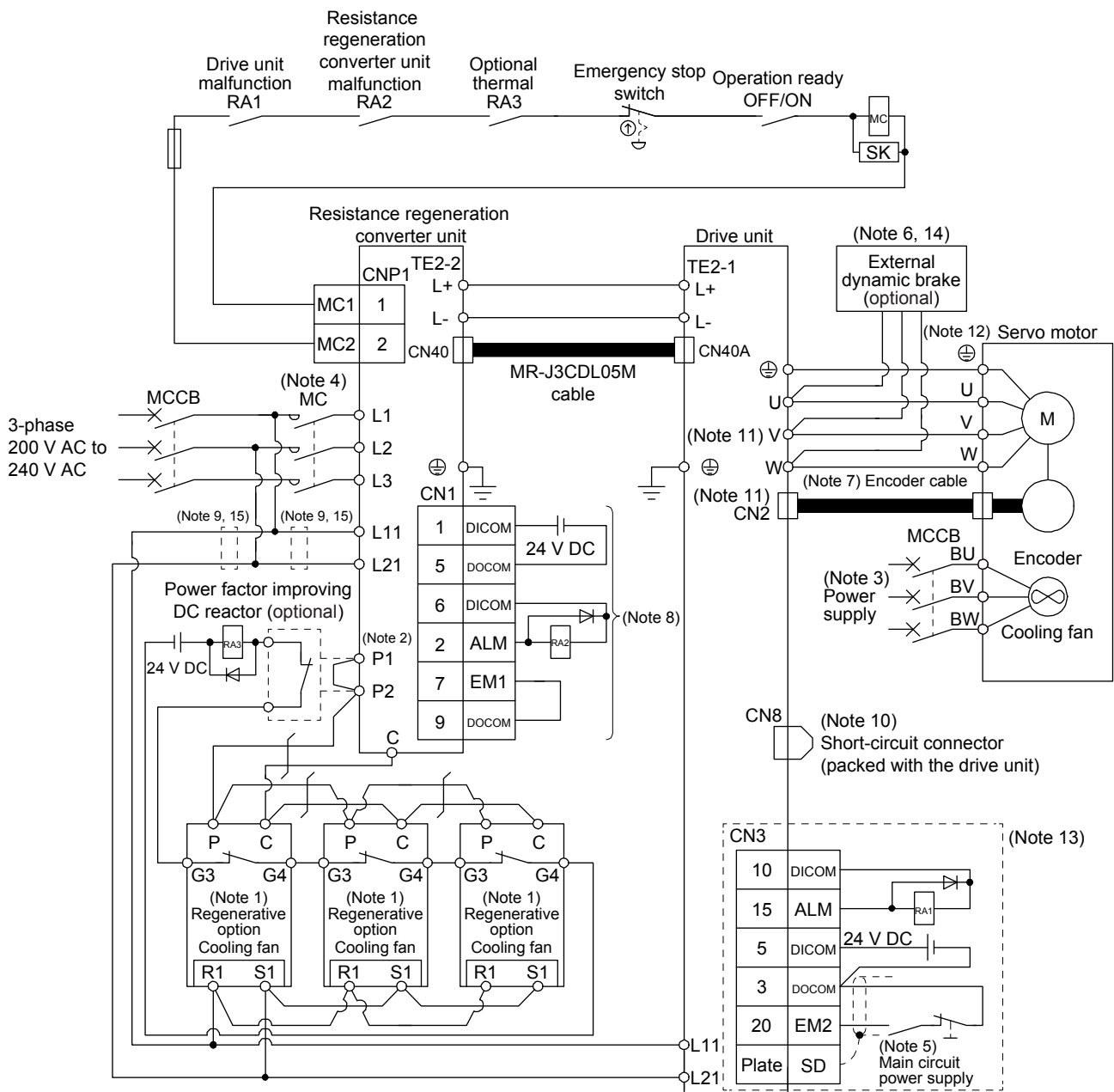

4. MR-CR_ RESISTANCE REGENERATION CONVERTER UNIT

- Note
1. This is for MR-RB137. For the MR-RB137, three units are used as one set (permissible regenerative power: 3900 W).
 2. P1 and P2 are connected by default. When using the power factor improving DC reactor, connect P1 and P2 after removing the short bar across them. Refer to section 8.6 for details.
 3. For specifications of the cooling fan power supply, refer to "Servo Motor Instruction Manual (Vol. 3)".
 4. Use a magnetic contactor with an operation delay time (interval between current being applied to the coil until closure of contacts) of 80 ms or less. The bus voltage decreases depending on the main circuit voltage and operation pattern, which may cause the forced stop deceleration to shift to the dynamic brake deceleration. When dynamic brake deceleration is not required, slow the time to turn off the magnetic contactor.
 5. To prevent an unexpected restart of the drive unit, configure a circuit to turn off EM2 in the drive unit when the main circuit power is turned off.
 6. Use an external dynamic brake for the drive unit. Failure to do so will cause an accident because the servo motor does not stop immediately but coasts at an alarm occurrence for which the servo motor does not decelerate to stop. Ensure the safety in the entire equipment. For alarms for which the servo motor does not decelerate to stop, refer to chapter 6. For wiring of the external dynamic brake, refer to section 8.3.
 7. For the encoder cable, use of the option cable is recommended. For selecting cables, refer to "Servo Motor Instruction Manual (Vol. 3)".
 8. This diagram shows sink I/O interface. For source I/O interface, refer to section 4.3.6 (2).
 9. Install an overcurrent protection device (molded-case circuit breaker or fuse) to protect the branch circuit. (Refer to section 8.5.)
 10. When not using the STO function, attach the short-circuit connector supplied with the drive unit.
 11. Do not connect a servo motor of the wrong axis to U, V, W, or CN2 of the drive unit. Otherwise, a malfunction may occur.
 12. For connecting servo motor power wires, refer to "Servo Motor Instruction Manual (Vol. 3)".
 13. The wiring is for MR-J4-DU_B_(-RJ). The connections to the interfaces of MR-J4-DU_(-RJ) are the same as in the case of MR-J4_(-RJ). Refer to each servo amplifier instruction manual.
 14. The external dynamic brake cannot be used for compliance with SEMI-F47 standard. Do not assign DB. Failure to do so will cause the drive unit to become servo-off when an instantaneous power failure occurs.
 15. The control circuit power supply (L11/L21) can be connected by passing wiring. Refer to section 6.8 for the wire size and the selection of the overcurrent protection device.

4. MR-CR_ RESISTANCE REGENERATION CONVERTER UNIT

2) 400 V class

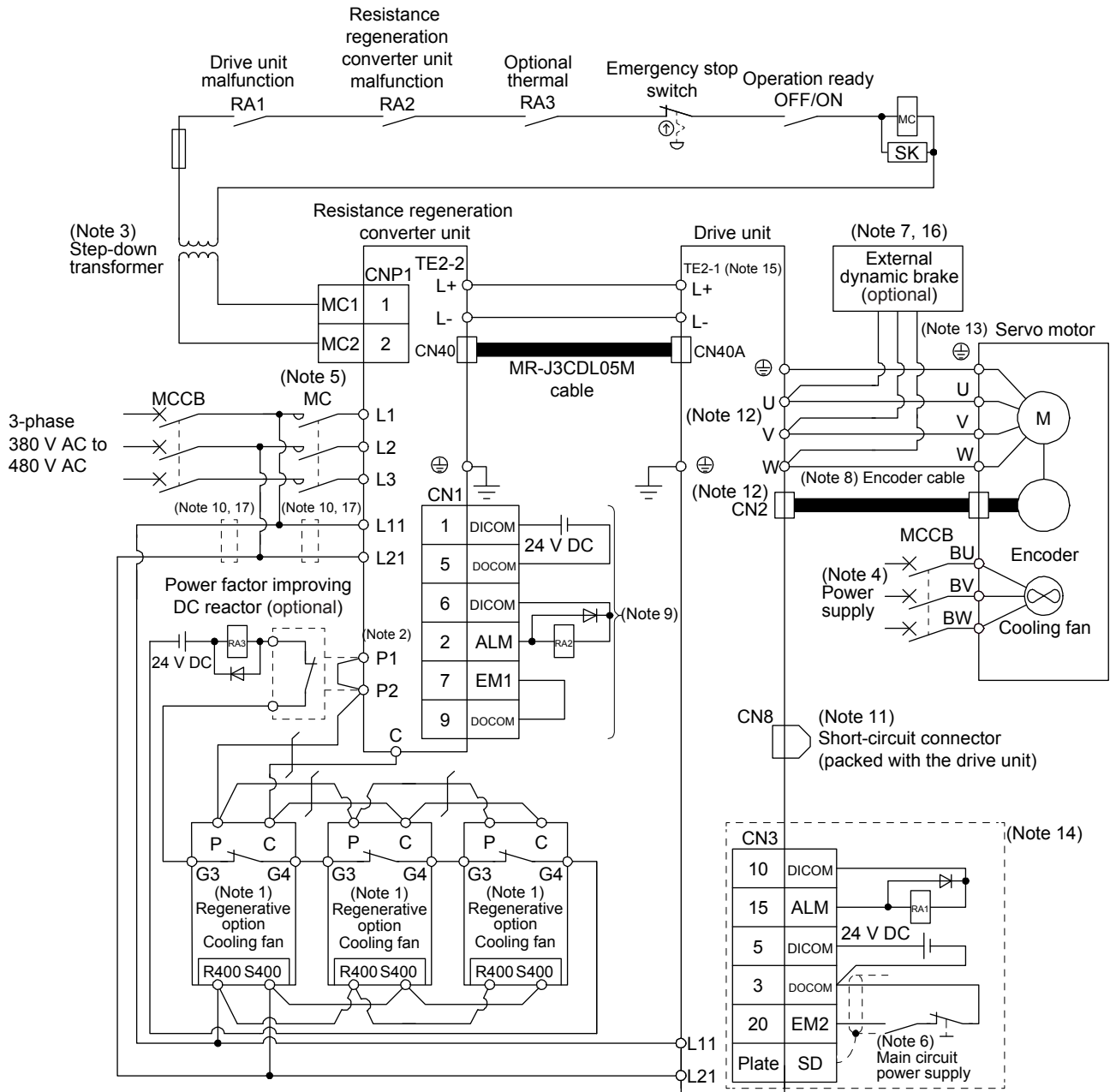

4. MR-CR_ RESISTANCE REGENERATION CONVERTER UNIT

- Note
1. This is for MR-RB13V-4. For the MR-RB13V-4, three units are used as one set (permissible regenerative power: 3900 W).
 2. P1 and P2 are connected by default. When using the power factor improving DC reactor, connect P1 and P2 after removing the short bar across them. Refer to section 8.6 for details.
 3. A step-down transformer is required when the coil voltage of the magnetic contactor is 200 V class.
 4. For specifications of the cooling fan power supply, refer to "Servo Motor Instruction Manual (Vol. 3)".
 5. Use a magnetic contactor with an operation delay time (interval between current being applied to the coil until closure of contacts) of 80 ms or less. The bus voltage decreases depending on the main circuit voltage and operation pattern, which may cause the forced stop deceleration to shift to the dynamic brake deceleration. When dynamic brake deceleration is not required, slow the time to turn off the magnetic contactor.
 6. To prevent an unexpected restart of the drive unit, configure a circuit to turn off EM2 in the drive unit when the main circuit power is turned off.
 7. Use an external dynamic brake for the drive unit. Failure to do so will cause an accident because the servo motor does not stop immediately but coasts at an alarm occurrence for which the servo motor does not decelerate to stop. Ensure the safety in the entire equipment. For alarms for which the servo motor does not decelerate to stop, refer to chapter 6. For wiring of the external dynamic brake, refer to section 8.3.
 8. For the encoder cable, use of the option cable is recommended. For selecting cables, refer to "Servo Motor Instruction Manual (Vol. 3)".
 9. This diagram shows sink I/O interface. For source I/O interface, refer to section 4.3.6 (2).
 10. Install an overcurrent protection device (molded-case circuit breaker or fuse) to protect the branch circuit. (Refer to section 8.5.)
 11. When not using the STO function, attach the short-circuit connector supplied with the drive unit.
 12. Do not connect the servo motor of a wrong axis to U, V, W, or CN2 of the drive unit. Otherwise, a malfunction may occur.
 13. For connecting servo motor power wires, refer to "Servo Motor Instruction Manual (Vol. 3)".
 14. The wiring is for MR-J4-DU_B_(-RJ). The connections to the interfaces of MR-J4-DU_(-RJ) are the same as in the case of MR-J4_(-RJ). Refer to each servo amplifier instruction manual.
 15. For the MR-J4-DU30K_4(-RJ) and MR-J4-DU37K_4(-RJ), the terminal block is TE2.
 16. The external dynamic brake cannot be used for compliance with SEMI-F47 standard. Do not assign DB. Failure to do so will cause the drive unit to become servo-off when an instantaneous power failure occurs.
 17. The control circuit power supply (L11/L21) can be connected by passing wiring. Refer to section 6.8 for the wire size and the selection of the overcurrent protection device.

4. MR-CR_ RESISTANCE REGENERATION CONVERTER UNIT

(b) When magnetic contactor drive output is disabled

POINT
<ul style="list-style-type: none"> ● Connect the resistance regeneration converter unit and the drive unit with MR-J3CDL05M protection coordination cable. ● Always turn on or off the control circuit power supplies of the resistance regeneration converter unit and the drive unit simultaneously.

1) 200 V class

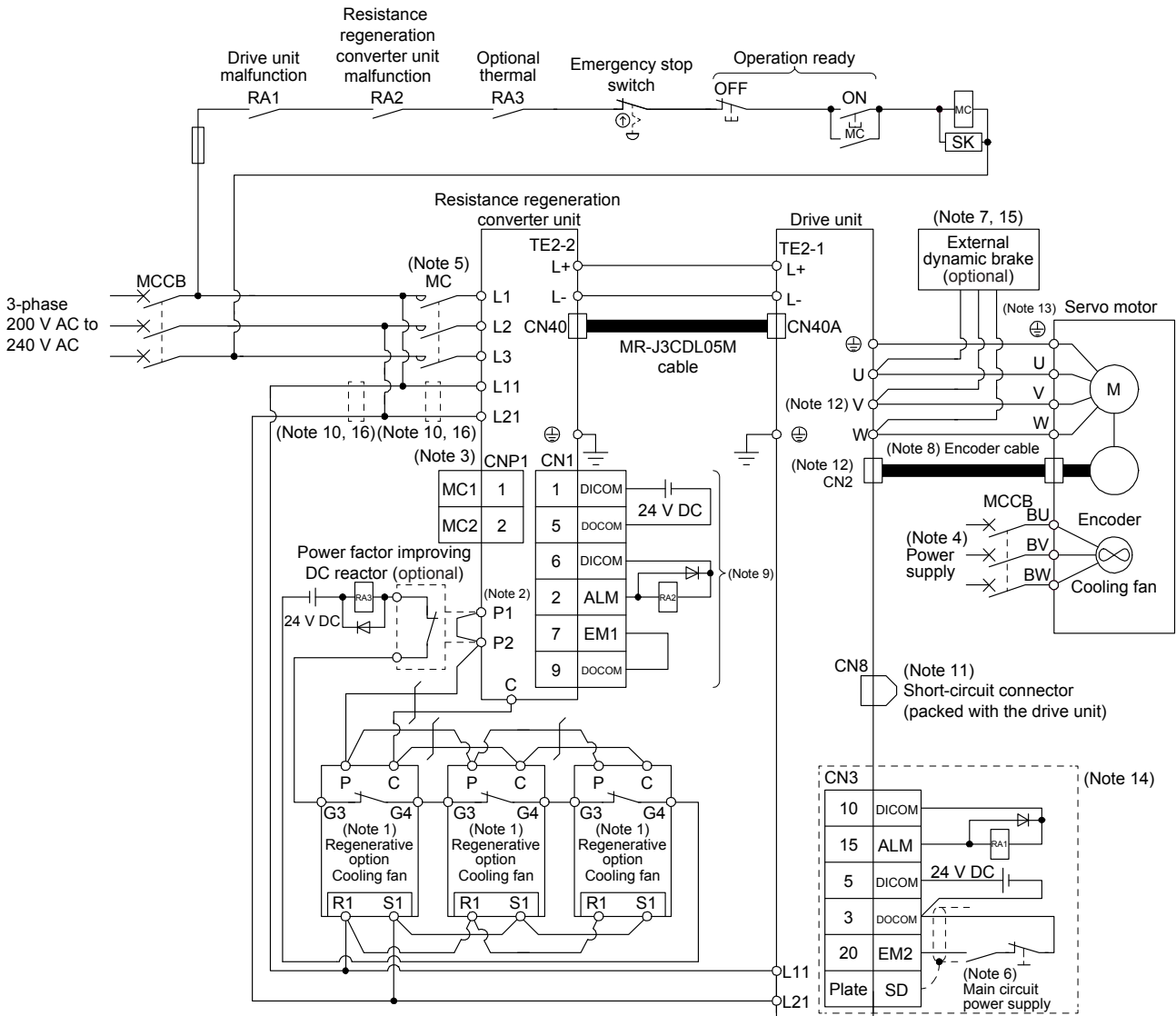

4. MR-CR_ RESISTANCE REGENERATION CONVERTER UNIT

- Note
1. This is for MR-RB137. For the MR-RB137, three units are used as one set (permissible regenerative power: 3900 W).
 2. P1 and P2 are connected by default. When using the power factor improving DC reactor, connect P1 and P2 after removing the short bar across them. Refer to section 8.6 for details.
 3. Always connect the magnetic contactor wiring connector to CNP1 of the resistance regeneration converter unit. If the connector is not connected, an electric shock may occur.
 4. For specifications of the cooling fan power supply, refer to "Servo Motor Instruction Manual (Vol. 3)".
 5. Use a magnetic contactor with an operation delay time (interval between current being applied to the coil until closure of contacts) of 80 ms or less. The bus voltage decreases depending on the main circuit voltage and operation pattern, which may cause the forced stop deceleration to shift to the dynamic brake deceleration. When dynamic brake deceleration is not required, slow the time to turn off the magnetic contactor.
 6. To prevent an unexpected restart of the drive unit, configure a circuit to turn off EM2 in the drive unit when the main circuit power is turned off.
 7. Use an external dynamic brake for the drive unit. Failure to do so will cause an accident because the servo motor does not stop immediately but coasts at an alarm occurrence for which the servo motor does not decelerate to stop. Ensure the safety in the entire equipment. For alarms for which the servo motor does not decelerate to stop, refer to chapter 6. For wiring of the external dynamic brake, refer to section 8.3.
 8. For the encoder cable, use of the option cable is recommended. For selecting cables, refer to "Servo Motor Instruction Manual (Vol. 3)".
 9. This diagram shows sink I/O interface. For source I/O interface, refer to section 4.3.6 (2).
 10. Install an overcurrent protection device (molded-case circuit breaker or fuse) to protect the branch circuit. (Refer to section 8.5.)
 11. When not using the STO function, attach the short-circuit connector supplied with the drive unit.
 12. Do not connect the servo motor of a wrong axis to U, V, W, or CN2 of the drive unit. Otherwise, a malfunction may occur.
 13. For connecting servo motor power wires, refer to "Servo Motor Instruction Manual (Vol. 3)".
 14. The wiring is for MR-J4-DU_B_(-RJ). The connections to the interfaces of MR-J4-DU_(-RJ) are the same as in the case of MR-J4_(-RJ). Refer to each servo amplifier instruction manual.
 15. The external dynamic brake cannot be used for compliance with SEMI-F47 standard. Do not assign DB. Failure to do so will cause the drive unit to become servo-off when an instantaneous power failure occurs.
 16. The control circuit power supply (L11/L21) can be connected by passing wiring. Refer to section 6.8 for the wire size and the selection of the overcurrent protection device.

4. MR-CR_ RESISTANCE REGENERATION CONVERTER UNIT

2) 400 V class

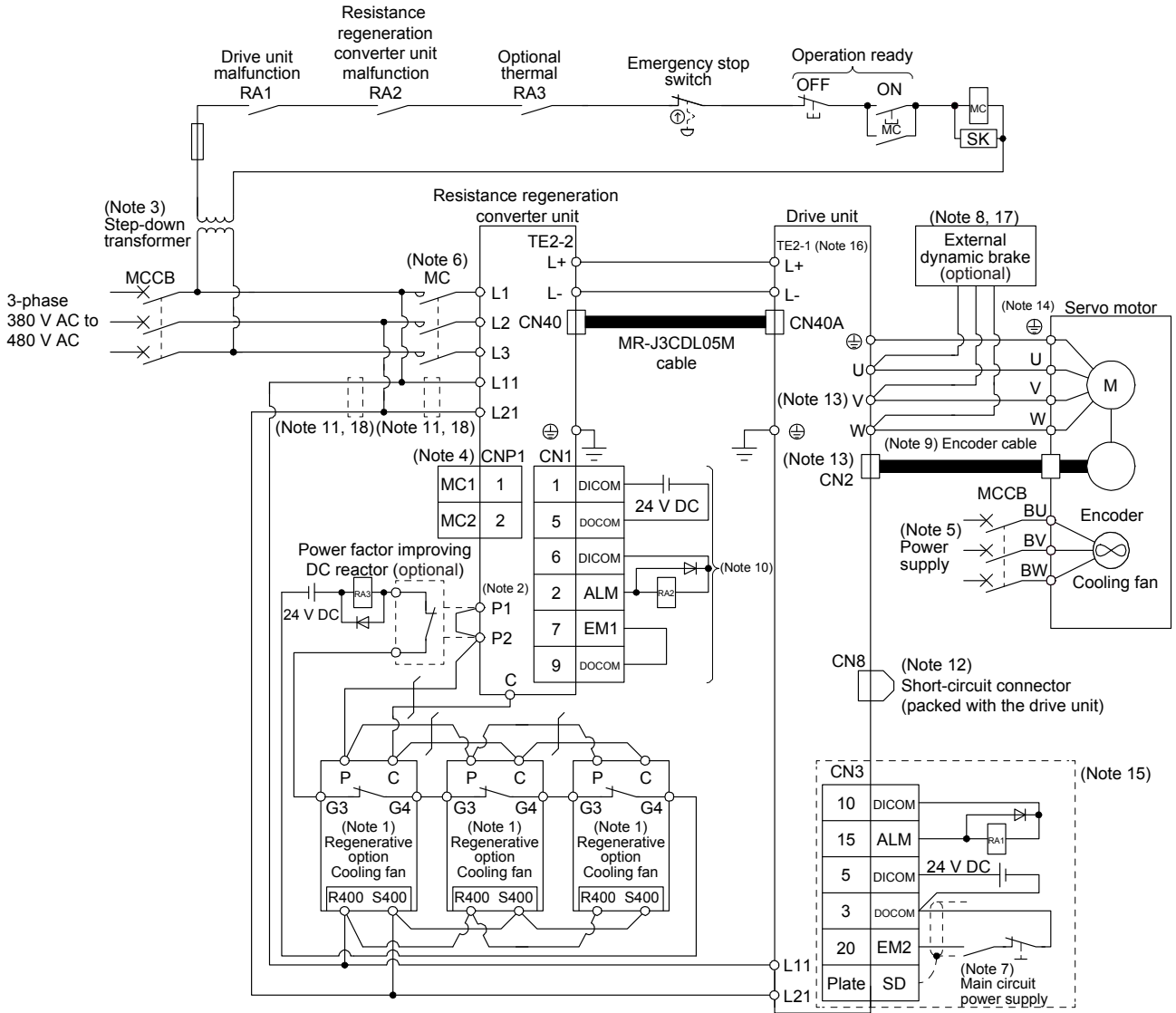

4. MR-CR_ RESISTANCE REGENERATION CONVERTER UNIT

- Note
1. This is for MR-RB13V-4. For the MR-RB13V-4, three units are used as one set (permissible regenerative power: 3900 W).
 2. P1 and P2 are connected by default. When using the power factor improving DC reactor, connect P1 and P2 after removing the short bar across them. Refer to section 8.6 for details.
 3. A step-down transformer is required when the coil voltage of the magnetic contactor is 200 V class.
 4. Always connect the magnetic contactor wiring connector to CNP1 of the resistance regeneration converter unit. If the connector is not connected, an electric shock may occur.
 5. For specifications of the cooling fan power supply, refer to "Servo Motor Instruction Manual (Vol. 3)".
 6. Use a magnetic contactor with an operation delay time (interval between current being applied to the coil until closure of contacts) of 80 ms or less. The bus voltage decreases depending on the main circuit voltage and operation pattern, which may cause the forced stop deceleration to shift to the dynamic brake deceleration. When dynamic brake deceleration is not required, slow the time to turn off the magnetic contactor.
 7. To prevent an unexpected restart of the drive unit, configure a circuit to turn off EM2 in the drive unit when the main circuit power is turned off.
 8. Use an external dynamic brake for the drive unit. Failure to do so will cause an accident because the servo motor does not stop immediately but coasts at an alarm occurrence for which the servo motor does not decelerate to stop. Ensure the safety in the entire equipment. For alarms for which the servo motor does not decelerate to stop, refer to chapter 6. For wiring of the external dynamic brake, refer to section 8.3.
 9. For the encoder cable, use of the option cable is recommended. For selecting cables, refer to "Servo Motor Instruction Manual (Vol. 3)".
 10. This diagram shows sink I/O interface. For source I/O interface, refer to section 4.3.6 (2).
 11. Install an overcurrent protection device (molded-case circuit breaker or fuse) to protect the branch circuit. (Refer to section 8.5.)
 12. When not using the STO function, attach the short-circuit connector supplied with the drive unit.
 13. Do not connect the servo motor of a wrong axis to U, V, W, or CN2 of the drive unit. Otherwise, a malfunction may occur.
 14. For connecting servo motor power wires, refer to "Servo Motor Instruction Manual (Vol. 3)".
 15. The wiring is for MR-J4-DU_B_(-RJ). The connections to the interfaces of MR-J4-DU_(-RJ) are the same as in the case of MR-J4_(-RJ). Refer to each servo amplifier instruction manual.
 16. For the MR-J4-DU30K_4(-RJ) and MR-J4-DU37K_4(-RJ), the terminal block is TE2.
 17. The external dynamic brake cannot be used for compliance with SEMI-F47 standard. Do not assign DB. Failure to do so will cause the drive unit to become servo-off when an instantaneous power failure occurs.
 18. The control circuit power supply (L11/L21) can be connected by passing wiring. Refer to section 6.8 for the wire size and the selection of the overcurrent protection device.

4. MR-CR_ RESISTANCE REGENERATION CONVERTER UNIT

(3) How to use the bus bars

Make sure to use the supplied bus bars and connect the L+ and L- of the drive unit to those of the resistance regeneration converter unit as shown below. Never use bus bars other than the ones supplied with the drive unit. Both the units are shown with the terminal cover open.

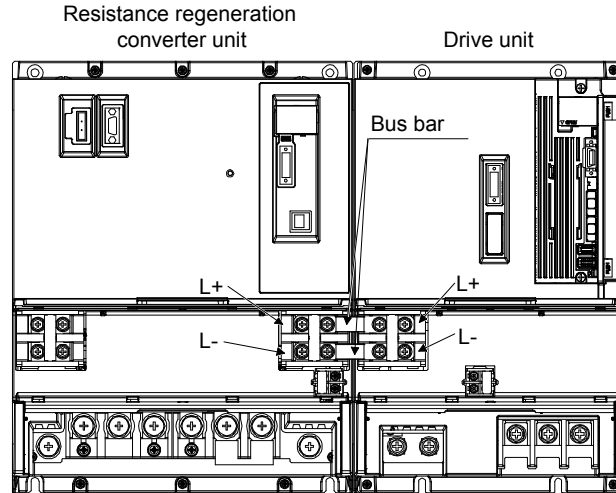

4.3.2 Explanation of power supply system

(1) Signal explanations

POINT
● For the layout of the terminal block, refer to chapter 7 DIMENSIONS.

Connection target (application)	Symbol	(Note) Terminal block	Description	
			MR-CR55K	MR-CR55K4
Main circuit power supply	L1/L2/L3	TE1-1	Supply 3-phase 200 V AC to 240 V AC, 50 Hz/60 Hz power to L1, L2, and L3.	Supply 3-phase 380 V AC to 480 V AC, 50 Hz/60 Hz power to L1, L2, and L3.
Control circuit power supply	L11/L21	TE3	Supply 1-phase 200 V AC to 240 V AC, 50 Hz/60 Hz power to L11 and L21.	Supply 1-phase 380 V AC to 480 V AC, 50 Hz/60 Hz power to L11 and L21.
Power factor improving DC reactor	P1/P2	TE1-2	When using the power factor improving DC reactor, connect P1 and P2 after removing the short bar across them.	
Regenerative option	P2/C	TE1-2	Connect the regenerative option between P2 and C.	
Brake unit	L+/L-	TE2-1	When using a brake unit, connect it to this terminal. Do not connect anything other than the brake unit.	
Drive unit	L+/L-	TE2-2	Connect the L+ and L- of the drive unit to this terminal. Use the bus bars supplied with the drive unit to connect.	
Protective earth (PE)	⊕	PE	Connect the protective earth (PE) of the cabinet to this terminal.	

Note. The permissible tension applied to any of the terminal blocks TE1-1, TE1-2, TE2-1, TE2-2 is 350 N.

4. MR-CR_ RESISTANCE REGENERATION CONVERTER UNIT

(2) Power-on sequence

(a) MR-J4-DU_B_(-RJ)

1) Power-on procedure

- a) Always use a magnetic contactor for the main circuit power supply wiring (L1/L2/L3) as shown in above section 4.3.1 (2). Configure an external sequence to switch off the magnetic contactor as soon as an alarm occurs.
- b) Turn on the control circuit power supplies (L11/L21) of the resistance regeneration converter unit and drive unit simultaneously with the main circuit power supply or before turning on the main circuit power supply. If the main circuit power supply is not on, the display shows the corresponding warning. However, by switching on the main circuit power supply, the warning disappears and the drive unit will operate properly.

2) Timing chart

- a) When magnetic contactor drive output is enabled and the status remains at ready-on
The main circuit power is not shut off with servo-off.

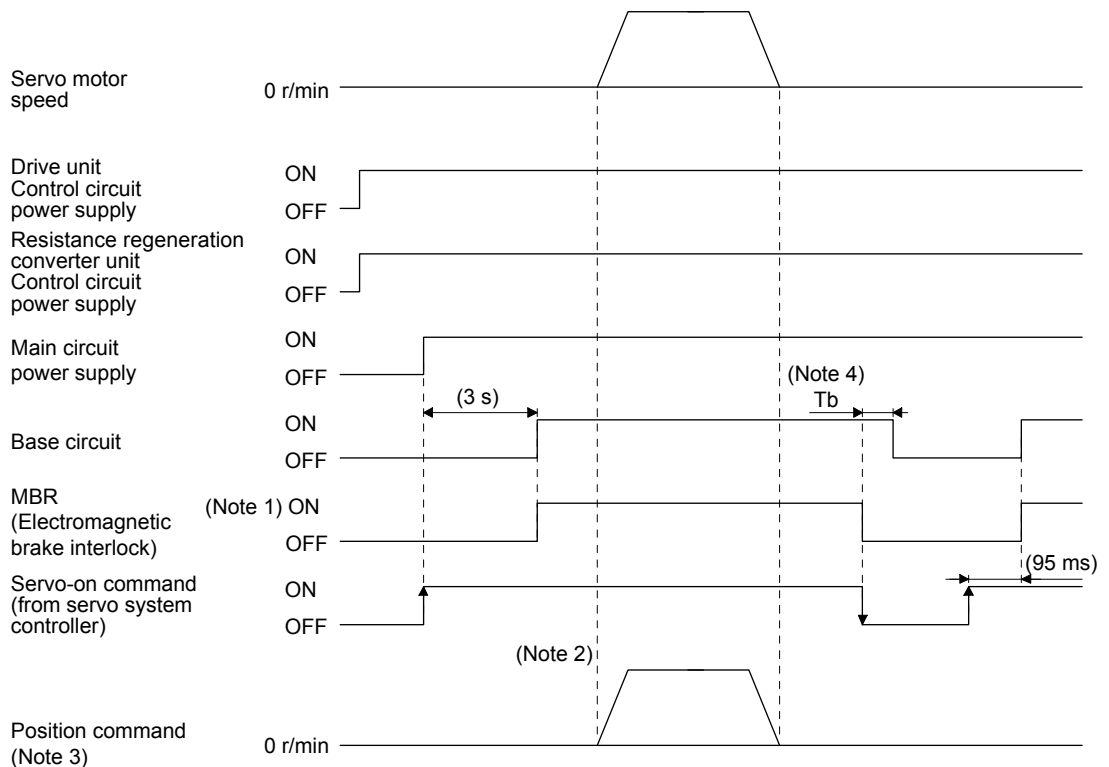

- Note 1. When setting up an electromagnetic brake at customer's side, make up a sequence which will operate the electromagnetic brake as follow using MBR.
- ON: Electromagnetic brake is not activated.
 - OFF: Electromagnetic brake is activated.
2. Give a position command after the external electromagnetic brake is released.
 3. This is in position control mode.
 4. In [Pr. PC02 Electromagnetic brake sequence output], set a delay time (T_b) from MBR off to base circuit shut-off at a servo-off.

4. MR-CR_ RESISTANCE REGENERATION CONVERTER UNIT

- b) When magnetic contactor drive output is enabled and the status returns to ready-off
 The magnetic contactor of the resistance regeneration converter unit is turned off with ready-off, and the main circuit power supply is shut off.

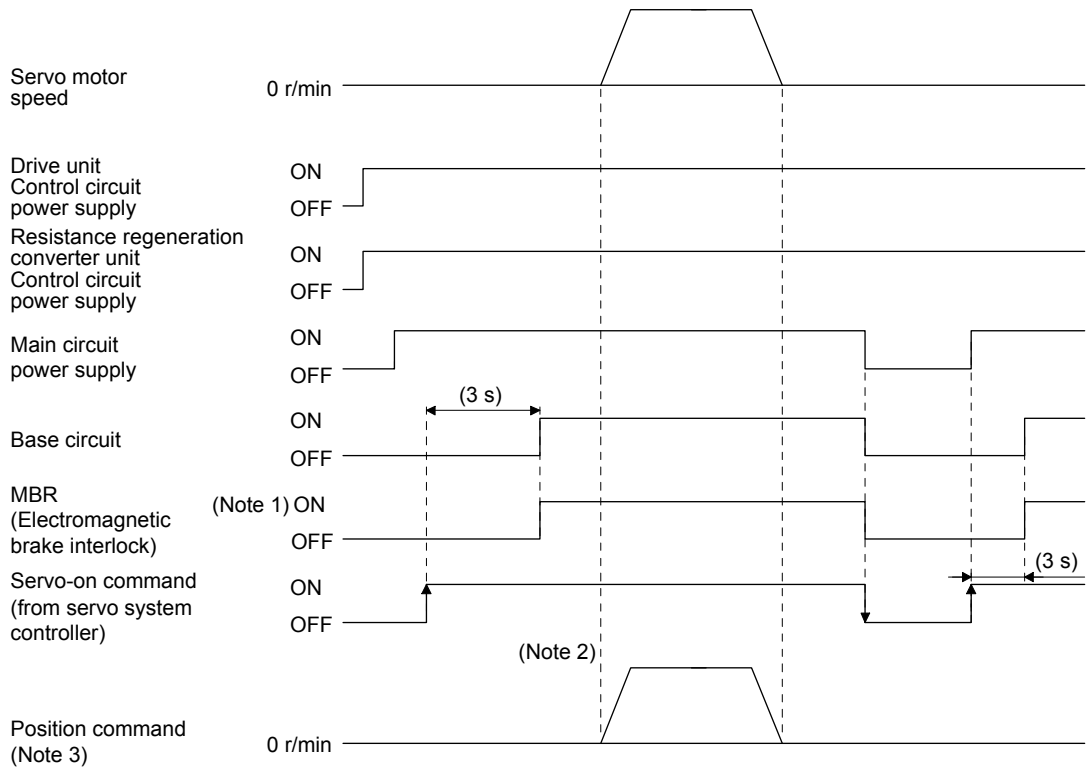

Note 1. When setting up an electromagnetic brake at customer's side, make up a sequence which will operate the electromagnetic brake as follow using MBR.

ON: Electromagnetic brake is not activated.

OFF: Electromagnetic brake is activated.

2. Give a position command after the external electromagnetic brake is released.

3. This is in position control mode.

4. MR-CR_ RESISTANCE REGENERATION CONVERTER UNIT

c) When magnetic contactor drive output is disabled

When an alarm occurs, turn off the magnetic contactor using the external sequence, and shut off the main circuit power supply.

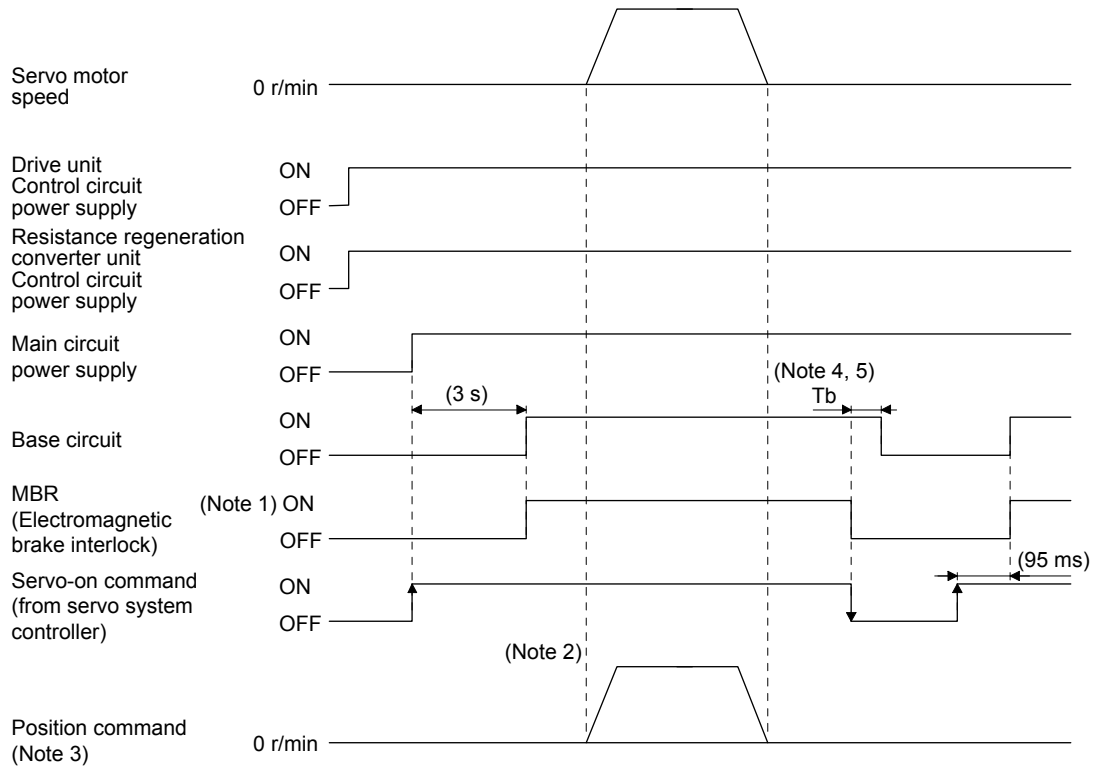

- Note 1. When setting up an electromagnetic brake at customer's side, make up a sequence which will operate the electromagnetic brake as follow using MBR.
 ON: Electromagnetic brake is not activated.
 OFF: Electromagnetic brake is activated.
2. Give a position command after the external electromagnetic brake is released.
 3. This is in position control mode.
 4. In [Pr. PC02 Electromagnetic brake sequence output], set a delay time (T_b) from MBR off to base circuit shut-off at a servo-off.
 5. The base circuit remains ready-on status at servo-off. When the status is ready-off, the base circuit and the servo-on command turn off at the same time. ($T_b = 0$)

4. MR-CR_ RESISTANCE REGENERATION CONVERTER UNIT

(b) MR-J4-DU_A_(-RJ)

1) Power-on procedure

a) Always use a magnetic contactor for the main circuit power supply wiring (L1/L2/L3) as shown in above section 4.3.1 (2). Configure an external sequence to switch off the magnetic contactor as soon as an alarm occurs.

b) When enabling magnetic contactor drive output, turn on the control circuit power supplies (L11/L21) of the resistance regeneration converter unit and the drive unit simultaneously. The main circuit power supply is automatically turned on after the resistance regeneration converter unit and drive unit are started.

When using an external sequence to control the magnetic contactor, turn on the control circuit power supplies (L11/ L21) of the resistance regeneration converter unit and drive unit simultaneously with the main circuit power supply or before turning on the main circuit power supply. If the main circuit power supply is not on, the display shows the corresponding warning. However, by switching on the main circuit power supply, the warning disappears and the drive unit will operate properly.

2) Timing chart

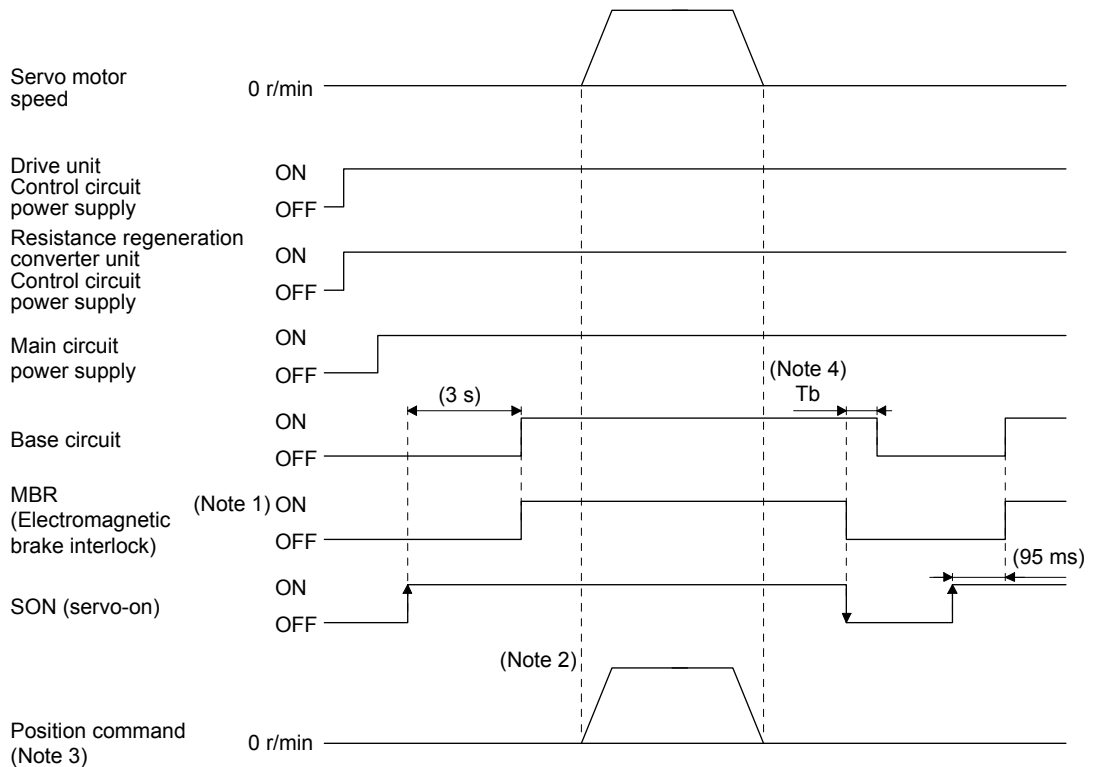

- Note 1. When setting up an electromagnetic brake at customer's side, make up a sequence which will operate the electromagnetic brake as follow using MBR.
 ON: Electromagnetic brake is not activated.
 OFF: Electromagnetic brake is activated.
- Note 2. Give a position command after the external electromagnetic brake is released.
- Note 3. This is in position control mode.
- Note 4. In [Pr. PC16 Electromagnetic brake sequence output], set a delay time (T_b) from MBR off to base circuit shut-off at a servo-off.

4. MR-CR_ RESISTANCE REGENERATION CONVERTER UNIT

4.3.3 Connectors and pin assignment

POINT

● The pin assignment of the connectors is as viewed from the cable connector wiring section.

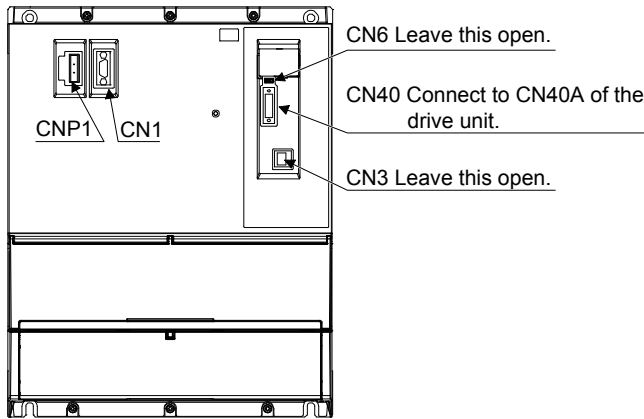

CN1 (Digital I/O connector)
 Model: 17JE-23090-02(D8A)K11-CG (D-sub 9 pin or equivalent)
 (DDK)

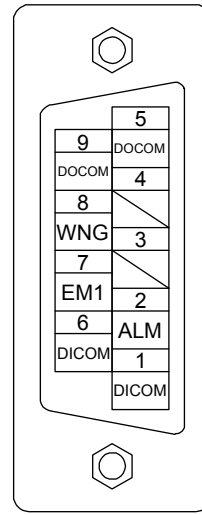

CNP1 (Magnetic contactor wiring connector)
 Model: GFKC 2,5/2-STF-7,62
 (Phoenix Contact)

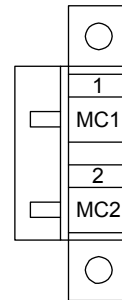

4. MR-CR_ RESISTANCE REGENERATION CONVERTER UNIT

4.3.4 Signal (device) explanations

The following table lists the resistance regeneration converter unit signals (devices).

For the I/O interfaces (symbols in I/O division column in the table), refer to section 4.3.6 (1).

Signal (device)	Symbol	Connector pin No.	Function and application	I/O division
Digital I/F power supply input	DICOM	CN1-1 CN1-6	Input 24 V DC (24 V DC \pm 10% 150 mA) for I/O interface. The power supply capacity changes depending on the number of I/O interface points to be used. For sink interface, connect + of 24 V DC external power supply. For source interface, connect - of 24 V DC external power supply.	
Forced stop	EM1	CN1-7	When MR-CR55K is used with MR-J4-DU_(-RJ), EM1 is not used. Connect between EM1 and Docom externally. Turn EM1 off to bring the resistance regeneration converter unit to a forced stop state. In this state, the magnetic connector is turned off, [AL. E9 Main circuit off warning] occurs in the drive unit, and the servo-on turns off. When the resistance regeneration converter unit is in the forced stop state, turning EM1 on resets the state.	DI
Malfunction	ALM	CN1-2	ALM turns off when power is switched off or the protective circuit is activated. When no alarm occurs, ALM turns on 1.5 s after power-on.	DO
Warning	WNG	CN1-8	When warning has occurred, WNG turns on.	DO
Digital I/F common	DOCOM	CN1-5 CN1-9	Common terminal for the ALM and WNG output signals of the resistance regeneration converter unit. This is separated from LG. Pins are connected internally. For sink interface, connect - of 24 V DC external power supply. For source interface, connect + of 24 V DC external power supply.	
Magnetic contactor drive output	MC1	CNP1-1	Connect it to the coil of the magnetic contactor. Always supplies the control circuit power since it is conducted with L11 in the resistance regeneration converter unit. <div style="border: 1px solid black; padding: 5px; display: inline-block;">  WARNING <ul style="list-style-type: none"> ● Always connect the magnetic contactor wiring connector to CNP1 of the resistance regeneration converter unit. Disconnected state may cause an electric shock. </div>	
	MC2	CNP1-2	Connect it to the coil of the magnetic contactor. When the resistance regeneration converter unit receives a start command from the drive unit, CNP1-2 and L21 are shorted, and the control circuit power is supplied to the magnetic contactor. Set "___0" in [Pr. PA02] when controlling the magnetic contactor without magnetic contactor control connector (CNP1). (Refer to section 4.3.1 (1).)	

4. MR-CR_ RESISTANCE REGENERATION CONVERTER UNIT

4.3.5 Alarm occurrence timing chart



- When an alarm has occurred, remove its cause, make sure that the operation signal is not begin inputted, ensure safety, and reset the alarm before restarting operation.
- As soon as an alarm occurs, make the Servo-off status and interrupt the main circuit power.

(1) MR-J4-DU_B_(-RJ)

(a) When magnetic contactor drive output is enabled

1) Resistance regeneration converter unit

When an alarm occurs in the resistance regeneration converter unit, the magnetic contactor is turned off and the main circuit magnetic contactor is shut off. The drive unit in operation stops. To deactivate the alarm, cycle the control circuit power or request the operation from the driver unit.

However, the alarm cannot be deactivated unless its cause is removed.

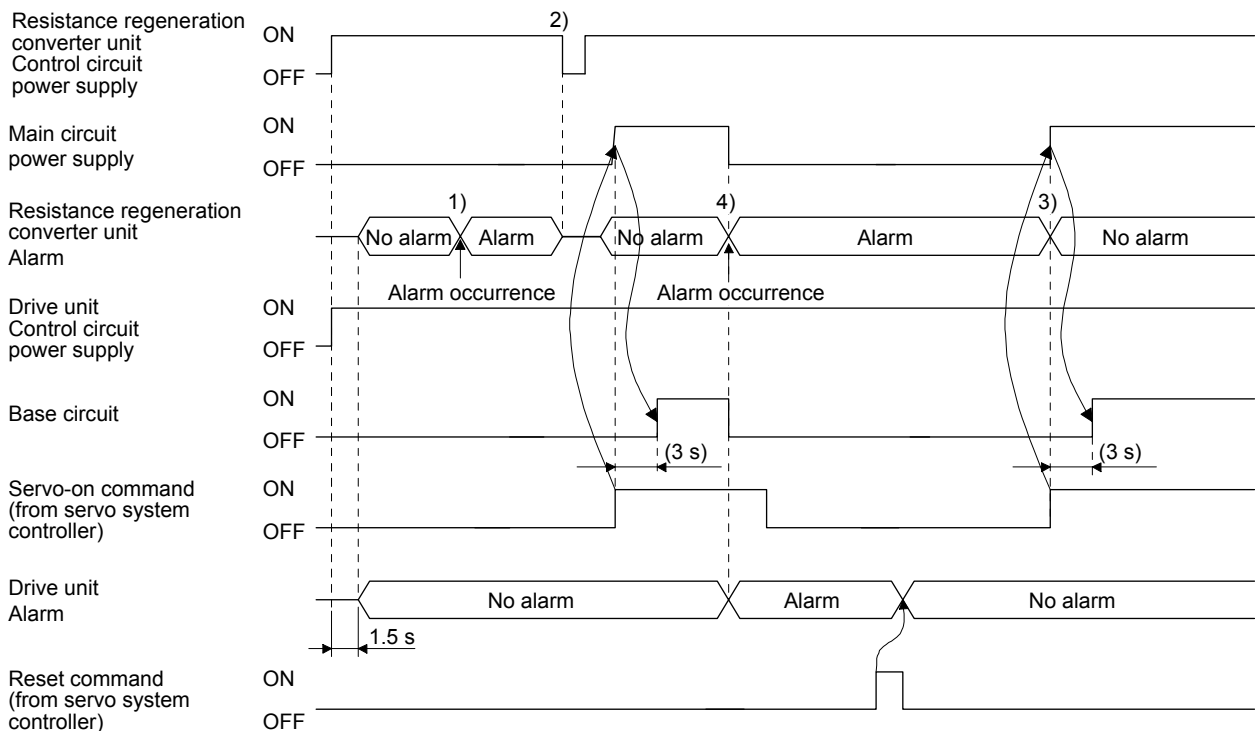

1) in figure When the drive unit is at servo-off, even if an alarm occurs in the resistance regeneration converter unit, the drive unit does not detect the alarm.

2) and 3) in figure To deactivate the alarm of the resistance regeneration converter unit, cycle the power of the resistance regeneration converter unit (2)), or turn on the servo-on command (3)). Refer to section 6.1 for the alarms that can be reset with the servo-on command on.

4) in figure If an alarm occurs in the resistance regeneration converter unit when the drive unit is at servo-on, the alarm also occurs in the drive unit and the drive unit becomes servo-off.

4. MR-CR_ RESISTANCE REGENERATION CONVERTER UNIT

2) Drive unit

When an alarm occurs on the drive unit, the base circuit is shut off and the servo motor coasts.

When an external dynamic brake is used, the external dynamic brake is activated to stop the servo motor. To deactivate the alarm, cycle the control circuit power, or give the error reset or CPU reset command from the servo system controller. However, the alarm cannot be deactivated unless its cause is removed.

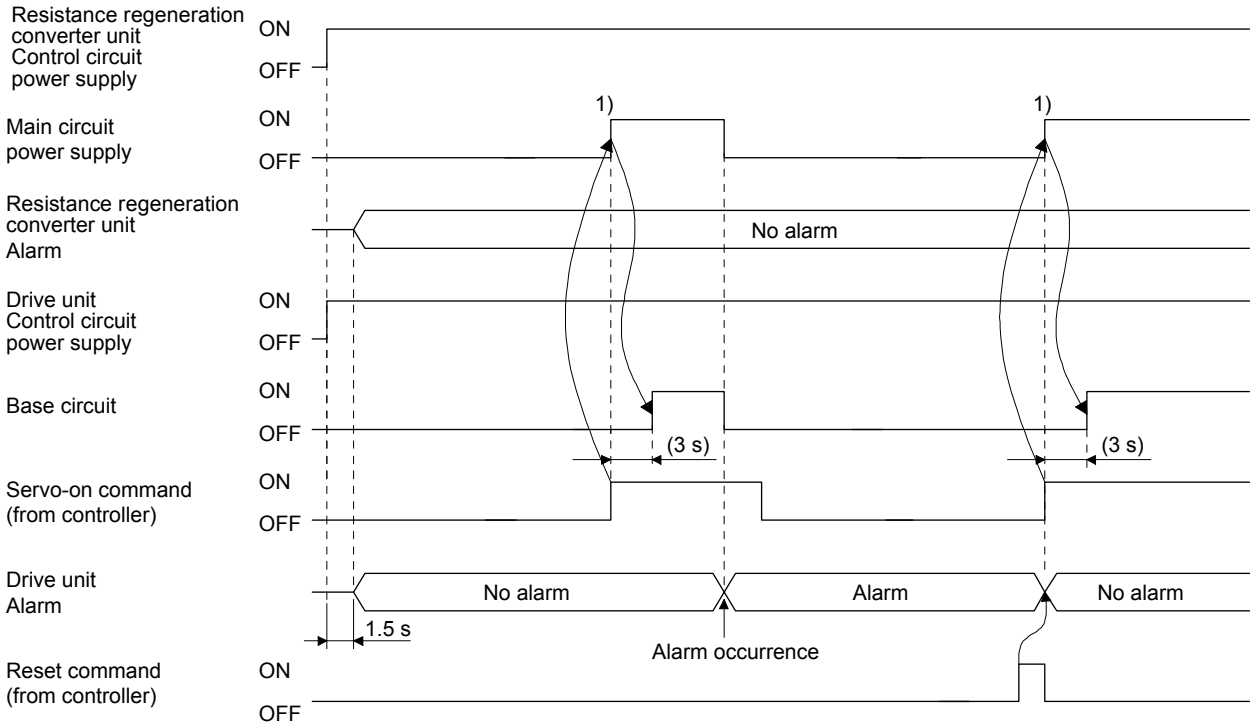

1) in figure

After the start-up of the drive unit is completed, the main circuit power is supplied while the drive unit and the resistance regeneration converter unit have no alarm.

4. MR-CR_ RESISTANCE REGENERATION CONVERTER UNIT

(b) When magnetic contactor drive output is disabled

1) Resistance regeneration converter unit

When an alarm occurs in the resistance regeneration converter unit, the resistance regeneration converter unit turns into servo-off, but the main circuit power supply is not shut off. Therefore, shut off the main circuit power supply using the external sequence. Cancel the alarm in the resistance regeneration converter unit. If an alarm also occurs in the drive unit, cancel the alarm in the drive unit as well. Then, turn on the error reset command from the servo system controller to resume the operation.

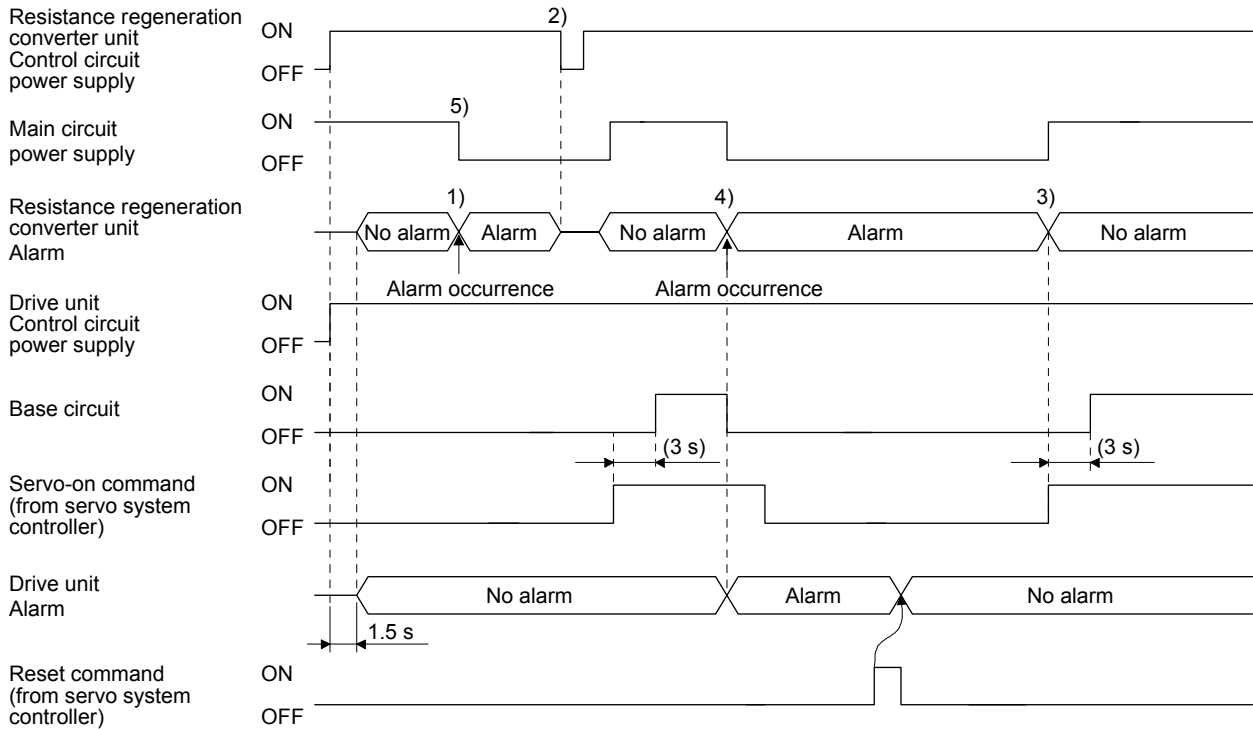

- 1) in figure When the drive unit is at servo-off, even if an alarm occurs in the resistance regeneration converter unit, the drive unit does not detect the alarm.
- 2) and 3) in figure To deactivate the alarm of the resistance regeneration converter unit, cycle the power of the resistance regeneration converter unit (2)), or turn on the servo-on command (3)). Refer to section 6.1 for the alarms that can be reset with the servo-on command on.
- 4) in figure If an alarm occurs in the resistance regeneration converter unit when the drive unit is at servo-on, the alarm also occurs in the drive unit and the drive unit becomes servo-off.
- 5) in figure Shut off the main circuit power supply using the external sequence as soon as an alarm occurs.

4. MR-CR_ RESISTANCE REGENERATION CONVERTER UNIT

2) Drive unit

When an alarm occurs in the drive unit, the drive unit turns into the servo-off, but the main circuit power supply is not shut off. Therefore, shut off the main circuit power supply using the external sequence. After cancelling the alarm in the drive unit, turn on the error reset command from the servo system controller to resume the operation.

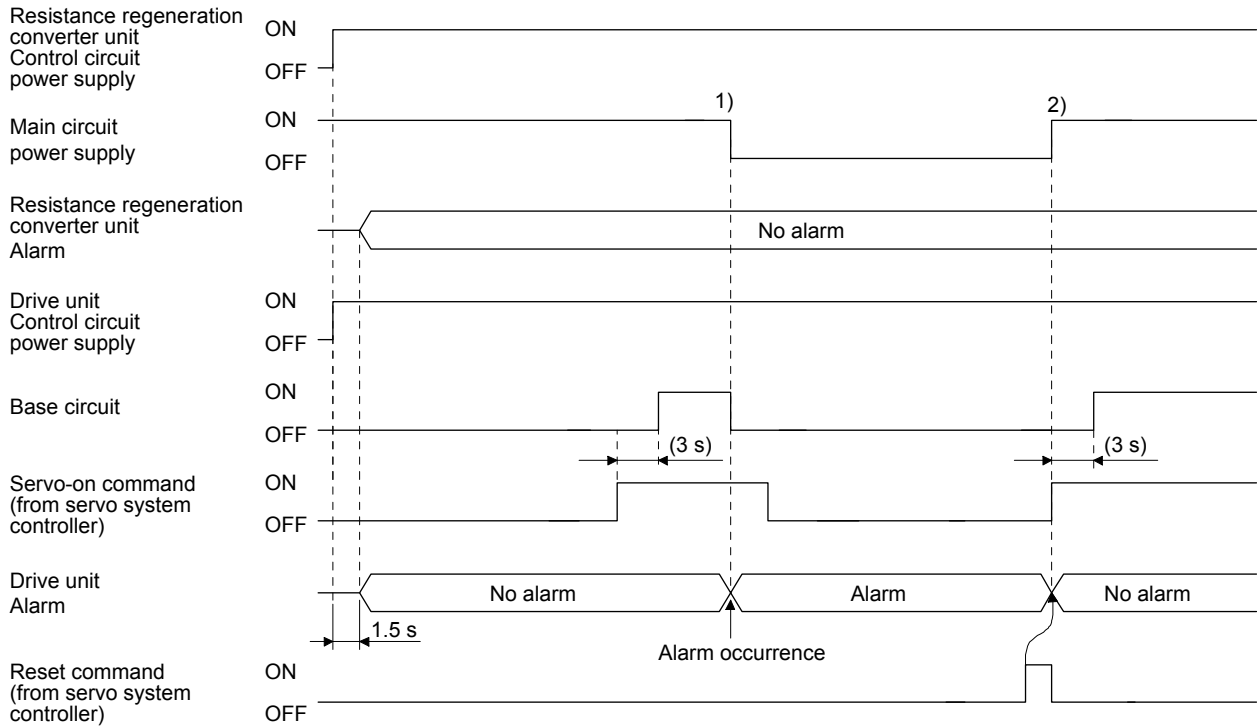

1) in figure When an alarm occurs in the drive unit, shut off the main circuit power supply using the external sequence.

2) in figure Turn on the main circuit power supply while an alarm in the drive unit is cancelled.

4. MR-CR_ RESISTANCE REGENERATION CONVERTER UNIT

(2) MR-J4-DU_A_(-RJ)

(a) When magnetic contactor drive output is enabled

1) Resistance regeneration converter unit

When an alarm occurs in the resistance regeneration converter unit, the magnetic contactor is turned off and the main circuit magnetic contactor is shut off. The drive unit in operation stops. To deactivate the alarm, cycle the control circuit power. However, the alarm cannot be deactivated unless its cause is removed.

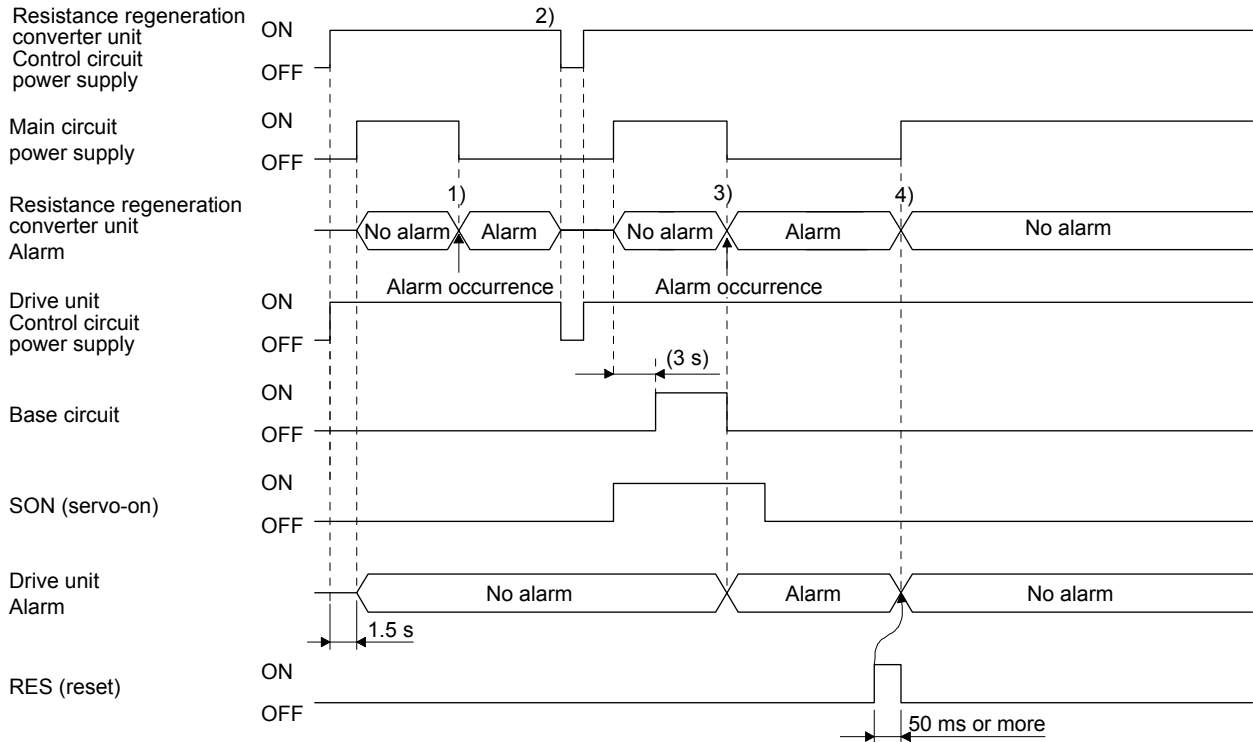

- 1) in figure When the drive unit is at servo-off, even if an alarm occurs in the resistance regeneration converter unit, the drive unit does not detect the alarm.
- 2) in figure To deactivate the alarm of the resistance regeneration converter unit, cycle the power of the resistance regeneration converter unit.
- 3) in figure If an alarm occurs in the resistance regeneration converter unit when the drive unit is at servo-on, the alarm also occurs in the drive unit and the drive unit becomes servo-off.
- 4) in figure When alarms occur in both the resistance regeneration converter unit and the drive unit, cancelling the alarm in the drive unit will also cancel the alarm in the resistance regeneration converter unit.

4. MR-CR_ RESISTANCE REGENERATION CONVERTER UNIT

2) Drive unit

When an alarm occurs in the drive unit, the base circuit is shut off and the servo motor coasts.

When an external dynamic brake (option) is used, the external dynamic brake is activated to stop the servo motor. To deactivate an alarm, cycle the control circuit power, click "SET" in the current alarm window, or cycle the RES (Reset). However, the alarm cannot be deactivated unless its cause is removed.

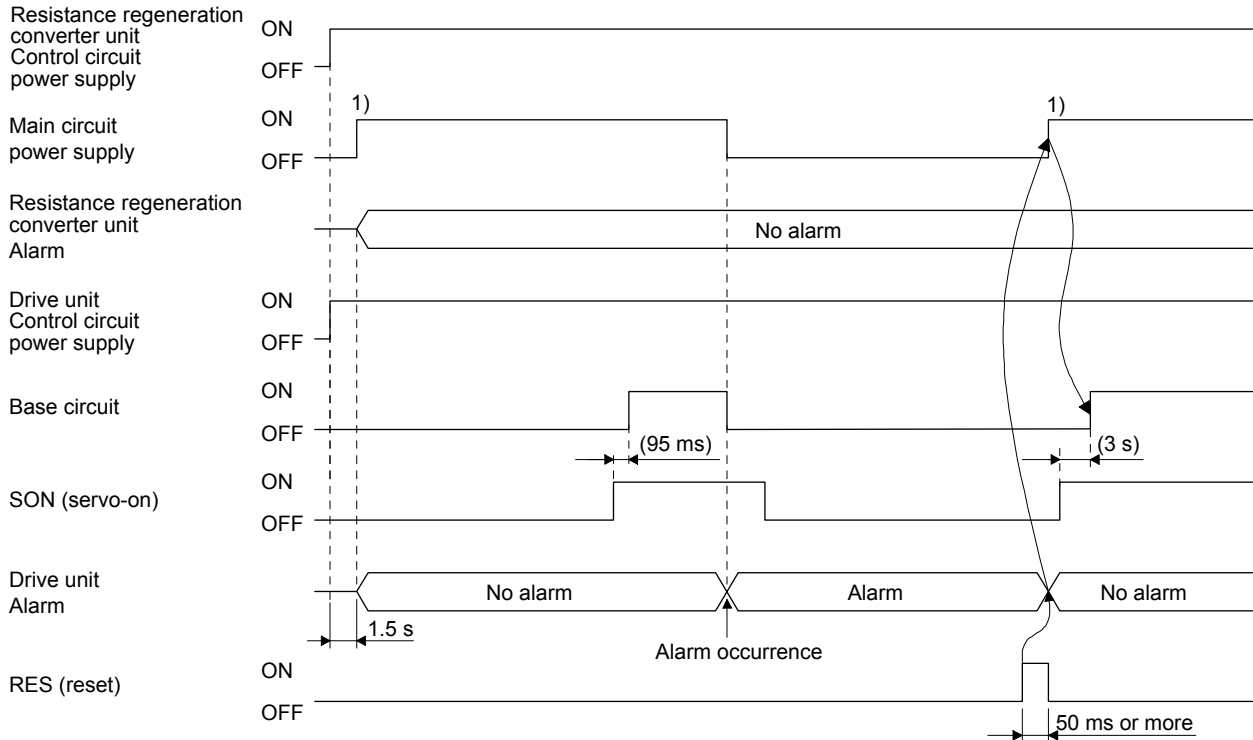

1) in figure

After the start-up of the drive unit is completed, the main circuit power is supplied while the drive unit and the resistance regeneration converter unit have no alarm.

4. MR-CR_ RESISTANCE REGENERATION CONVERTER UNIT

(b) When magnetic contactor drive output is disabled

1) Resistance regeneration converter unit

When an alarm occurs in the resistance regeneration converter unit, the resistance regeneration converter unit turns into servo-off, but the main circuit power supply is not shut off. Therefore, shut off the main circuit power supply using the external sequence. Cancel the alarm in the resistance regeneration converter unit. If an alarm also occurs in the drive unit, cancel the alarm in the drive unit as well. Then, turn on the RES (Reset) to resume the operation.

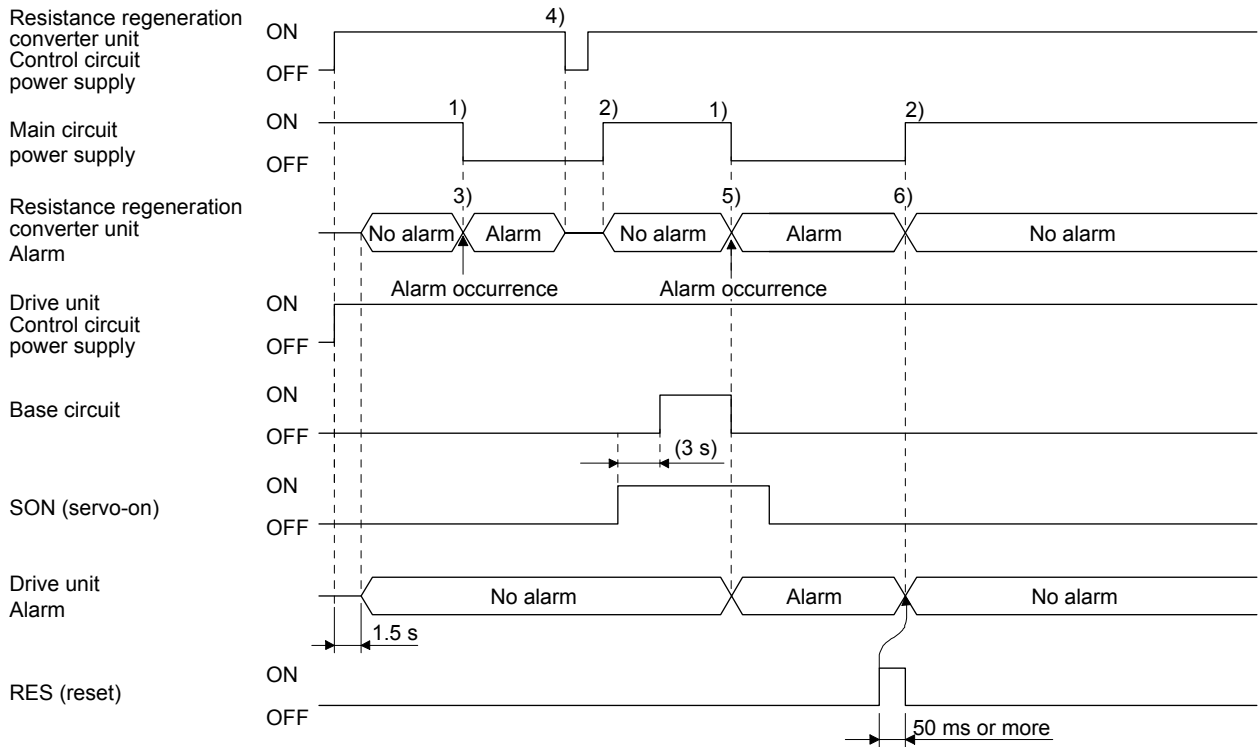

- 1) in figure When an alarm occurs in the resistance regeneration converter unit, shut off the main circuit power supply using the external sequence.
- 2) in figure Turn on the main circuit power supply while an alarm in the drive unit is cancelled.
- 3) in figure When the drive unit is at servo-off, even if an alarm occurs in the resistance regeneration converter unit, the drive unit does not detect the alarm.
- 4) in figure To deactivate the alarm of the resistance regeneration converter unit, cycle the power of the resistance regeneration converter unit.
- 5) in figure If an alarm occurs in the resistance regeneration converter unit when the drive unit is at servo-on, the alarm also occurs in the drive unit and the drive unit becomes servo-off.
- 6) in figure When alarms occur in both the resistance regeneration converter unit and the drive unit, cancelling the alarm in the drive unit will also cancel the alarm in the resistance regeneration converter unit.

4. MR-CR_ RESISTANCE REGENERATION CONVERTER UNIT

2) Drive unit

When an alarm occurs in the drive unit, the drive unit turns into the servo-off, but the main circuit power supply is not shut off. Therefore, shut off the main circuit power supply using the external sequence. After cancelling the alarm in the drive unit, turn on the RES (Reset) to resume the operation.

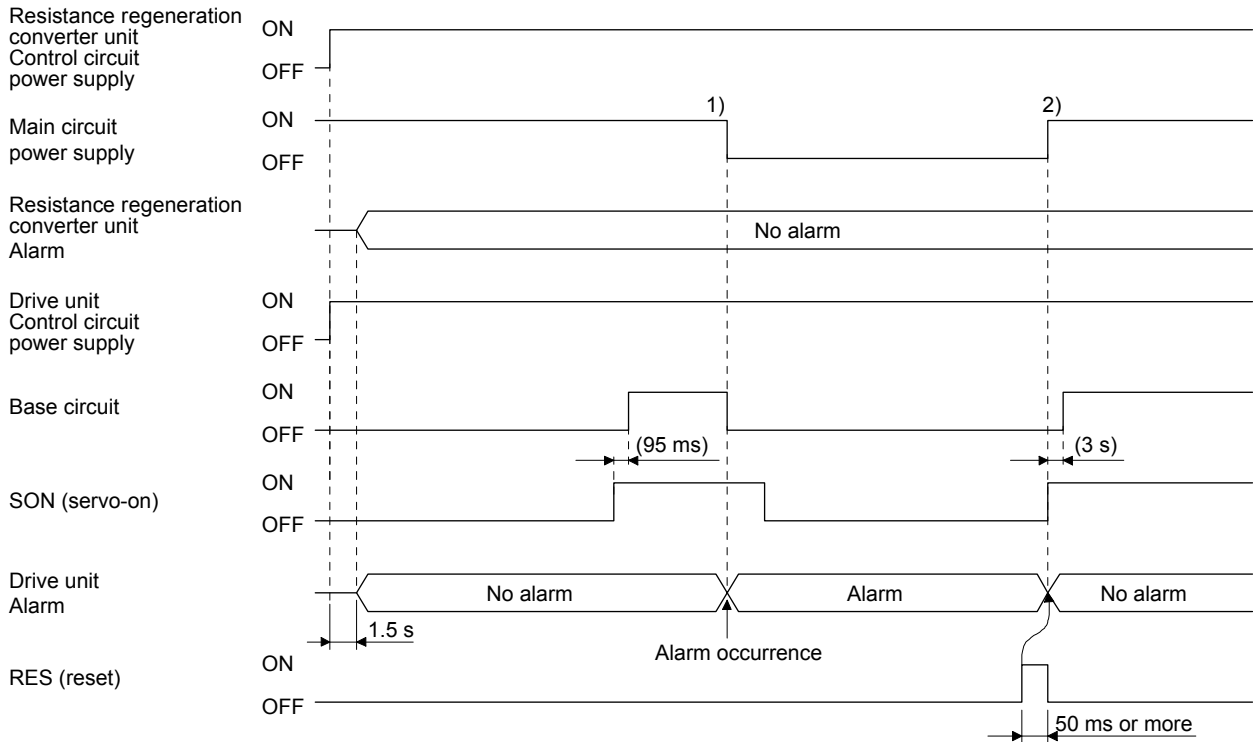

1) in figure When an alarm occurs in the drive unit, shut off the main circuit power supply using the external sequence.

2) in figure Turn on the main circuit power supply while an alarm in the drive unit is cancelled.

4. MR-CR_ RESISTANCE REGENERATION CONVERTER UNIT

4.3.6 Forced stop in the resistance regeneration converter unit

(1) MR-J4-DU_B_(-RJ)

(a) When magnetic contactor drive output is enabled

When EM1 (Forced stop) is disabled in the resistance regeneration converter unit, the magnetic contactor turns off and the main circuit power supply shuts off. The drive unit in operation stops, and [AL. E9 Main circuit off warning] appears. When EM1 is enabled in the resistance regeneration converter unit, the magnetic contactor turns on, the main circuit power is supplied, and then the drive unit automatically resumes the operation.

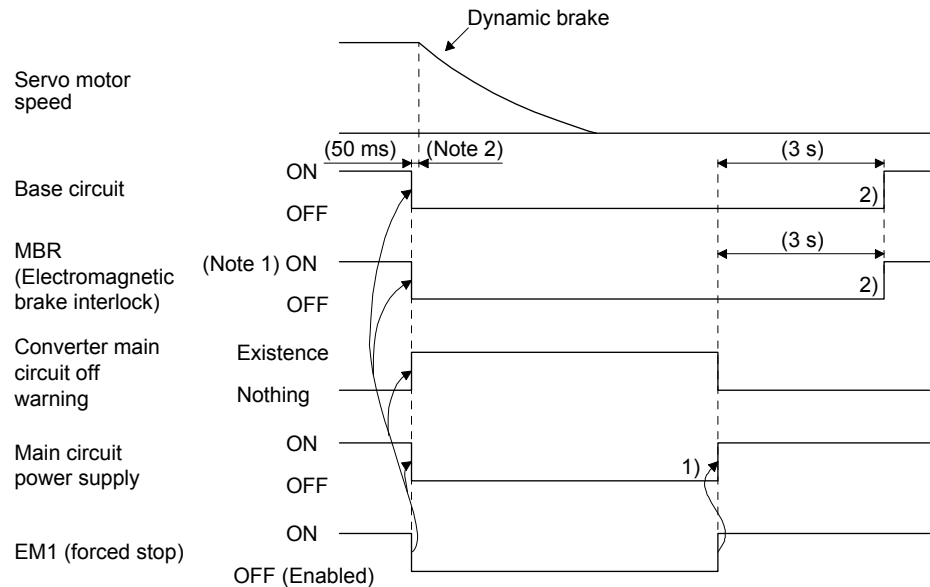

- Note 1. When setting up an electromagnetic brake at customer's side, make up a sequence which will operate the electromagnetic brake as follow using MBR.
 ON: Electromagnetic brake is not activated.
 OFF: Electromagnetic brake is activated.
- Note 2. There is delay caused by magnetic contactor built into the external dynamic brake (about 50 ms) and delay caused by the external relay.

1) in figure When EM1 is enabled in the resistance regeneration converter unit, the main circuit power is supplied.

2) in figure After the capacitor in the main circuit is fully charged, the base circuit and MBR (Electromagnetic brake interlock) turn on.

4. MR-CR_ RESISTANCE REGENERATION CONVERTER UNIT

(b) When magnetic contactor drive output is disabled

When EM1 (Forced stop) is disabled in the resistance regeneration converter unit, the base circuit of the drive unit that is in operation shuts off, and [AL. E9 Main circuit off warning] appears on the drive unit. When EM1 is enabled in the resistance regeneration converter unit, the drive unit automatically resumes the operation.

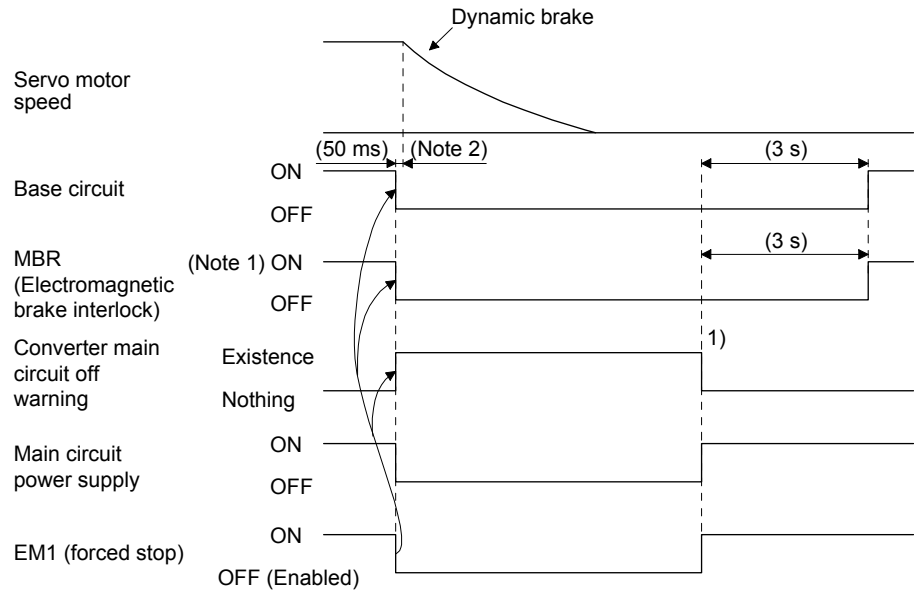

Note 1. When setting up an electromagnetic brake at customer's side, make up a sequence which will operate the electromagnetic brake as follow using MBR.

ON: Electromagnetic brake is not activated.

OFF: Electromagnetic brake is activated.

Note 2. There is delay caused by magnetic contactor built into the external dynamic brake (about 50 ms) and delay caused by the external relay.

1) in figure

When EM1 is enabled, the converter main circuit off warning is released.

4. MR-CR_ RESISTANCE REGENERATION CONVERTER UNIT

(2) MR-J4-DU_A_(-RJ)

(a) When magnetic contactor drive output is enabled

When EM1 (Forced stop) is disabled in the resistance regeneration converter unit, the magnetic contactor turns off and the main circuit power supply shuts off. The drive unit in operation stops, and [AL. E9 Main circuit off warning] appears. When EM1 is enabled in the resistance regeneration converter unit, the magnetic contactor turns on, the main circuit power is supplied, and then the drive unit automatically resumes the operation.

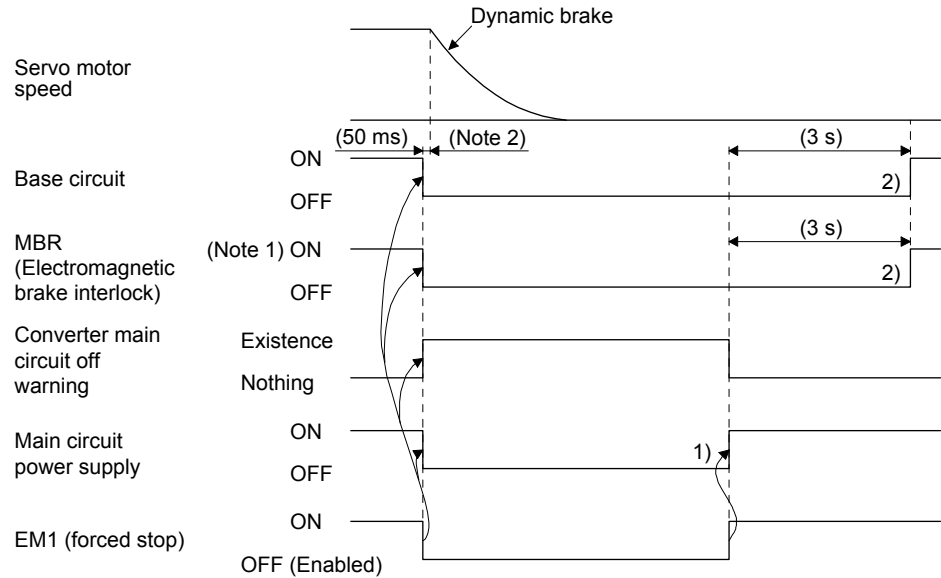

Note 1. When setting up an electromagnetic brake at customer's side, make up a sequence which will operate the electromagnetic brake as follow using MBR.

ON: Electromagnetic brake is not activated.

OFF: Electromagnetic brake is activated.

Note 2. There is delay caused by magnetic contactor built into the external dynamic brake (about 50 ms) and delay caused by the external relay.

1) in figure When EM1 is enabled in the resistance regeneration converter unit, the main circuit power is supplied.

2) in figure After the capacitor in the main circuit is fully charged, the base circuit and MBR (Electromagnetic brake interlock) turn on.

4. MR-CR_ RESISTANCE REGENERATION CONVERTER UNIT

(b) When magnetic contactor drive output is disabled

When EM1 (Forced stop) is disabled in the resistance regeneration converter unit, the base circuit of the drive unit that is in operation shuts off, and [AL. E9 Main circuit off warning] appears on the drive unit. When EM1 is enabled in the resistance regeneration converter unit, the drive unit automatically resumes the operation.

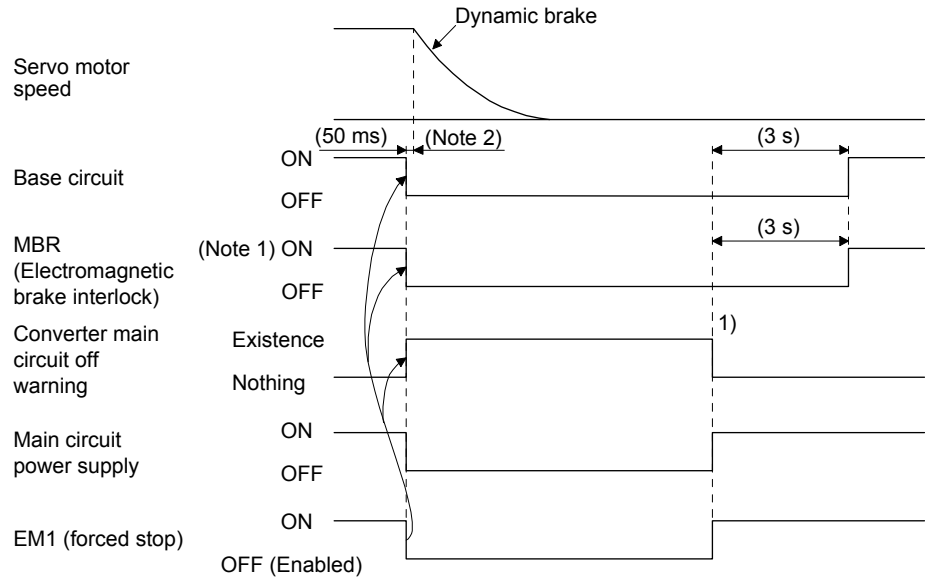

- Note 1. When setting up an electromagnetic brake at customer's side, make up a sequence which will operate the electromagnetic brake as follow using MBR.
 ON: Electromagnetic brake is not activated.
 OFF: Electromagnetic brake is activated.
- Note 2. There is delay caused by magnetic contactor built into the external dynamic brake (about 50 ms) and delay caused by the external relay.

1) in figure

When EM1 is enabled, the converter main circuit off warning is released.

4. MR-CR_ RESISTANCE REGENERATION CONVERTER UNIT

4.3.7 Interfaces

(1) Detailed explanation of interfaces

This section provides the details of the I/O signal interfaces (refer to the I/O division in the table) given in section 4.3.4. Refer to this section and make connections to the external device.

(a) Digital input interface DI

This is an input circuit in which the cathode of the photocoupler is the input terminal. Transmit signals from sink (open-collector) type transistor output, relay switch, etc. The following shows a connection diagram for sink input. Refer to (2) in this section for source input.

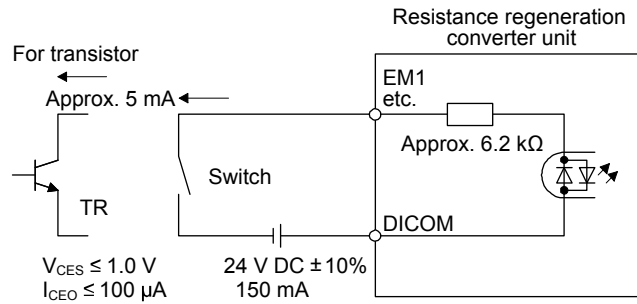

(b) Digital output interface DO

This is a circuit in which the collector of the output transistor is the output terminal. When the output transistor is turned on, the current will flow to the collector terminal.

A lamp, relay, or photocoupler can be driven. Install a diode (D) for an inductive load, or install an inrush current suppressing resistor (R) for a lamp load.

(Rated current: 40 mA or less, maximum current: 50 mA or less, inrush current: 100 mA or less)

A maximum of 2.6 V voltage drop occurs in the resistance regeneration converter unit.

The following shows a connection diagram for sink output. Refer to (2) in this section for source output.

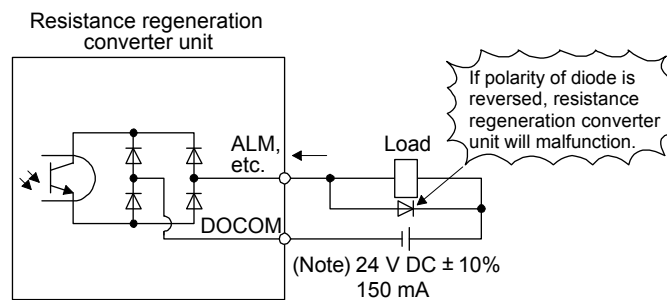

Note. If the voltage drop (maximum of 2.6 V) interferes with the relay operation, apply high voltage (maximum of 26.4 V) from external source.

4. MR-CR_ RESISTANCE REGENERATION CONVERTER UNIT

(2) Source I/O interfaces

In this resistance regeneration converter unit, source type I/O interfaces can be used.

(a) Digital input interface DI

This is an input circuit in which the anode of the photocoupler is the input terminal. Transmit signals from source (open-collector) type transistor output, relay switch, etc.

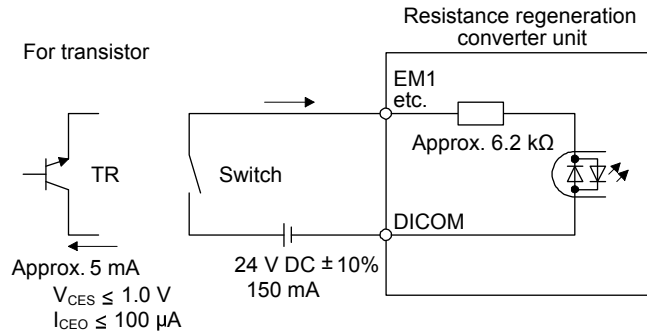

(b) Digital output interface DO

This is a circuit in which the emitter of the output transistor is the output terminal. When the output transistor is turned on, the current will flow from the output terminal to a load.

A maximum of 2.6 V voltage drop occurs in the resistance regeneration converter unit.

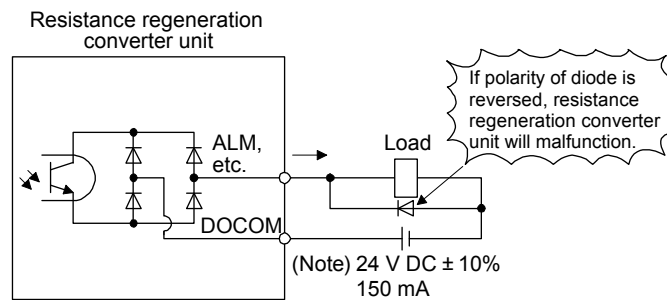

Note. If the voltage drop (maximum of 2.6 V) interferes with the relay operation, apply high voltage (maximum of 26.4 V) from external source.

4. MR-CR_ RESISTANCE REGENERATION CONVERTER UNIT

4.3.8 Grounding

WARNING

- Ground the resistance regeneration converter unit, the drive unit and the servo motor securely.
- To prevent an electric shock, always connect the protective earth (PE) terminal (marked ⊕) of the resistance regeneration converter unit and drive unit to the protective earth (PE) of the cabinet.

The drive unit switches the power transistor on-off to supply power to the servo motor. Depending on the wiring and ground cable routing, the drive unit may be affected by the switching noise (due to di/dt and dv/dt) of the transistor. To prevent such a fault, refer to the following diagram and always ground. To conform to "EMC Directive, refer to the EMC Installation Guidelines".

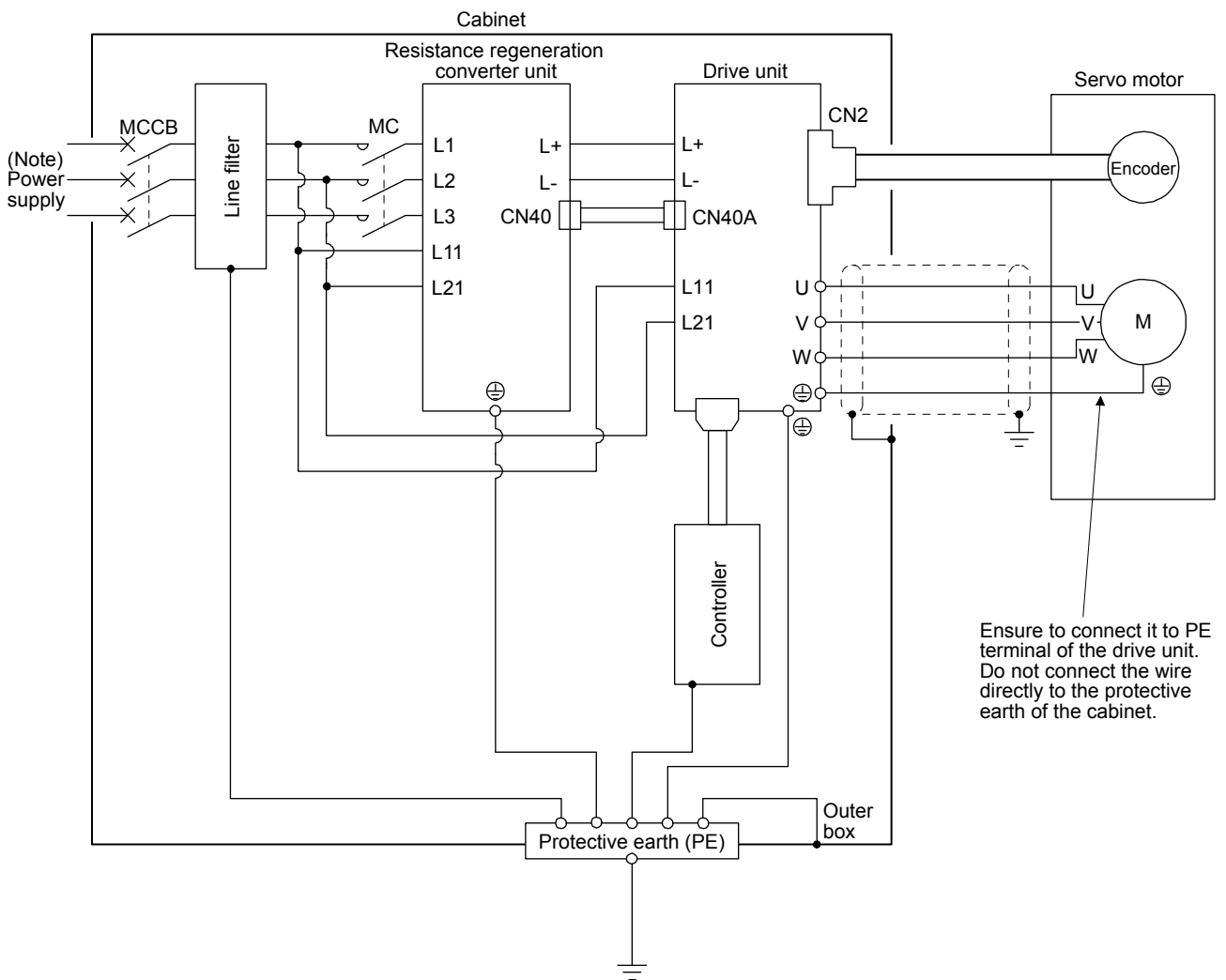

Note. Refer to section 1.4 for the power supply specifications.

4. MR-CR_ RESISTANCE REGENERATION CONVERTER UNIT

4.4 Startup

 **WARNING** ● Do not operate the switches with wet hands. Otherwise, it may cause an electric shock.

 **CAUTION**

- Before starting operation, check the parameters. Improper settings may cause some machines to operate unexpectedly.
- The heat sink of the resistance regeneration converter unit and the drive unit, the regenerative resistor, the servo motor, etc. may become hot while power is on or for some time after power-off. Take safety measures, such as providing covers, to avoid accidentally touching the parts (cables, etc.) by hand.
- During operation, never touch the rotor of the servo motor. Otherwise, it may cause injury.

The following items are the same as those of the MR-J4-_-(-RJ). For details of the items, refer to each chapter/section of the detailed explanation field. Read the corresponding section or chapter by replacing "servo amplifier" to "drive unit". "MR-J4-_B_" means "MR-J4-_B_-(-RJ) Servo Amplifier Instruction Manual". "MR-J4-_A_" means "MR-J4-_A_-(-RJ) Servo Amplifier Instruction Manual".

Model	Item	Detailed explanation
MR-J4-DU_B_(-RJ)	Switch setting and display of the servo amplifier	MR-J4-_B_ section 4.3
	Test operation	MR-J4-_B_ section 4.4
	Test operation mode	MR-J4-_B_ section 4.5
MR-J4-DU_A_(-RJ)	Display and operation section	MR-J4-_A_ section 4.5

4. MR-CR_ RESISTANCE REGENERATION CONVERTER UNIT

4.4.1 Switching power on for the first time

When switching the power on for the first time, follow this section to startup.

(1) Startup procedure

(a) MR-J4-DU_B_(-RJ)

"MR-J4-_B_" means "MR-J4-_B_(-RJ) Servo Amplifier Instruction Manual".

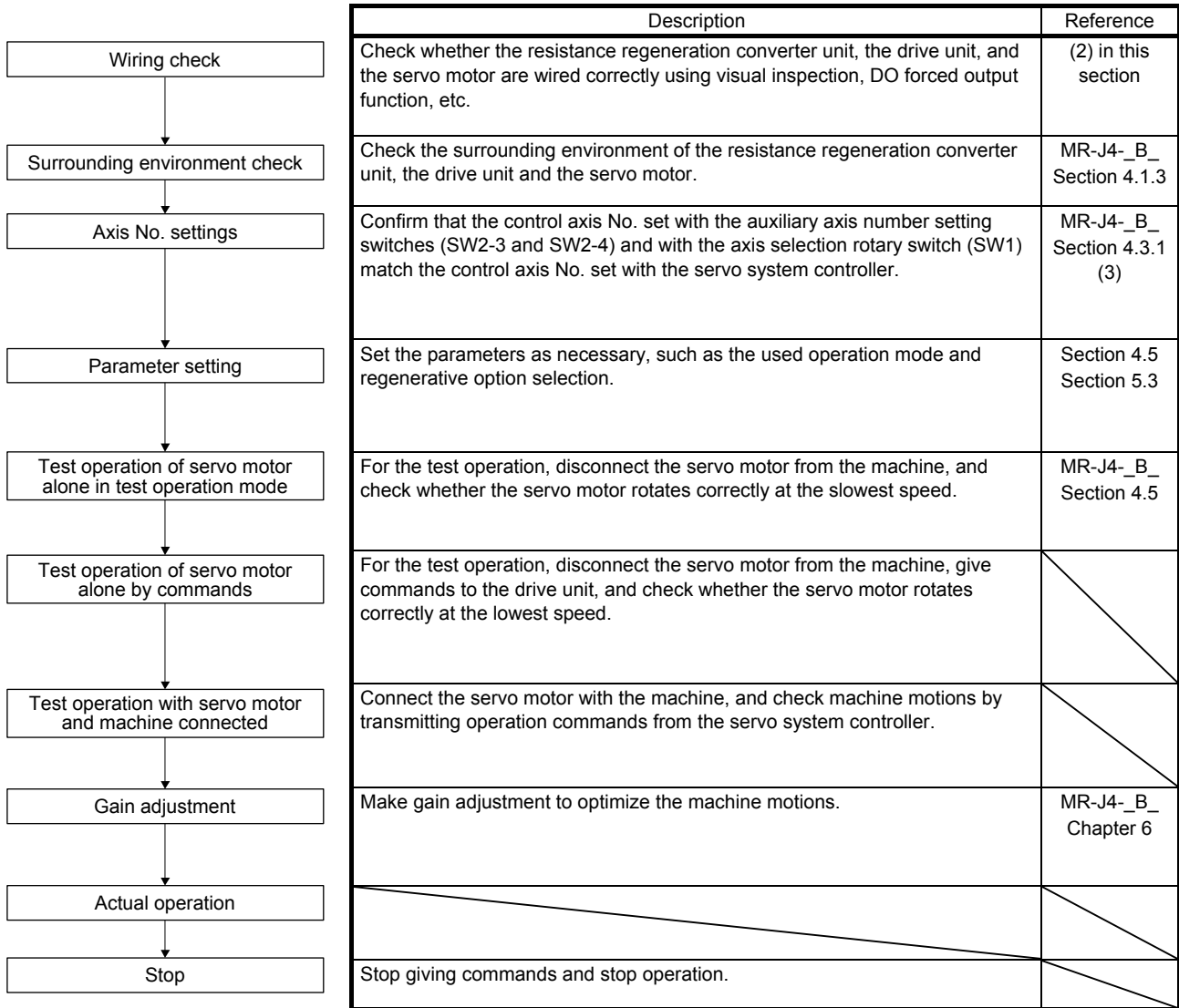

4. MR-CR_ RESISTANCE REGENERATION CONVERTER UNIT

(b) MR-J4-DU_A_(-RJ)

"MR-J4-_A_" means "MR-J4-_A_(-RJ) Servo Amplifier Instruction Manual".

	Description	Reference
Wiring check	Check whether the resistance regeneration converter unit, the drive unit, and the servo motor are wired correctly using visual inspection, DO forced output function, etc.	(2) in this section
Surrounding environment check	Check the surrounding environment of the resistance regeneration converter unit, the drive unit and the servo motor.	MR-J4-_A_ Section 4.1.3
Parameter setting	Set the parameters as necessary, such as the used operation mode and regenerative option selection.	Section 4.5
Test operation of servo motor alone in test operation mode	For the test operation, disconnect the servo motor from the machine, and check whether the servo motor rotates correctly at the slowest speed.	MR-J4-_A_ Section 4.2.3 Section 4.3.3 Section 4.4.3
Test operation of servo motor alone by commands	For the test operation, disconnect the servo motor from the machine, give commands to the drive unit, and check whether the servo motor rotates correctly at the lowest speed.	
Test operation with servo motor and machine connected	Connect the servo motor with the machine, and check machine motions by transmitting operation commands from the controller.	
Gain adjustment	Make gain adjustment to optimize the machine motions.	MR-J4-_A_ Chapter 6
Actual operation		
Stop	Stop giving commands and stop operation.	

4. MR-CR_ RESISTANCE REGENERATION CONVERTER UNIT

(2) Wiring check

(a) Power supply system wiring

Before turning on the power supplies of the main circuit and the control circuit, check the following items.

1) Power supply system wiring

- The power supplied to the resistance regeneration converter unit power input terminals (L1/L2/L3/L11/L21) and the drive unit power input terminals (L11/L21) should satisfy the defined specifications. (Refer to section 1.4.)
- When magnetic contactor drive output is enabled, the magnetic contactor control connector (CNP1) should be connected to the coil of the magnetic contactor.
- When the power factor improving DC reactor is not used, P1 and P2 in the resistance regeneration converter unit should be connected.

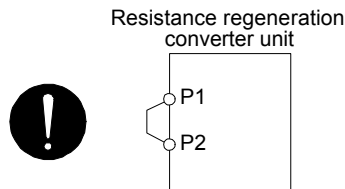

2) Connection of drive unit and servo motor

- The drive unit power outputs (U/V/W) should match in phase with the servo motor power input terminals (U/V/W).

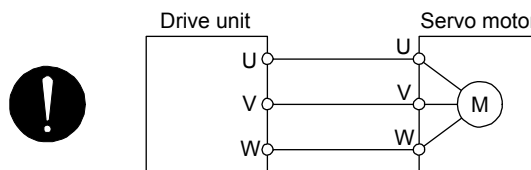

- The power supplied to the resistance regeneration converter unit should not be connected to the drive unit power outputs (U/V/W). Doing so will fail the connected drive unit and servo motor.

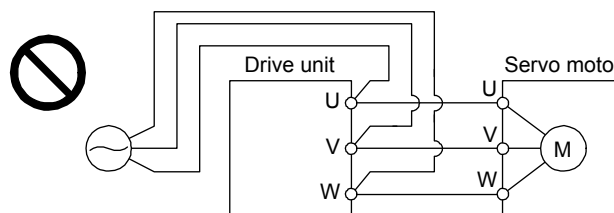

- The grounding terminal of the servo motor is connected to the PE terminal of the drive unit.

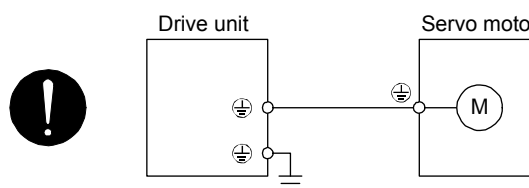

- The CN2 connector of the drive unit should be connected to the encoder of the servo motor securely by using the encoder cable.

4. MR-CR_ RESISTANCE REGENERATION CONVERTER UNIT

- 3) When using options and peripheral equipment
 - a) When using a regenerative option
 - The regenerative option should be connected to P+ and C terminals of the resistance regeneration converter unit.
 - A twisted wire should be used. (Refer to section 8.2.4.)
 - b) When using a brake unit
 - The brake unit should be connected to L+ and L- terminals of TE2-1 of the resistance regeneration converter unit. (Refer to section 8.11.3.)
 - A twisted wire should be used for the wiring over 5 m and equal to or less than 10 m when the brake unit is used. (Refer to section 8.11.3.)
 - c) The power factor improving DC reactor should be connected between P1 and P2 of the resistance regeneration converter unit. (Refer to section 8.6.)

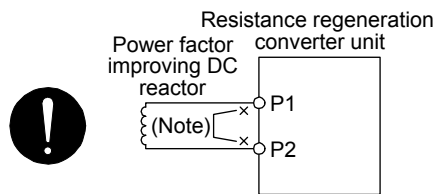

Note. Always disconnect wiring between P1 and P2.

- (b) I/O signal wiring
 - 1) Resistance regeneration converter unit
 - a) The I/O signals should be connected correctly.

Use DO forced output to forcibly turn on/off the pins of the CN1 connector. You can use this function to check the wiring. In this case, turn on the control circuit power supply only.

For details of I/O signal connection, refer to section 4.3.1 (2). For details of DO forced output, refer to section 4.4.3 (4) (c).
 - b) A voltage exceeding 24 V DC is not applied to the pins of the CN1 connector.
 - c) Between plate and DOCOM of the CN1 connector should not be shorted.

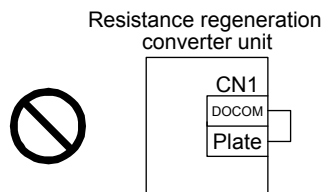

4. MR-CR_ RESISTANCE REGENERATION CONVERTER UNIT

2) Drive unit

a) MR-J4-DU_A_(-RJ)

- The I/O signals should be connected correctly.

Use DO forced output to forcibly turn on/off the pins of the CN1 connector. You can use this function to check the wiring. In this case, turn on the control circuit power supply only.

For details of I/O signal connection, refer to section 3.2 of "MR-J4-_A_(-RJ) Servo Amplifier Instruction Manual". For details of DO forced output, refer to section 4.5.8 of "MR-J4-_A_(-RJ) Servo Amplifier Instruction Manual".

- A voltage exceeding 24 V DC is not applied to the pins of the CN1 connector.
- Between plate and DOCOM of the CN1 connector should not be shorted.

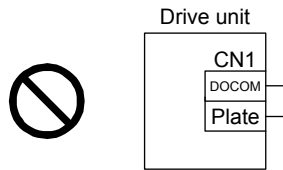

b) MR-J4-DU_B_(-RJ)

- The I/O signals should be connected correctly.

Use DO forced output to forcibly turn on/off the pins of the CN3 connector. You can use this function to check the wiring. In this case, turn on the control circuit power supply only.

For details of I/O signal connection, refer to section 3.2 of "MR-J4-_B_(-RJ) Servo Amplifier Instruction Manual". For details of DO forced output, refer to section 4.5.1 of "MR-J4-_B_(-RJ) Servo Amplifier Instruction Manual".

- A voltage exceeding 24 V DC is not applied to the pins of the CN3 connector.
- Between plate and DOCOM of the CN3 connector should not be shorted.

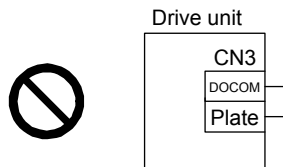

4. MR-CR_ RESISTANCE REGENERATION CONVERTER UNIT

4.4.2 Startup

(1) MR-J4-DU_A_(-RJ)

Startup of the MR-J4-DU_A_(-RJ) is the same as that of the MR-J4-_A_(-RJ). For details, refer to section 4.2 to 4.4 of "MR-J4-_A_(-RJ) Servo Amplifier Instruction Manual".

The resistance regeneration converter unit display shows "ron" (ready-on) at power-on.

When an error occurs or EM1 (Forced stop) is disabled in the resistance regeneration converter unit, the operation will stop.

(2) MR-J4-DU_B_(-RJ)

Startup of the MR-J4-DU_B_(-RJ) is the same as that of the MR-J4-_B_(-RJ). For details, refer to section 4.2 of "MR-J4-_B_(-RJ) Servo Amplifier Instruction Manual".

The resistance regeneration converter unit display shows "roF" (ready-off) at power-on.

When an error occurs or EM1 (Forced stop) is disabled in the resistance regeneration converter unit, the operation will stop.

4. MR-CR_ RESISTANCE REGENERATION CONVERTER UNIT

4.4.3 Display and operation section of the resistance regeneration converter unit

(1) Display flowchart

The resistance regeneration converter unit has the display (3-digit, 7-segment LED) and the operation section (4 pushbuttons) for resistance regeneration converter unit status display, alarm display, parameter setting, etc. Set the parameters before operation, diagnose an alarm, confirm external sequences, and/or confirm the operation status.

The following shows the operation procedure after power-on.

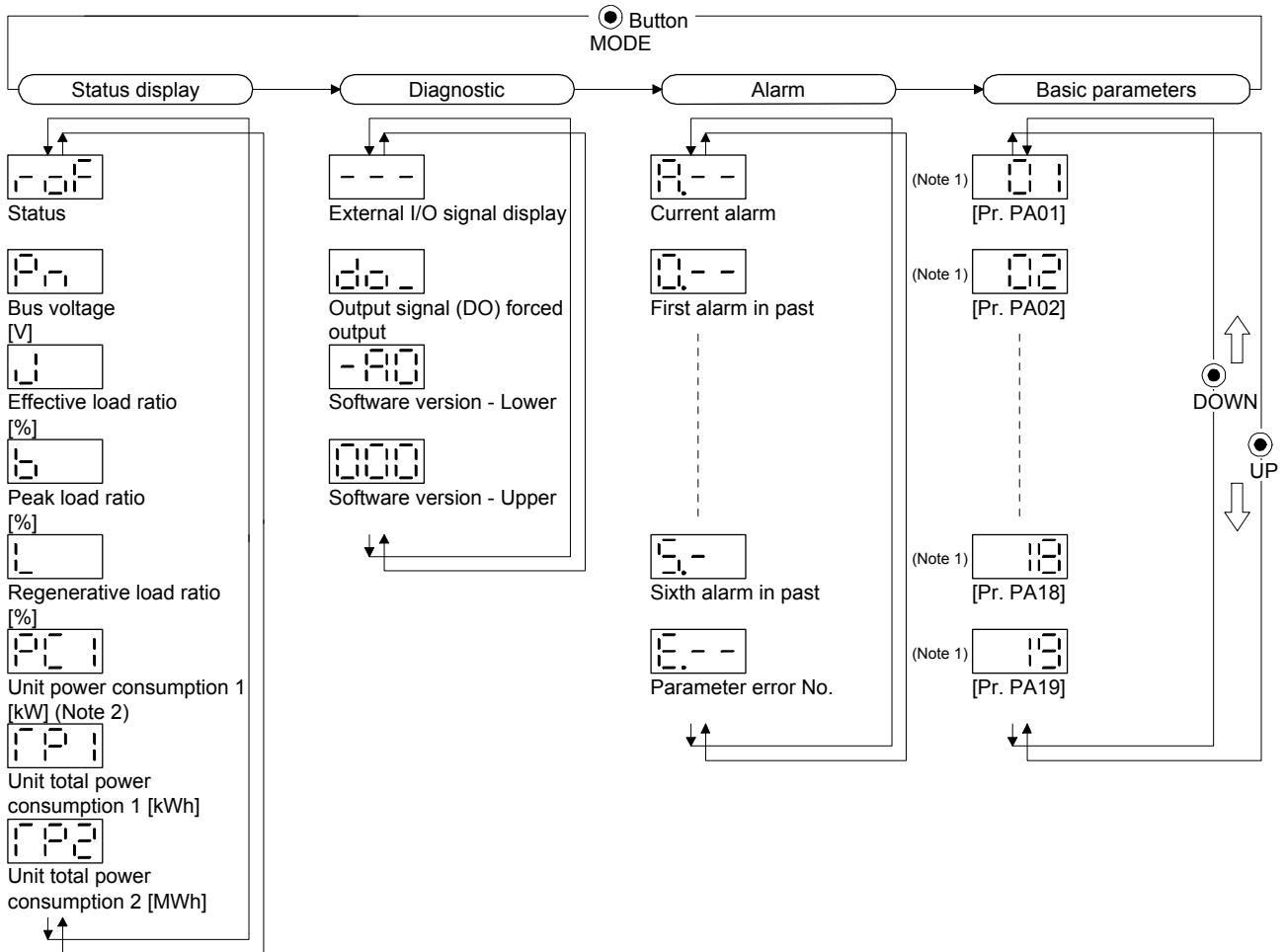

Note 1. When a parameter is selected, the parameter group and the parameter No. are displayed alternately. Refer to (6) in this section for details.

Note 2. The unit of unit power consumption 1 can be changed with [Pr. PA15].

4. MR-CR_ RESISTANCE REGENERATION CONVERTER UNIT

- (2) Display transition of the resistance regeneration converter unit/MR-J4-DU_B_(-RJ) drive unit
 The following shows the display transition of the resistance regeneration converter unit in which the protection coordination is enabled and MR-J4-DU_B_(-RJ) drive unit.

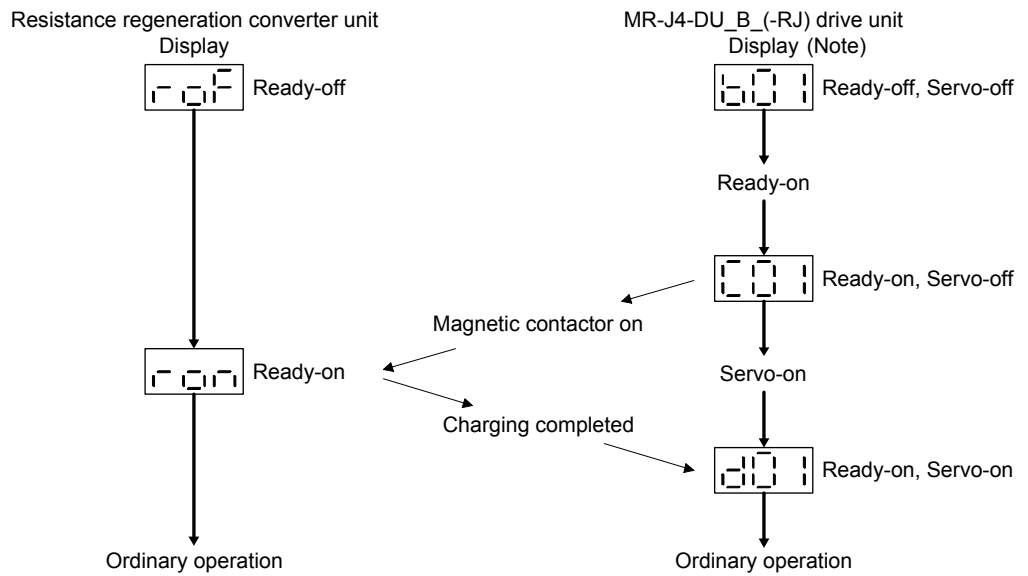

Note. For the detailed display transition of the drive unit, refer to "MR-J4-_B_(-RJ) Servo Amplifier Instruction Manual".

4. MR-CR_ RESISTANCE REGENERATION CONVERTER UNIT

(3) Status display mode

The resistance regeneration converter unit status during operation is shown on the 3-digit, 7-segment LED display. Press the "UP" or "DOWN" button to change display data as desired. When the required data is selected, the corresponding symbol is displayed. Press the "SET" button to display that data.

(a) Display examples

The following table shows the display examples.

Item	State	Displayed data
Status	Ready-off	roF
	Ready-on	ron
Bus voltage	300 [V]	300
Effective load ratio	67 [%]	67
Peak load ratio	95 [%]	95
Regenerative load ratio	90 [%]	90

(b) Status display list

The following table lists the resistance regeneration converter unit statuses that may be displayed.

Status display	Symbol	Unit	Description	Indication range
Status	Ready-off		Ready-off is displayed during initialization or alarm occurrence, in the external forced stop status, or when the bus voltage is not established.	roF
	Ready-on		Ready-on is displayed when the servo was switched on after completion of initialization and the resistance regeneration converter unit is ready to operate.	ron
Bus voltage	Pn	V	The bus voltage is displayed.	0 to 999
Effective load ratio	J	%	The effective load ratio in the past 15 s is displayed relative to the rated load of 100%.	0 to 300
Peak load ratio	b	%	The peak load ratio in the past 15 s is displayed relative to the rated load of 100%.	0 to 400
Regenerative load ratio	L	%	The ratio of regenerative power to permissible regenerative power is displayed in %.	0 to 300
Unit power consumption 1	PC1	kW (Note)	Unit power consumption is displayed by increment of 1 kW or 0.1 kW.	0 to 999
Unit total power consumption 1	TP1	kWh	Unit total power consumption is displayed by increment of 1 kWh.	0 to 999
Unit total power consumption 2	TP2	MWh	Unit total power consumption is displayed by increment of 1 MWh.	0 to 999

Note. The unit of unit power consumption 1 can be changed with [Pr. PA15].

4. MR-CR_ RESISTANCE REGENERATION CONVERTER UNIT

(4) Diagnostic mode
 (a) Diagnostic list

Name	Display	Description
External I/O signal display		Indicates the on/off status of external I/O signal. Refer to (3) (b) in this section for details.
Output signal (DO) forced output		Indicates that the digital output signal can be switched on/off forcibly. Refer to (3) (c) in this section for details.
Software version - Lower		Indicates the version of the software.
Software version - Upper		Indicates the system number of the software.

(b) External I/O signal display

The on/off states of the digital I/O signals connected to the resistance regeneration converter unit can be confirmed.

1) Operation

The following shows the display screen at power-on. Using the "MODE" button, display the diagnostic screen.

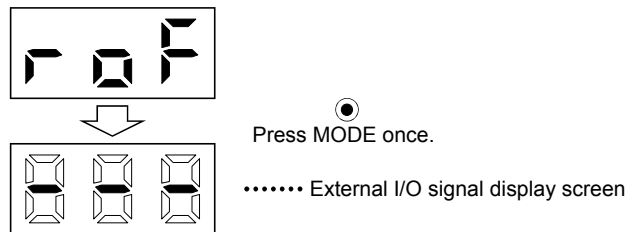

2) Display definition

The LED segment corresponding to the pin is lit to indicate on, and is extinguished to indicate off. The 7-segment LED segments and CN1 connector pins correspond as shown below.

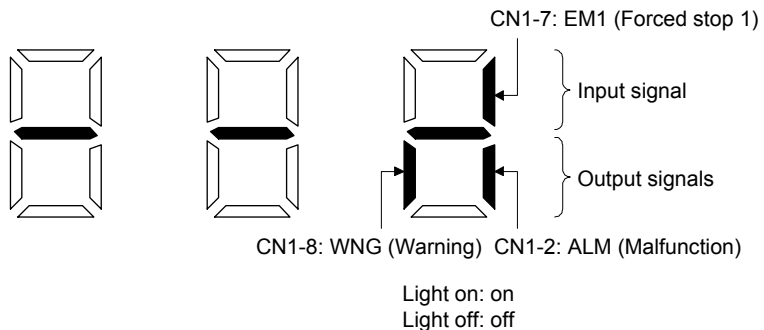

4. MR-CR_ RESISTANCE REGENERATION CONVERTER UNIT

(c) Output signal (DO) forced output

Output signals can be forcibly switched on/off independently of the resistance regeneration converter unit status. Use this function for checking output signal wiring, etc. The following shows the display screen at power-on.

When turning CN1-8 on and off

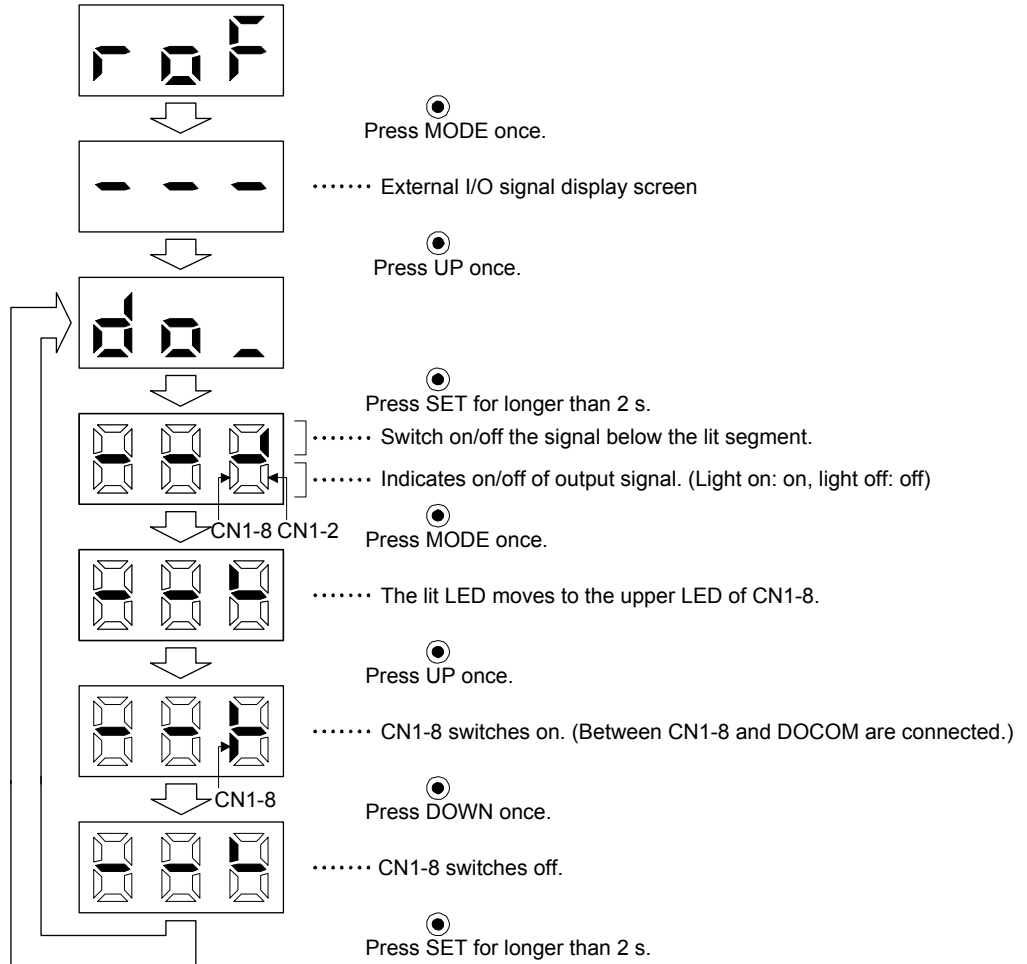

4. MR-CR_ RESISTANCE REGENERATION CONVERTER UNIT

(5) Alarm mode

The current alarm, past alarm history, and parameter error are displayed. The lower 2 digits on the display indicate the alarm number that has occurred or the parameter number in error.

Name	Display	Description
Current alarm		Indicates no occurrence of an alarm.
		Indicates that [AL. 33 Overvoltage] occurred. Blinks at alarm occurrence.
Alarm history		Indicates that the last alarm is [AL. 50 Overload 1].
		Indicates that the second alarm in the past is [AL. 33 Undervoltage].
		Indicates that the third alarm in the past is [AL. 10 Undervoltage].
		Indicates that the fourth alarm in the past is [AL. 10 Undervoltage].
		Indicates that the fifth alarm in the past is [AL. 10 Undervoltage].
		Indicates that the sixth alarm in the past is [AL. 50 Overload 1].
Parameter error No.		Indicates no occurrence of [AL. 37 Parameter error].
		Indicates that the data of [Pr. PA01 Regenerative option] is faulty.

4. MR-CR_ RESISTANCE REGENERATION CONVERTER UNIT

Functions at alarm occurrence

- (a) Any mode screen displays the current alarm.
- (b) Even during alarm occurrence, the other screen can be viewed by pressing the button in the operation area. At this time, the decimal point in the third digit remains blinking.
- (c) For any alarm, remove its cause and clear it in any of the following methods. (Refer to chapter 6 for the alarms that can be cleared.)
 - 1) Switch power off, then on.
 - 2) Press the "SET" button on the current alarm screen.
- (d) Use [Pr. PA09] to clear the alarm history.

(6) Parameter mode

POINT

- The display of the resistance regeneration converter unit has three digits. When a parameter No. is displayed, the parameter group and the parameter No. are displayed alternately.
For example, when [Pr. PA01] is displayed, "PA" and "01" are displayed alternately.

The following example shows how to select MR-RB137 in [Pr. PA01 Regenerative option] after power-on.

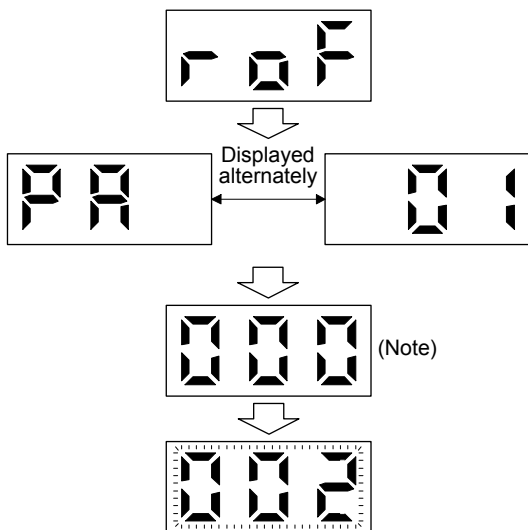

- Press MODE three times.
..... The parameter number is displayed.
For [Pr. PA01], "PA" and "01" are displayed alternately.
- Press UP or DOWN to change the number.
- Press MODE twice.
..... The set value of the specified parameter number blinks. In this case, the lower three digits of the setting value "0 0 0 0" are displayed.
- Press MODE once.
..... During blinking, the set value can be changed.
- Use UP or DOWN. When a negative value is set, the decimal point blinks.
(_ _ _ 2: MR-RB137 (3 pcs.) are used.)
- Press SET to enter.

Note. When the lower three digits of the four digits are displayed, pressing the "MODE" button displays the fourth digit. However, do not change the setting of the fourth digit. Pressing the "MODE" button again resets the display to the lower three digits.

To shift to the next parameter, press the "UP" or "DOWN" button.

When changing the [Pr. PA01] setting, change its setting value, and then cycle the power to enable the new value.

4. MR-CR_ RESISTANCE REGENERATION CONVERTER UNIT

4.5 Parameters



CAUTION

- Never make a drastic adjustment or change to the parameter values as doing so will make the operation unstable.
- Do not change the parameter settings as described below. Doing so may cause an unexpected condition, such as failing to start up the resistance regeneration converter unit.
 - Changing the values of the parameters for manufacturer setting.
 - Setting a value out of the range.
 - Changing the fixed values in the digits of a parameter.

4.5.1 Parameter list

POINT

- To enable a parameter whose symbol is preceded by *, cycle the power after setting it.

No.	Symbol	Name	Initial value	Unit
PA01	*REG	Regenerative option	0000h	
PA02	*MCC	Magnetic contactor drive output selection	0001h	
PA03		For manufacturer setting	0001h	
PA04			0	
PA05			100	
PA06			0	
PA07			100	
PA08	*DMD	Status display selection	0000h	
PA09	*BPS	Alarm history clear	0000h	
PA10		For manufacturer setting	0	
PA11			0000h	
PA12	*DIF	Input filter setting	0002h	
PA13		For manufacturer setting	0000h	
PA14			0000h	
PA15	AOP3	Function selection A-3	0000h	
PA16		For manufacturer setting	0000h	
PA17	*AOP5	Function selection A-5	0001h	
PA18	CVAT	SEMI-F47 function - Instantaneous power failure detection time	200	[ms]
PA19		For manufacturer setting	0000h	

4. MR-CR_ RESISTANCE REGENERATION CONVERTER UNIT

4.5.2 Detailed list of parameters

POINT
● Set a value to each "x" in the "Setting digit" columns.

No./symbol/ name	Setting digit	Function	Initial value [unit]
PA01 *REG Regenerative option	__ x x	Regenerative option Select a regenerative option. Incorrect setting will trigger [AL. 37 Parameter error]. 00: Regenerative option is not used. When using the FR-BU2-(H) brake unit, select the value. 01: MR-RB139 02: MR-RB137 (3 pcs.) 13: MR-RB137-4 14: MR-RB13V-4 (3 pcs.)	00h
	_ x _ _	For manufacturer setting	0h
	x _ _ _		0h
PA02 *MCC Magnetic contactor drive output selection	___ x	Magnetic contactor drive output selection Select the magnetic contactor drive output. 0: Disabled 1: Enabled	1h
	_ _ x _	For manufacturer setting	0h
	_ x _ _		0h
	x _ _ _		0h
PA08 *DMD Status display selection	___ x	Status display selection Select a status display shown at power-on. 0: Status 1: Bus voltage 2: Effective load ratio 3: Peak load ratio 4: Regenerative load ratio 5: Unit power consumption 1 6: Unit total power consumption 1 7: Unit total power consumption 2	0h
	_ _ x _	For manufacturer setting	0h
	_ x _ _		0h
	x _ _ _		0h
PA09 *BPS Alarm history clear	___ x	Alarm history clear Used to clear the alarm history. 0: Disabled 1: Enabled When you select "Enabled", the alarm history will be cleared at next power-on. After the alarm history is cleared, the setting is automatically disabled.	0h
	_ _ x _	For manufacturer setting	0h
	_ x _ _		0h
	x _ _ _		0h

4. MR-CR_ RESISTANCE REGENERATION CONVERTER UNIT

No./symbol/ name	Setting digit	Function	Initial value [unit]
PA12 *DIF Input filter setting	___x	Input filter setting Select the input filter. If external input signal causes chattering due to noise, etc., input filter is used to suppress it. 0: None 1: 1.777 [ms] 2: 3.555 [ms] 3: 5.333 [ms]	2h
	__x_	For manufacturer setting	0h
	_x__		0h
	x___		0h
PA15 AOP3 Function selection A-3	___x	Selection of unit power consumption display unit 0: increment of 1 kW 1: increment of 0.1 kW	0h
	__x_	For manufacturer setting	0h
	_x__		0h
	x___		0h
PA17 *AOP5 Function selection A-5	The [Pr. PA17 SEMI-F47 function selection] and [Pr. PA18 SEMI-F47 function - Instantaneous power failure detection time] settings of the resistance regeneration converter unit must be the same as [Pr. PA20 SEMI-F47 function selection] and [Pr. PF25 SEMI-F47 function - Instantaneous power failure detection time] settings of the drive unit.		
	___x	[AL. 10 Undervoltage] detection method selection Set this parameter when [AL. 10] occurs due to distorted power supply voltage waveform. 0: [AL. 10] not occurrence 1: [AL. 10] occurrence	1h
	__x_	SEMI-F47 function selection 0: Disabled 1: Enabled Selecting "1" enables to avoid triggering [AL. 10 Undervoltage] using the electrical energy charged in the capacitor in case that an instantaneous power failure occurs during operation. In [Pr. PA18 SEMI-F47 function - Instantaneous power failure detection time], set the time until the occurrence of [AL. 10 Undervoltage].	0h
	_x__	For manufacturer setting	0h
x___	0h		
PA18 CVAT SEMI-F47 function - Instanta- neous power failure detection time	The [Pr. PA17 SEMI-F47 function selection] and [Pr. PA18 SEMI-F47 function - Instantaneous power failure detection time] settings of the resistance regeneration converter unit must be the same as [Pr. PA20 SEMI-F47 function selection] and [Pr. PF25 SEMI-F47 function - Instantaneous power failure detection time] settings of the drive unit.		
		Set the time until the occurrence of [AL. 10 Undervoltage]. To disable the parameter setting value, select "Disabled (_ _ 0 _)" of "SEMI-F47 function selection" in [Pr. PA17]. Setting range: 30 to 200	200 [ms]

4. MR-CR_ RESISTANCE REGENERATION CONVERTER UNIT

4.6 Characteristics

4.6.1 Overload protection characteristics

(1) Converter unit

An electronic thermal is built in the resistance regeneration converter unit to protect the resistance regeneration converter unit from overloads.

[AL. 50 Overload 1] occurs if overload operation performed is above the electronic thermal protection curve shown in the following figure. [AL. 51 Overload 2] occurs if the maximum current is applied continuously for several seconds due to machine collision, etc. [AL. 51 Overload 2] occurs if the maximum current is applied continuously for several seconds due to machine collision, etc. Use the equipment on the left-side area of the graph.

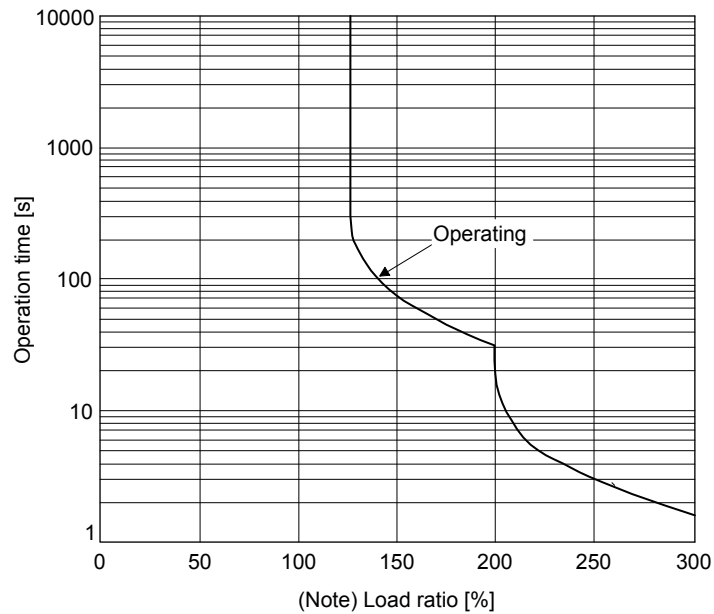

Note. Load ratio 100% indicates the rated output of the resistance regeneration converter unit. Refer to section 1.4.2 for rated output.

4. MR-CR_ RESISTANCE REGENERATION CONVERTER UNIT

4.6.2 Power supply capacity and generated loss

(1) Generated heat of the resistance regeneration converter unit/drive unit

The following table indicates the generated loss under rated load and the power supply capacity per combination of the resistance regeneration converter unit and drive unit.

Resistance regeneration converter unit	Drive unit	Power supply capacity [kVA]		Drive unit-generated heat [W] (Note)			Area required for heat dissipation [m ²]
		Power factor improving DC reactor is not used	Power factor improving DC reactor is used	At rated output	At rated output [Generated heat in the cabinet when cooled outside the cabinet]	With servo-off	
MR-CR55K	MR-J4-DU30K_(-RJ)	48	40	1350 (900 + 450)	470	60 (30 + 30)	27.0
	MR-J4-DU37K_(-RJ)	59	49	1550 (1000 + 550)	550		31.0
MR-CR55K4	MR-J4-DU30K_4(-RJ)	48	40	1070 (790 + 280)	390		21.4
	MR-J4-DU37K_4(-RJ)	59	49	1252 (910 + 342)	470		25.1
	MR-J4-DU45K_4(-RJ)	71	59	1580 (1110 + 470)	550		31.6
	MR-J4-DU55K_4(-RJ)	87	72	1940 (1440 + 500)	650		38.8

Note. The heat generated by the drive unit is indicated in the left term within the parentheses, and the heat generated by the resistance regeneration converter unit in the right term.

When the servo motors are run at less than the rated speed, the power supply equipment capacity is lower than the value in the table but the heat generated does not change.

Since the servo motor requires 2 times to 2.5 times greater instantaneous power for acceleration, use the power supply which ensures that the voltage lies within the permissible voltage fluctuation at the main circuit power supply terminals (L1/L2/L3) of the resistance regeneration converter unit. The power supply equipment capacity changes with the power supply impedance.

The actually generated heat falls within the ranges at rated output and at servo-off according to the frequencies of use during operation. When designing an enclosed cabinet, use the values in the table, considering the worst operating conditions. The generated heat in this table does not include heat produced during regeneration.

4. MR-CR_ RESISTANCE REGENERATION CONVERTER UNIT

(2) Heat dissipation area for an enclosed type cabinet

The enclosed type cabinet (hereafter called the cabinet) which will contain the resistance regeneration converter unit and drive unit should be designed to ensure that its temperature rise is within +10 °C at the ambient temperature of 40 °C. (With an approximately 5 °C safety margin, the system should operate within a maximum 55 °C limit.) The necessary cabinet heat dissipation area can be calculated by next equation.

$$A = \frac{P}{K \cdot \Delta T}$$

A: Heat dissipation area [m²]

P: Loss generated in the cabinet [W]

ΔT: Difference between internal and ambient temperatures [°C]

K: Heat dissipation coefficient [5 to 6]

When calculating the heat dissipation area with the equation, assume that P is the sum of all losses generated in the cabinet. Refer to (1) in this section for the generated heat of the resistance regeneration converter unit/drive unit. "A" indicates the effective area for heat dissipation, but if the cabinet is directly installed on an insulated wall, that extra amount must be added to the cabinet's surface area. The required heat dissipation area will vary with the conditions in the cabinet. If convection in the cabinet is poor and heat builds up, effective heat dissipation will not be possible. Therefore, arrangement of the equipment in the cabinet and the use of a cooling fan should be considered. The above (1) in this section lists the cabinet dissipation area (guideline) when this unit and drive unit are operated at the ambient temperature of 40 °C under rated load.

When air flows along the outer wall of the cabinet, effective heat exchange will be possible, because the temperature slope inside and outside the cabinet will be steeper.

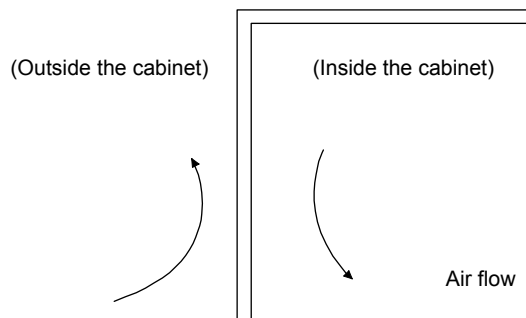

4. MR-CR_ RESISTANCE REGENERATION CONVERTER UNIT

4.6.3 Inrush currents at power-on of main circuit/control circuit

POINT
<ul style="list-style-type: none"> ● The inrush current values can change depending on frequency of turning on/off the power and ambient temperature.

Since large inrush currents flow in the power supplies, always use molded-case circuit breakers and magnetic contactors. (Refer to section 8.5.)

When circuit protectors are used, it is recommended that the inertia delay type, which is not tripped by an inrush current, be used.

When the converter unit and drive unit are connected by passing wiring, the total inrush current of them flow.

(1) 200 V class

The following table indicates the inrush currents (reference data) that will flow when 240 V AC is applied.

Resistance regeneration converter unit	Inrush currents (A_{0-P})	
	Main circuit power supply (L1/L2/L3)	Control circuit power supply (L11/L21)
MR-CR55K	154 A (Attenuated to approx. 20 A in 150 ms)	31 A (attenuated to approx. 2 A in 60 ms)

(2) 400 V class

The following table indicates the inrush currents (reference data) that will flow when 480 V AC is applied.

Resistance regeneration converter unit	Inrush currents (A_{0-P})	
	Main circuit power supply (L1/L2/L3)	Control circuit power supply (L11/L21)
MR-CR55K4	305 A (attenuated to approx. 20 A in 70 ms)	27 A (attenuated to approx. 2 A in 45 ms)

5. MR-J4-DU_(-RJ) DRIVE UNIT

5. MR-J4-DU_(-RJ) DRIVE UNIT

5.1 Structure (Parts identification)

POINT

- The drive unit is shown with the terminal cover open. For opening or closing of the terminal cover, refer to section 4.2.2.

5. MR-J4-DU_(-RJ) DRIVE UNIT

5.1.1 MR-J4-DU_B_(-RJ)

"MR-J4-_B_" means "MR-J4-_B_(-RJ) Servo Amplifier Instruction Manual".

(1) 200 V class

(a) MR-J4-DU900B(-RJ)/MR-J4-DU11KB(-RJ)

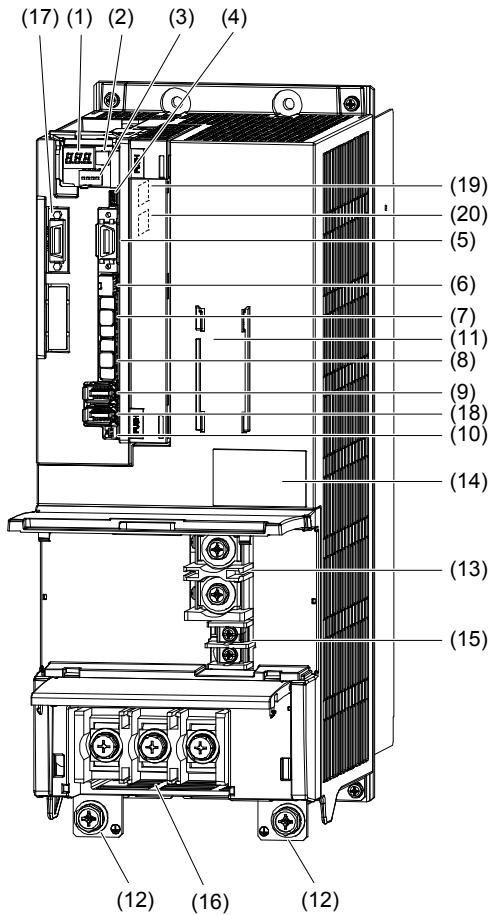

No.	Name/Application	Detailed explanation
(1)	Display The 3-digit, 7-segment LED display shows the drive unit status and the alarm number.	MR-J4-_B_ Section 4.3
(2)	Axis selection rotary switch (SW1) Set the axis No. of the drive unit.	
(3)	Control axis setting switch (SW2) The test operation switch, the disabling control axis switch, and the auxiliary axis number setting switch are available.	
(4)	USB communication connector (CN5) Connect with the personal computer.	MR-J4-_B_ Section 11.7
(5)	I/O signal connector (CN3) Connect digital I/O signals.	MR-J4-_B_ Section 3.2 Section 3.4
(6)	STO input signal connector (CN8) Connect the MR-J3-D05 safety logic unit and external safety relay.	MR-J4-_B_ Chapter 13 App. 5
(7)	SSCNET III cable connector (CN1A) Connect a servo system controller or the previous axis servo amplifier (drive unit).	MR-J4-_B_ Section 3.2 Section 3.4
(8)	SSCNET III cable connector (CN1B) Connect the next axis servo amplifier (drive unit). For the final axis, put a cap.	
(9) (Note 2)	Encoder connector (CN2) Connect the servo motor encoder or external encoder.	MR-J4-_B_ Section 3.4 "Servo Motor Instruction Manual (Vol. 3)" Section 1.1
(10)	Battery connector (CN4) Connect the battery for absolute position data backup.	MR-J4-_B_ Chapter 12
(11)	Battery holder Install the battery for absolute position data backup.	MR-J4-_B_ Section 12.2
(12)	Protective earth (PE) terminal	Section 5.2.1
(13)	L+/L- terminal (TE2-1) Connect with the L+ and L- terminals of the converter unit or another drive unit by bus bars.	
(14)	Rating plate	Section 1.2
(15)	Control circuit terminal L11/L21 (TE3) Connect to the control circuit power supply.	Section 5.2.1
(16)	Servo motor power output terminal (TE1) Connect the servo motor.	
(17)	Protection coordination connector (CN40A) For the drive unit adjacent to the converter unit, connect with the CN4 of the power regeneration converter unit or the CN40 of the resistance regeneration converter unit.	
(18) (Note 1)	External encoder connector (CN2L) (Note 2) Connect the external encoder.	Section 5.2.2 "Linear Encoder Instruction Manual" Section 1.1
(19)	Optional unit connector (CN7) This connector is attached on the MR-J4-DU_B_-RJ drive unit. Connect an optional unit. The MR-J4-DU_B_ drive unit does not have this connector.	
(20)	Optional unit connector (CN9) This connector is attached on the MR-J4-DU_B_-RJ drive unit. Connect an optional unit. The MR-J4-DU_B_ drive unit does not have this connector.	

- Note 1. This is for the MR-J4-DU_B_-RJ drive unit. The MR-J4-DU_B_ drive unit does not have the CN2L connector.
- Note 2. "External encoder" is a term for the linear encoder used in the linear servo system, the load-side encoder used in the fully closed loop system, and the scale measurement encoder used with the scale measurement function in this manual.

5. MR-J4-DU_(-RJ) DRIVE UNIT

(b) MR-J4-DU15KB(-RJ)/MR-J4-DU22KB(-RJ)

The broken line area is the same as MR-J4-DU900B(-RJ)/MR-J4-DU11KB(-RJ).

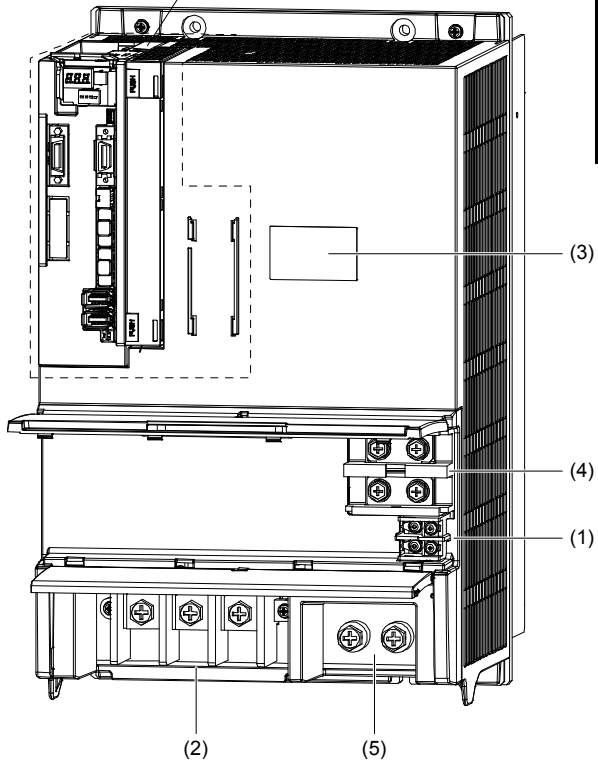

No.	Name/Application	Detailed explanation
(1)	Control circuit terminal L11/L21 (TE3) Connect to the control circuit power supply.	Section 5.2.1
(2)	Servo motor power output terminal (TE1) Connect the servo motor.	
(3)	Rating plate	Section 1.2
(4)	L+/L- terminal (TE2-1) Connect with the L+ and L- terminals of the converter unit or another drive unit by bus bars.	Section 5.2.1
(5)	Protective earth (PE) terminal	Section 5.2.1

5. MR-J4-DU_(-RJ) DRIVE UNIT

(c) MR-J4-DU30KB(-RJ)/MR-J4-DU37KB(-RJ)

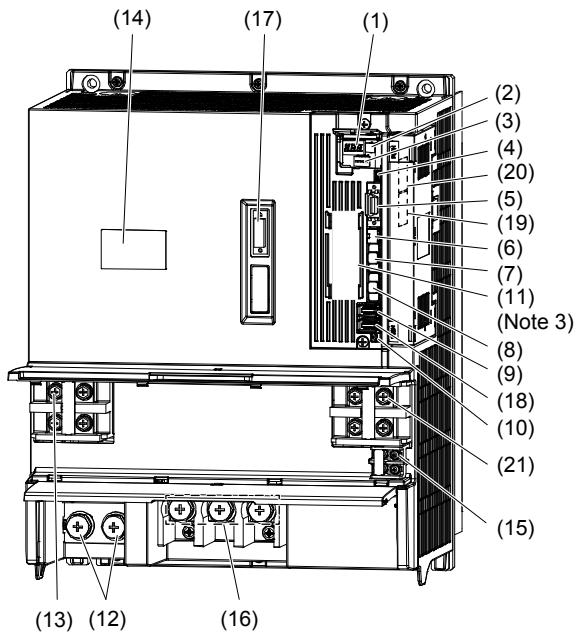

No.	Name/Application	Detailed explanation
(1)	Display The 3-digit, 7-segment LED display shows the drive unit status and the alarm number.	MR-J4-_B_ Section 4.3
(2)	Axis selection rotary switch (SW1) Used to set the axis No. of the drive unit.	
(3)	Control axis setting switch (SW2) The test operation switch, the disabling control axis switch, and the auxiliary axis number setting switch are available.	
(4)	USB communication connector (CN5) Used to connect the personal computer.	MR-J4-_B_ Section 11.7
(5)	I/O signal connector (CN3) Used to connect digital I/O signals.	MR-J4-_B_ Section 3.2 Section 3.4
(6)	STO input signal connector (CN8) Used to connect the MR-J3-D05 safety logic unit and external safety relay.	MR-J4-_B_ Chapter 13 App. 5
(7)	SSCNET III cable connector (CN1A) Used to connect the servo system controller or the previous axis servo amplifier (drive unit).	MR-J4-_B_ Section 3.2 Section 3.4
(8)	SSCNET III cable connector (CN1B) Used to connect the next axis servo amplifier (drive unit). For the final axis, put a cap.	
(9) (Note 2)	Encoder connector (CN2) Used to connect the servo motor encoder or external encoder.	MR-J4-_B_ Section 3.4 "Servo Motor Instruction Manual (Vol. 3)" Section 1.1
(10)	Battery connector (CN4) Used to connect the battery for absolute position data backup.	MR-J4-_B_ Chapter 12
(11)	Battery holder Used to house the battery for absolute position data backup.	MR-J4-_B_ Section 12.2
(12)	Protective earth (PE) terminal Grounding terminal	Section 5.2.1
(13)	L+/L- terminal (TE2-1) Connect with the L+ and L- terminals of the converter unit or another drive unit by bus bars.	
(14)	Rating plate	Section 1.2
(15)	Control circuit terminal L11/L21 (TE3) Used to connect the control circuit power supply.	Section 5.2.1
(16)	Servo motor power output terminal (TE1) Used to connect the servo motor.	
(17)	Protection coordination connector (CN40A) For the drive unit adjacent to the converter unit, connect with the CN4 of the power regeneration converter unit or the CN40 of the resistance regeneration converter unit.	
(18) (Note 1)	External encoder connector (CN2L) (Note 2) Used to connect the external encoder.	Section 5.2.2 "Linear Encoder Instruction Manual" Section 1.1
(19)	Optional unit connector (CN7) This connector is attached on the MR-J4-DU_B_-RJ drive unit. Connect an optional unit. The MR-J4-DU_B_ drive unit does not have this connector.	
(20)	Optional unit connector (CN9) This connector is attached on the MR-J4-DU_B_-RJ drive unit. Connect an optional unit. The MR-J4-DU_B_ drive unit does not have this connector.	
(21)	L+/L- terminal (TE2-2) Connect with the L+ and L- terminals of another drive unit by bus bars.	Section 5.2.1

- Note 1. This is for the MR-J4-DU_B_-RJ drive unit. The MR-J4-DU_B_ drive unit does not have the CN2L connector.
- Note 2. "External encoder" is a term for the load-side encoder used in the fully closed loop system and the scale measurement encoder used with the scale measurement function in this manual.
- Note 3. Lines for slots around the battery holder are omitted from the illustration.

5. MR-J4-DU_(-RJ) DRIVE UNIT

(2) 400 V class

(a) MR-J4-DU900B4(-RJ)/MR-J4-DU11KB4(-RJ)

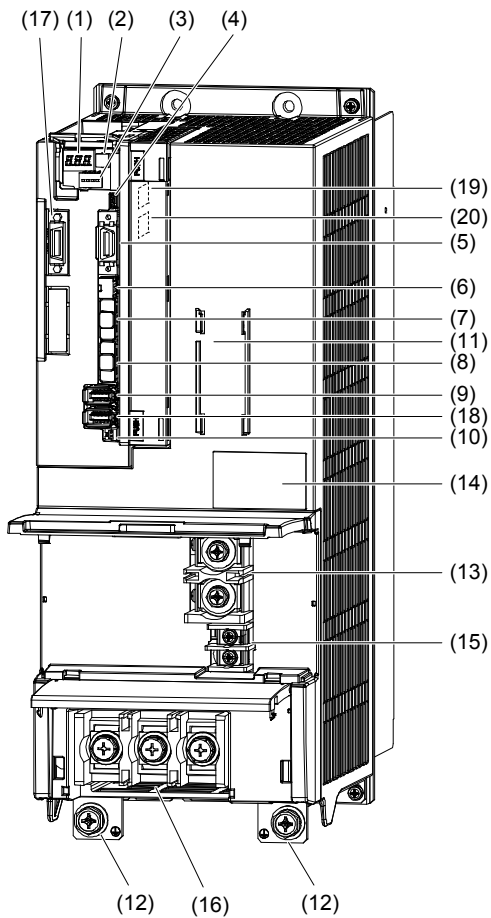

No.	Name/Application	Detailed explanation
(1)	Display The 3-digit, 7-segment LED display shows the drive unit status and the alarm number.	MR-J4-_B_ Section 4.3
(2)	Axis selection rotary switch (SW1) Set the axis No. of the drive unit.	
(3)	Control axis setting switch (SW2) The test operation switch, the disabling control axis switch, and the auxiliary axis number setting switch are available.	
(4)	USB communication connector (CN5) Connect with the personal computer.	MR-J4-_B_ Section 11.7
(5)	I/O signal connector (CN3) Connect digital I/O signals.	MR-J4-_B_ Section 3.2 Section 3.4
(6)	STO input signal connector (CN8) Connect the MR-J3-D05 safety logic unit and external safety relay.	MR-J4-_B_ Chapter 13 App. 5
(7)	SSCNET III cable connector (CN1A) Connect a servo system controller or the previous axis servo amplifier (drive unit).	MR-J4-_B_ Section 3.2 Section 3.4
(8)	SSCNET III cable connector (CN1B) Connect the next axis servo amplifier (drive unit). For the final axis, put a cap.	
(9) (Note 2)	Encoder connector (CN2) Connect the servo motor encoder or external encoder.	MR-J4-_B_ Section 3.4 "Servo Motor Instruction Manual (Vol. 3)" Section 1.1
(10)	Battery connector (CN4) Connect the battery for absolute position data backup.	MR-J4-_B_ Chapter 12
(11)	Battery holder Install the battery for absolute position data backup.	MR-J4-_B_ Section 12.2
(12)	Protective earth (PE) terminal	Section 5.2.1
(13)	L+/L- terminal (TE2-1) Connect with the L+ and L- terminals of the converter unit or another drive unit by bus bars.	
(14)	Rating plate	Section 1.2
(15)	Control circuit terminal L11/L21 (TE3) Connect to the control circuit power supply.	Section 5.2.1
(16)	Servo motor power output terminal (TE1) Connect the servo motor.	
(17)	Protection coordination connector (CN40A) For the drive unit adjacent to the converter unit, connect with the CN4 of the power regeneration converter unit or the CN40 of the resistance regeneration converter unit.	
(18) (Note 1)	External encoder connector (CN2L) (Note 2) Connect the external encoder.	Section 5.2.2 "Linear Encoder Instruction Manual" Section 1.1
(19)	Optional unit connector (CN7) This connector is attached on the MR-J4-DU_B4-RJ drive unit. Connect an optional unit. The MR-J4-DU_B4 drive unit does not have this connector.	
(20)	Optional unit connector (CN9) This connector is attached on the MR-J4-DU_B4-RJ drive unit. Connect an optional unit. The MR-J4-DU_B4 drive unit does not have this connector.	

Note 1. This is for the MR-J4-DU_B4-RJ drive unit. The MR-J4-DU_B4 drive unit does not have the CN2L connector.

Note 2. "External encoder" is a term for the load-side encoder used in the fully closed loop system and the scale measurement encoder used with the scale measurement function in this manual.

5. MR-J4-DU_(-RJ) DRIVE UNIT

(b) MR-J4-DU15KB4(-RJ)/MR-J4-DU22KB4(-RJ)

The broken line area is the same as MR-J4-DU900B4(-RJ)/MR-J4-DU11KB4(-RJ).

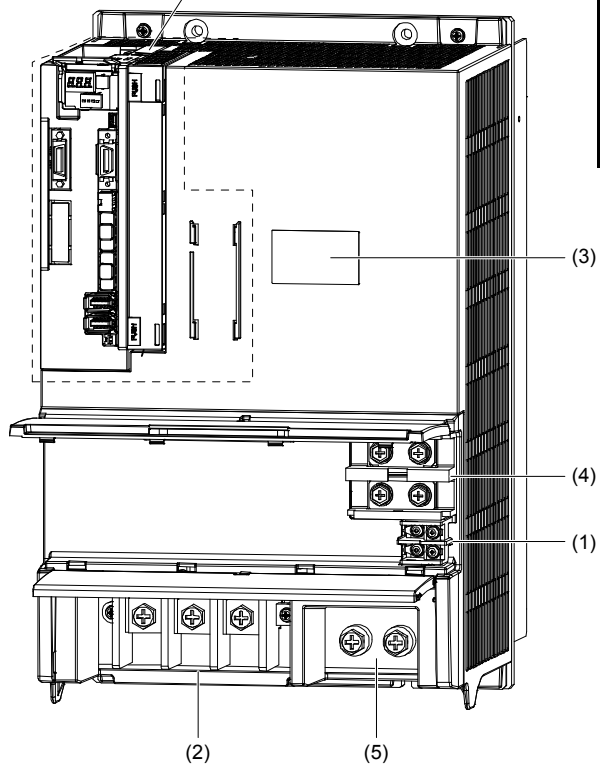

No.	Name/Application	Detailed explanation
(1)	Control circuit terminal L11/L21 (TE3) Connect to the control circuit power supply.	Section 5.2.1
(2)	Servo motor power output terminal (TE1) Connect the servo motor.	
(3)	Rating plate	Section 1.2
(4)	L+/L- terminal (TE2-1) Connect with the L+ and L- terminals of the converter unit or another drive unit by bus bars.	Section 5.2.1
(5)	Protective earth (PE) terminal	Section 5.2.1

5. MR-J4-DU_(-RJ) DRIVE UNIT

(c) MR-J4-DU30KB4(-RJ)/MR-J4-DU37KB4(-RJ)

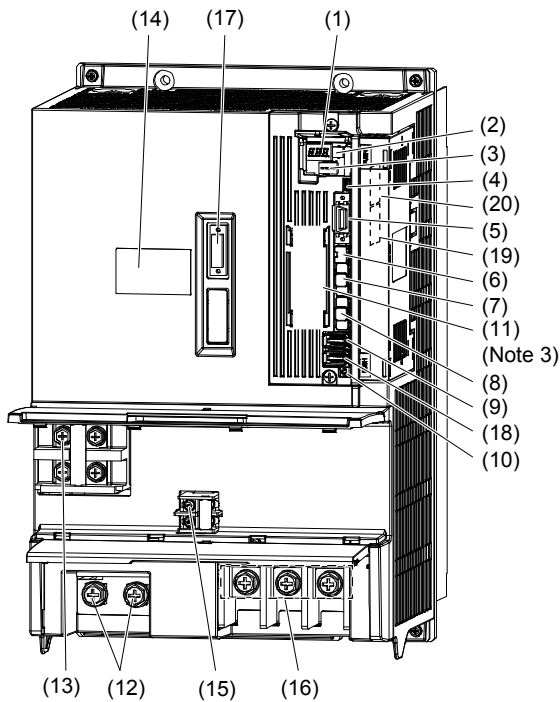

No.	Name/Application	Detailed explanation
(1)	Display The 3-digit, 7-segment LED display shows the drive unit status and the alarm number.	MR-J4-_B_ Section 4.3
(2)	Axis selection rotary switch (SW1) Used to set the axis No. of the drive unit.	
(3)	Control axis setting switch (SW2) The test operation switch, the disabling control axis switch, and the auxiliary axis number setting switch are available.	
(4)	USB communication connector (CN5) Used to connect the personal computer.	MR-J4-_B_ Section 11.7
(5)	I/O signal connector (CN3) Used to connect digital I/O signals.	MR-J4-_B_ Section 3.2 Section 3.4
(6)	STO input signal connector (CN8) Used to connect the MR-J3-D05 safety logic unit and external safety relay.	MR-J4-_B_ Chapter 13 App. 5
(7)	SSCNET III cable connector (CN1A) Used to connect the servo system controller or the previous axis servo amplifier (drive unit).	MR-J4-_B_ Section 3.2 Section 3.4
(8)	SSCNET III cable connector (CN1B) Used to connect the next axis servo amplifier (drive unit). For the final axis, put a cap.	
(9) (Note 2)	Encoder connector (CN2) Used to connect the servo motor encoder or external encoder.	MR-J4-_B_ Section 3.4 "Servo Motor Instruction Manual (Vol. 3)" Section 1.1
(10)	Battery connector (CN4) Used to connect the battery for absolute position data backup.	MR-J4-_B_ Chapter 12
(11)	Battery holder Used to house the battery for absolute position data backup.	MR-J4-_B_ Section 12.4
(12)	Protective earth (PE) terminal Grounding terminal	Section 5.2.1
(13)	L+/L- terminal (TE2-1) Connect with the L+ and L- terminals of the converter unit or another drive unit by bus bars.	
(14)	Rating plate	Section 1.2
(15)	Control circuit terminal L11/L21 (TE3) Used to connect the control circuit power supply.	Section 5.2.1
(16)	Servo motor power output terminal (TE1) Used to connect the servo motor.	
(17)	Protection coordination connector (CN40A) For the drive unit adjacent to the converter unit, connect with the CN4 of the power regeneration converter unit or the CN40 of the resistance regeneration converter unit.	
(18) (Note 1)	External encoder connector (CN2L) (Note 2) Used to connect the external encoder.	Section 5.2.2 "Linear Encoder Instruction Manual" Section 1.1
(19)	Optional unit connector (CN7) This connector is attached on the MR-J4-DU_B_-RJ drive unit. Connect an optional unit. The MR-J4-DU_B_ drive unit does not have this connector.	
(20)	Optional unit connector (CN9) This connector is attached on the MR-J4-DU_B_-RJ drive unit. Connect an optional unit. The MR-J4-DU_B_ drive unit does not have this connector.	

- Note 1. This is for the MR-J4-DU_B-RJ drive unit. The MR-J4-DU_B drive unit does not have the CN2L connector.
- Note 2. "External encoder" is a term for the load-side encoder used in the fully closed loop system and the scale measurement encoder used with the scale measurement function in this manual.
- Note 3. Lines for slots around the battery holder are omitted from the illustration.

5. MR-J4-DU_(-RJ) DRIVE UNIT

(d) MR-J4-DU45KB4(-RJ)/MR-J4-DU55KB4(-RJ)

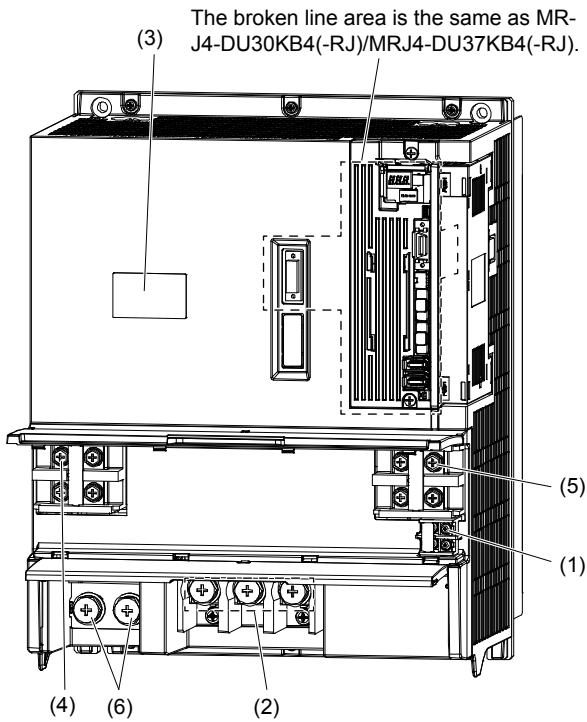

No.	Name/Application	Detailed explanation
(1)	Control circuit terminal L11/L21 (TE3) Used to connect the control circuit power supply.	Section 5.2.1
(2)	Servo motor power output terminal (TE1) Used to connect the servo motor.	
(3)	Rating plate	Section 1.2
(4)	L+/L- terminal (TE2-1) Connect with the L+ and L- terminals of the converter unit or another drive unit by bus bars.	Section 5.2.1
(5)	Manufacturer setting terminal (TE2-2) This is for manufacturer setting. Leave this open.	
(6)	Protective earth (PE) terminal Grounding terminal	Section 5.2.1

5. MR-J4-DU_(-RJ) DRIVE UNIT

5.1.2 MR-J4-DU_A_(-RJ)

"MR-J4- _A_" means "MR-J4- _A_(-RJ) Servo Amplifier Instruction Manual".

5. MR-J4-DU_(-RJ) DRIVE UNIT

(1) 200 V class

(a) MR-J4-DU30KA(-RJ)/MR-J4-DU37KA(-RJ)

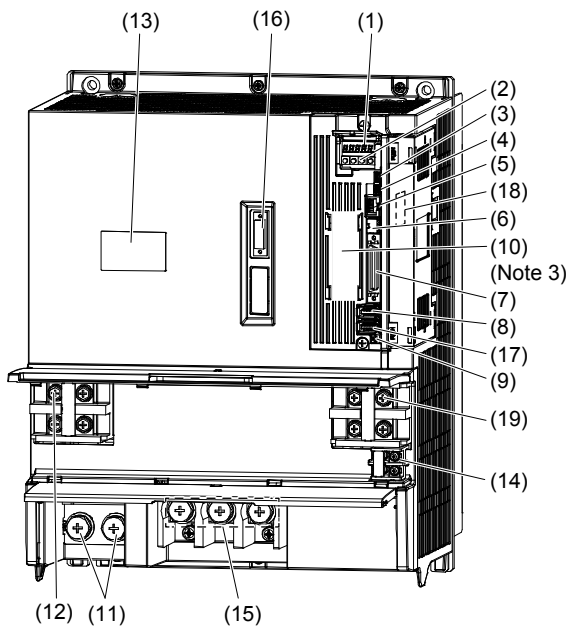

No.	Name/Application	Detailed explanation
(1)	Display The 5-digit, 7-segment LED display shows the drive unit status and the alarm number.	MR-J4-_A_ Section 4.5
(2)	Operation section Used to perform status display, diagnostic, alarm, and parameter setting operations. <p>MODE UP DOWN SET</p> <p>Used to set data. Push this button together with the "MODE" button for 3 s or more to switch to the one-touch tuning mode.</p> <p>Used to change the display or data in each mode.</p> <p>Used to change the mode. Push this button together with the "SET" button for 3 s or more to switch to the one-touch tuning mode.</p>	MR-J4-_A_ Section 4.5
(3)	USB communication connector (CN5) Used to connect the personal computer.	MR-J4-_A_ Section 11.7
(4)	Analog monitor connector (CN6) Used to output the analog monitor.	MR-J4-_A_ Section 3.2
(5)	RS-422/RS-485 communication connector (CN3) Used to connect the personal computer, etc.	MR-J4-_A_ Chapter 14
(6)	STO input signal connector (CN8) Used to connect the MR-J3-D05 safety logic unit and external safety relay.	MR-J4-_A_ Chapter 13 App. 5
(7)	I/O signal connector (CN1) Used to connect digital I/O signals.	MR-J4-_A_ Section 3.2 Section 3.4
(8) (Note 2)	Encoder connector (CN2) Used to connect the servo motor encoder or external encoder.	MR-J4-_A_ Section 3.4 "Servo Motor Instruction Manual (Vol. 3)" Section 1.1
(9)	Battery connector (CN4) Used to connect the battery for absolute position data backup.	MR-J4-_A_ Chapter 12
(10)	Battery holder Used to house the battery for absolute position data backup.	MR-J4-_A_ Section 12.2
(11)	Protective earth (PE) terminal Grounding terminal	Section 5.2.1
(12)	L+/L- terminal (TE2-1) Used to connect the L+ and L- terminals of the resistance regeneration converter unit using the bus bars.	
(13)	Rating plate	Section 1.2
(14)	Control circuit terminal L11/L21 (TE3) Used to connect the control circuit power supply.	Section 5.2.1
(15)	Servo motor power output terminal (TE1) Used to connect the servo motor.	
(16)	Protection coordination connector (CN40A) Used to connect CN40 of the resistance regeneration converter unit.	
(17) (Note 1)	External encoder connector (CN2L) (Note 2) Used to connect the external encoder.	Section 5.2.2 "Linear Encoder Instruction Manual" Section 1.1
(18)	Optional unit connector (CN7) This connector is attached on the MR-J4-DU _A_ -RJ drive unit. Connect an optional unit. The MR-J4-DU _A_ drive unit does not have this connector.	
(19)	Optional unit connector (CN9) This connector is attached on the MR-J4-DU _A_ -RJ drive unit. Connect an optional unit. The MR-J4-DU _A_ drive unit does not have this connector.	
(20)	Manufacturer setting terminal (TE2-2) This is for manufacturer setting. Leave this open.	

5. MR-J4-DU_(-RJ) DRIVE UNIT

- Note
1. This is for the MR-J4-DU_A_-RJ drive unit. The MR-J4-DU_A_ drive unit does not have the CN2L connector.
 2. "External encoder" is a term for the load-side encoder used in the fully closed loop system and the scale measurement encoder used with the scale measurement function in this manual.
 3. Lines for slots around the battery holder are omitted from the illustration.

5. MR-J4-DU_(-RJ) DRIVE UNIT

(2) 400 V class

(a) MR-J4-DU30KA4(-RJ)/MR-J4-DU37KA4(-RJ)

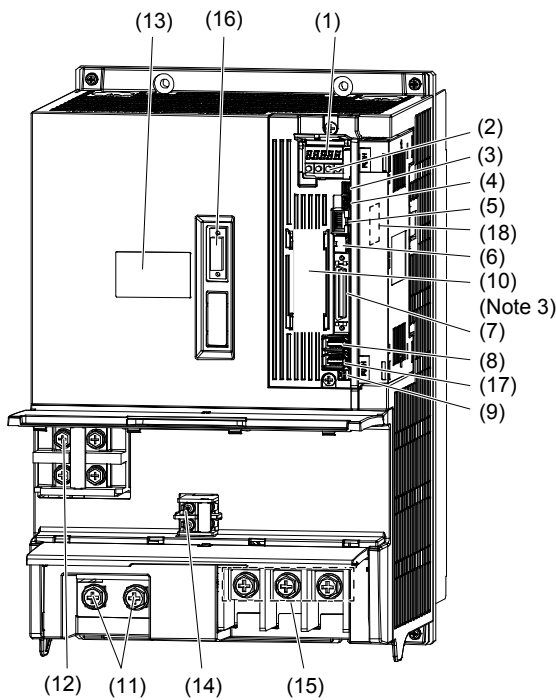

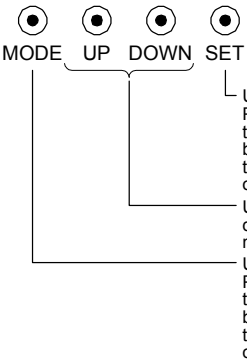
No.	Name/Application	Detailed explanation
(1)	Display The 5-digit, 7-segment LED display shows the drive unit status and the alarm number.	MR-J4-_A_ Section 4.5
(2)	Operation section Used to perform status display, diagnostic, alarm, and parameter setting operations.  <p>MODE UP DOWN SET</p> <p>Used to set data. Push this button together with the "MODE" button for 3 s or more to switch to the one-touch tuning mode.</p> <p>Used to change the display or data in each mode.</p> <p>Used to change the mode. Push this button together with the "SET" button for 3 s or more to switch to the one-touch tuning mode.</p>	MR-J4-_A_ Section 4.5
(3)	USB communication connector (CN5) Used to connect the personal computer.	MR-J4-_A_ Section 11.7
(4)	Analog monitor connector (CN6) Used to output the analog monitor.	MR-J4-_A_ Section 3.2
(5)	RS-422/RS-485 communication connector (CN3) Used to connect the personal computer, etc.	MR-J4-_A_ Chapter 14
(6)	STO input signal connector (CN8) Used to connect the MR-J3-D05 safety logic unit and external safety relay.	MR-J4-_A_ Chapter 13 App. 5
(7)	I/O signal connector (CN1) Used to connect digital I/O signals.	MR-J4-_A_ Section 3.2 Section 3.4
(8) (Note 2)	Encoder connector (CN2) Used to connect the servo motor encoder or external encoder.	MR-J4-_A_ Section 3.4 "Servo Motor Instruction Manual (Vol. 3)" Section 1.1
(9)	Battery connector (CN4) Used to connect the battery for absolute position data backup.	MR-J4-_A_ Chapter 12
(10)	Battery holder Used to house the battery for absolute position data backup.	MR-J4-_A_ Section 12.2
(11)	Protective earth (PE) terminal Grounding terminal	Section 5.2.1
(12)	L+/L- terminal (TE2-1) Used to connect the L+ and L- terminals of the resistance regeneration converter unit using the bus bars.	
(13)	Rating plate	Section 1.2
(14)	Control circuit terminal L11/L21 (TE3) Used to connect the control circuit power supply.	Section 5.2.1
(15)	Servo motor power output terminal (TE1) Used to connect the servo motor.	
(16)	Protection coordination connector (CN40A) Used to connect CN40 of the resistance regeneration converter unit.	
(17) (Note 1)	External encoder connector (CN2L) (Note 2) Used to connect the external encoder.	Section 5.2.2 "Linear Encoder Instruction Manual" Section 1.1
(18)	Optional unit connector (CN7) This connector is attached on the MR-J4-DU_A_-RJ drive unit. Connect an optional unit. The MR-J4-DU_A_ drive unit does not have this connector.	
(19)	Optional unit connector (CN9) This connector is attached on the MR-J4-DU_A_-RJ drive unit. Connect an optional unit. The MR-J4-DU_A_ drive unit does not have this connector.	

5. MR-J4-DU_(-RJ) DRIVE UNIT

- Note
1. This is for the MR-J4-DU_A_-RJ drive unit. The MR-J4-DU_A_ drive unit does not have the CN2L connector.
 2. "External encoder" is a term for the load-side encoder used in the fully closed loop system and the scale measurement encoder used with the scale measurement function in this manual.
 3. Lines for slots around the battery holder are omitted from the illustration.

(b) MR-J4-DU45KA4(-RJ)/MR-J4-DU55KA4(-RJ)

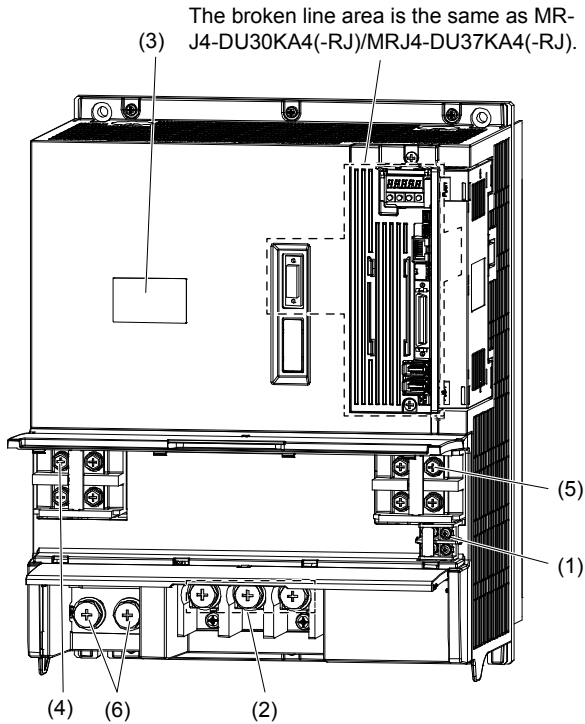

No.	Name/Application	Detailed explanation
(1)	Control circuit terminal L1/L21 (TE3) Used to connect the control circuit power supply.	Section 5.2.1
(2)	Servo motor power output terminal (TE1) Used to connect the servo motor.	
(3)	Rating plate	Section 1.2
(4)	L+/L- terminal (TE2-1) Used to connect the L+ and L- terminals of the resistance regeneration converter unit using the bus bars.	Section 5.2.1
(5)	Manufacturer setting terminal (TE2-2) This is for manufacturer setting. Leave this open.	
(6)	Protective earth (PE) terminal Grounding terminal	Section 5.2.1

5. MR-J4-DU_(-RJ) DRIVE UNIT

5.2 Signals and wiring

⚠ WARNING

- A person who is involved in wiring should be fully competent to do the work.
- Before wiring, turn off the power and wait for 20 minutes or more until the charge lamp turns off. Then, confirm that the voltage between L+ and L- is safe with a voltage tester or others. Otherwise, an electric shock may occur. In addition, always confirm that the charge lamp is off from the front of the converter unit.
- Ground the converter unit, the drive unit and the servo motor securely.
- Do not attempt to wire the converter unit, the drive unit, and the servo motor until they have been installed. Otherwise, it may cause an electric shock.
- The cables should not be damaged, stressed, loaded, or pinched. Otherwise, it may cause an electric shock.
- To avoid an electric shock, insulate the connections of the power supply terminals.

⚠ CAUTION

- Wire the equipment correctly and securely. Otherwise, the servo motor may operate unexpectedly, resulting in injury.
- Connect cables to the correct terminals. Otherwise, a burst, damage, etc. may occur.
- Ensure that polarity (+/-) is correct. Otherwise, a burst, damage, etc. may occur.
- The surge absorbing diode installed to the DC relay for control output should be fitted in the specified direction. Otherwise, the emergency stop and other protective circuits may not operate.

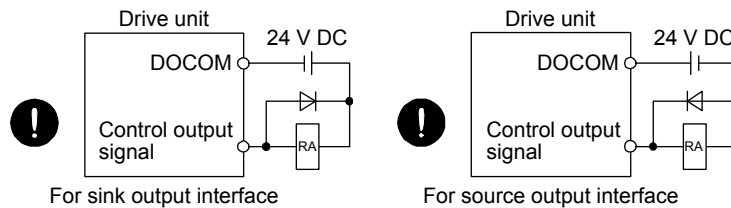

- Use a noise filter, etc. to minimize the influence of electromagnetic interference. Electromagnetic interference may be given to the electronic equipment used near the converter unit and the drive unit.
- Do not install a power capacitor, surge killer or radio noise filter (optional FR-BIF(-H)) with the power line of the servo motor.
- When using the regenerative resistor, switch power off with the alarm signal. Otherwise, a transistor fault or the like may overheat the regenerative resistor, causing a fire.
- Do not modify the equipment.

5. MR-J4-DU_(-RJ) DRIVE UNIT

CAUTION !

- Connect the drive unit power outputs (U/V/W) to the servo motor power inputs (U/V/W) directly. Do not let a magnetic contactor, etc. intervene. Otherwise, it may cause a malfunction.

- Do not connect the servo motor of a wrong axis to U, V, W, or CN2 of the drive unit. Otherwise, a malfunction may occur.
- Before wiring, switch operation, etc., eliminate static electricity. Otherwise, it may cause a malfunction.

The following items are the same as those of MR-J4-_-(-RJ). For details of the items, refer to each chapter/section indicated in the detailed explanation field. "MR-J4-_B_" means "MR-J4-_B_(-RJ) Servo Amplifier Instruction Manual". "MR-J4-_A_" means "MR-J4-_A_(-RJ) Servo Amplifier Instruction Manual".

Model	Item	Detailed explanation
MR-J4-DU_B_(-RJ)	I/O signal connection example	MR-J4-_B_ section 3.2
	Forced stop deceleration function	MR-J4-_B_ section 3.6
	SSCNET III cable connection	MR-J4-_B_ section 3.9
MR-J4-DU_A_(-RJ)	I/O signal connection example	MR-J4-_A_ section 3.2
	Forced stop deceleration function	MR-J4-_A_ section 3.7

5.2.1 Signal explanations

POINT

- For the layout of the terminal block, refer to chapter 7 DIMENSIONS.

Connection target (application)	Symbol	(Note 1) Terminal block	Description		
			MR-J4-DU900B(-RJ) MR-J4-DU11KB(-RJ) MR-J4-DU15KB(-RJ) MR-J4-DU22KB(-RJ) MR-J4-DU30KB(-RJ) MR-J4-DU37KB(-RJ) MR-J4-DU45KB(-RJ) MR-J4-DU55KB(-RJ) MR-J4-DU30KA(-RJ) MR-J4-DU37KA(-RJ) MR-J4-DU45KA(-RJ) MR-J4-DU55KA(-RJ)		
Control circuit power supply	L11/L21	TE3	Supply 1-phase 200 V AC to 240 V AC, 50 Hz/60 Hz power to L11 and L21.	Supply 1-phase 380 V AC to 480 V AC, 50 Hz/60 Hz power to L11 and L21.	
Converter unit	L+/L-	TE2-1 (TE2) (Note 2)	Connect the L+ and L- of the converter unit to this terminal. Use the bus bars to connect.		
Servo motor power input	U/V/W	TE1	Connect the drive unit power outputs (U/V/W) to the servo motor power inputs (U/V/W) directly. Do not let a magnetic contactor, etc. intervene. Otherwise, it may cause a malfunction.		
Protective earth (PE)	⊕	PE	Connect the grounding terminal of the servo motor and the protective earth (PE) of the cabinet to this terminal.		

Note 1. The permissible tension applied to any of the terminal blocks TE1, TE2-1 (TE2) is 350 N.

Note 2. Explanations in parentheses are for MR-J4-DU30K_4(-RJ) and MR-J4-DU7K_4(-RJ).

5. MR-J4-DU_(-RJ) DRIVE UNIT

5.2.2 Connectors and pin assignment

POINT
<p>● The pin assignment of the connectors is as viewed from the cable connector wiring section.</p>

(1) MR-J4-DU_B_(-RJ)

The following shows the front view of MR-J4-DU30KB4-RJ and MR-J4-DU37KB4-RJ drive units. For other views of drive units, connector arrangements, and details, refer to "MR-J4-_B_(-RJ) Servo Amplifier Instruction Manual".

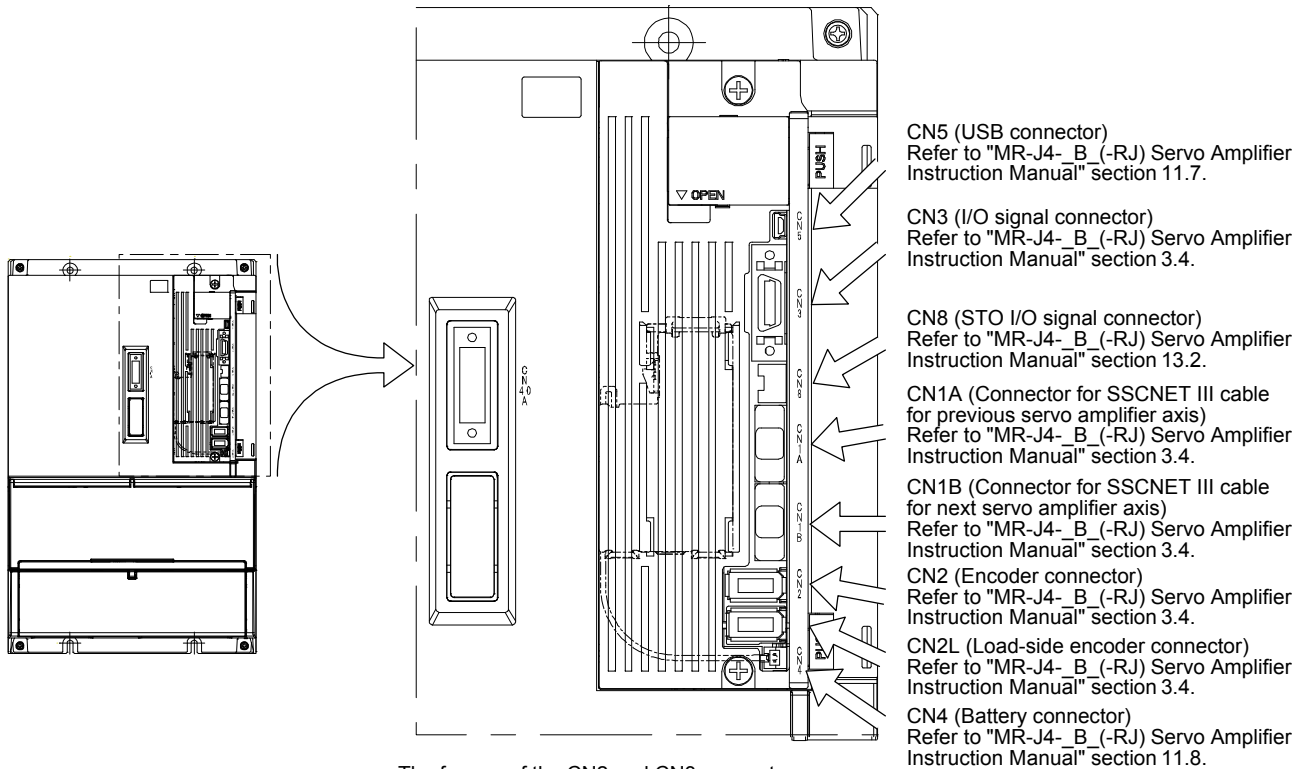

The frames of the CN2 and CN3 connectors are connected to the protective earth terminal in the drive unit.

5. MR-J4-DU_(-RJ) DRIVE UNIT

(2) MR-J4-DU_A_(-RJ)

The following shows the front view of MR-J4-DU30KA4-RJ and MR-J4-DU37KA4-RJ drive units. For other views of drive units, connector arrangements, and details, refer to "MR-J4-_A_(-RJ) Servo Amplifier Instruction Manual".

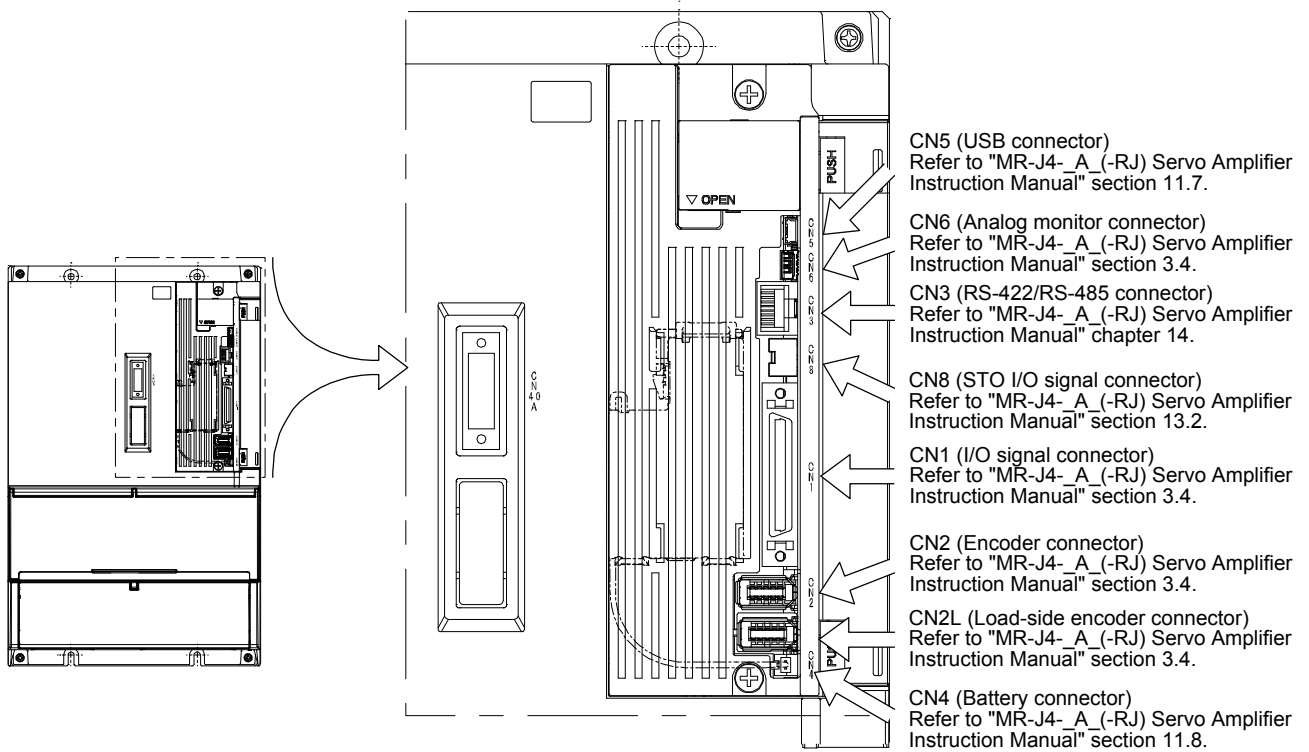

The frames of the CN2 and CN3 connectors are connected to the protective earth terminal in the drive unit.

5. MR-J4-DU_(-RJ) DRIVE UNIT

5.3 Parameter

CAUTION

- Never make a drastic adjustment or change to the parameter values as doing so will make the operation unstable.
- Do not change the parameter settings as described below. Doing so may cause an unexpected condition, such as failing to start up the drive unit.
 - Changing the values of the parameters for manufacturer setting
 - Setting a value out of the range
 - Changing the fixed values in the digits of a parameter

5.3.1 MR-J4-DU_B_(-RJ)

CAUTION

- When you write parameters with the controller, make sure that the control axis No. of the drive unit is set correctly. Otherwise, the parameter settings of another axis may be written, possibly causing the drive unit to be an unexpected condition.

POINT

- When you connect the amplifier to a servo system controller, servo parameter values of the servo system controller will be written to each parameter.
- Setting may not be made to some parameters and their ranges depending on the servo system controller model, drive unit software version, and MR Configurator2 software version. For details, refer to the servo system controller user's manual.
- The parameter whose symbol is preceded by * is enabled with the following conditions:
 - *: After setting the parameter, cycle the power or reset the controller.
 - ** : After setting the parameter, cycle the power.
- Set a value to each "x" in the "Setting digit" columns.

The following shows parameter settings exclusively for the driver unit. Other parameters are the same as those of MR-J4-_B_(-RJ). Refer to chapter 5 of "MR-J4-_B_(-RJ) Servo Amplifier Instruction Manual".

5. MR-J4-DU_(-RJ) DRIVE UNIT

No.	Symbol	Name and function	Initial value [unit]	Setting range												
PA02	**REG	<p>Regenerative option Select a regenerative option. For the drive unit, select the regenerative option with the converter unit. Selecting other than "_ _ 0 0" or "_ _ 0 1" will trigger [AL. 37 Parameter error].</p> <table border="1"> <thead> <tr> <th>Setting digit</th> <th>Explanation</th> <th>Initial value</th> </tr> </thead> <tbody> <tr> <td>_ _ x x</td> <td> <p>Regenerative option selection 00: Regenerative option is not used, or when you use a regenerative option, set the regenerative option with the converter unit. When using the drive unit with the resistance regeneration converter unit, set this value regardless of whether or not the regenerative option and brake unit are used.)</p> </td> <td>00h</td> </tr> <tr> <td>_ x _ _</td> <td> <p>Converter unit selection 0: MR-CR_ 7: MR-CV_ Setting a value other than "0" or "7" will trigger [AL. 37].</p> </td> <td>0h</td> </tr> <tr> <td>x _ _ _</td> <td> <p>Enable or disable the protection coordination mode. 0: Protection coordination mode enabled 4: Protection coordination mode disabled (stand-alone drive) Set "4" for the drive unit which is not connected to the MR-CV_ with the protection coordination cable. To disable the protection coordination mode, set "Protection coordination mode function between converter and drive unit selection" of [Pr. PF03] to "Enabled (_ 1 _)", and then this parameter to "Protection coordination mode disabled (4 _ _)".</p> </td> <td>0h</td> </tr> </tbody> </table>	Setting digit	Explanation	Initial value	_ _ x x	<p>Regenerative option selection 00: Regenerative option is not used, or when you use a regenerative option, set the regenerative option with the converter unit. When using the drive unit with the resistance regeneration converter unit, set this value regardless of whether or not the regenerative option and brake unit are used.)</p>	00h	_ x _ _	<p>Converter unit selection 0: MR-CR_ 7: MR-CV_ Setting a value other than "0" or "7" will trigger [AL. 37].</p>	0h	x _ _ _	<p>Enable or disable the protection coordination mode. 0: Protection coordination mode enabled 4: Protection coordination mode disabled (stand-alone drive) Set "4" for the drive unit which is not connected to the MR-CV_ with the protection coordination cable. To disable the protection coordination mode, set "Protection coordination mode function between converter and drive unit selection" of [Pr. PF03] to "Enabled (_ 1 _)", and then this parameter to "Protection coordination mode disabled (4 _ _)".</p>	0h	Refer to the "Name and function" column.	
Setting digit	Explanation	Initial value														
_ _ x x	<p>Regenerative option selection 00: Regenerative option is not used, or when you use a regenerative option, set the regenerative option with the converter unit. When using the drive unit with the resistance regeneration converter unit, set this value regardless of whether or not the regenerative option and brake unit are used.)</p>	00h														
_ x _ _	<p>Converter unit selection 0: MR-CR_ 7: MR-CV_ Setting a value other than "0" or "7" will trigger [AL. 37].</p>	0h														
x _ _ _	<p>Enable or disable the protection coordination mode. 0: Protection coordination mode enabled 4: Protection coordination mode disabled (stand-alone drive) Set "4" for the drive unit which is not connected to the MR-CV_ with the protection coordination cable. To disable the protection coordination mode, set "Protection coordination mode function between converter and drive unit selection" of [Pr. PF03] to "Enabled (_ 1 _)", and then this parameter to "Protection coordination mode disabled (4 _ _)".</p>	0h														

5. MR-J4-DU_(-RJ) DRIVE UNIT

No.	Symbol	Name and function	Initial value [unit]	Setting range															
PA20	*TDS	<p>Tough drive setting</p> <p>Alarms may not be avoided with the tough drive function depending on the situations of the power supply and load fluctuation.</p> <p>You can assign MTTR (During tough drive) to pins CN3-9, CN3-13, and CN3-15 with [Pr. PD07] to [Pr. PD09].</p> <table border="1"> <thead> <tr> <th>Setting digit</th> <th>Explanation</th> <th>Initial value</th> </tr> </thead> <tbody> <tr> <td>___x</td> <td>For manufacturer setting</td> <td>0h</td> </tr> <tr> <td>__x_</td> <td> <p>Vibration tough drive selection</p> <p>0: Disabled</p> <p>1: Enabled</p> <p>Selecting "1" enables to suppress vibrations by automatically changing setting values of [Pr. PB13 Machine resonance suppression filter 1] and [Pr. PB15 Machine resonance suppression filter 2] in case that the vibration exceeds the value of the oscillation level set in [Pr. PF23].</p> <p>For details, refer to section 7.3 of "MR-J4-_B_(-RJ) Servo Amplifier Instruction Manual".</p> </td> <td>0h</td> </tr> <tr> <td>_x__</td> <td> <p>SEMI-F47 function selection</p> <p>The [Pr. PA20 SEMI-F47 function selection] and [Pr. PF25 SEMI-F47 function - Instantaneous power failure detection time] settings of the drive unit must be the same as [Pr. PA17 SEMI-F47 function selection] and [Pr. PA18 SEMI-F47 function - Instantaneous power failure detection time] settings of the converter unit.</p> <p>0: Disabled</p> <p>1: Enabled</p> <p>Selecting "1" enables to avoid triggering [AL. 10 Undervoltage] using the electrical energy charged in the capacitor in case that an instantaneous power failure occurs during operation. In [Pr. PF25 SEMI-F47 function - Instantaneous power failure detection time], set the time until the occurrence of [AL. 10.1 Voltage drop in the control circuit power].</p> </td> <td>0h</td> </tr> <tr> <td>x___</td> <td>For manufacturer setting</td> <td>0h</td> </tr> </tbody> </table>	Setting digit	Explanation	Initial value	___x	For manufacturer setting	0h	__x_	<p>Vibration tough drive selection</p> <p>0: Disabled</p> <p>1: Enabled</p> <p>Selecting "1" enables to suppress vibrations by automatically changing setting values of [Pr. PB13 Machine resonance suppression filter 1] and [Pr. PB15 Machine resonance suppression filter 2] in case that the vibration exceeds the value of the oscillation level set in [Pr. PF23].</p> <p>For details, refer to section 7.3 of "MR-J4-_B_(-RJ) Servo Amplifier Instruction Manual".</p>	0h	_x__	<p>SEMI-F47 function selection</p> <p>The [Pr. PA20 SEMI-F47 function selection] and [Pr. PF25 SEMI-F47 function - Instantaneous power failure detection time] settings of the drive unit must be the same as [Pr. PA17 SEMI-F47 function selection] and [Pr. PA18 SEMI-F47 function - Instantaneous power failure detection time] settings of the converter unit.</p> <p>0: Disabled</p> <p>1: Enabled</p> <p>Selecting "1" enables to avoid triggering [AL. 10 Undervoltage] using the electrical energy charged in the capacitor in case that an instantaneous power failure occurs during operation. In [Pr. PF25 SEMI-F47 function - Instantaneous power failure detection time], set the time until the occurrence of [AL. 10.1 Voltage drop in the control circuit power].</p>	0h	x___	For manufacturer setting	0h	Refer to the "Name and function" column.	
Setting digit	Explanation	Initial value																	
___x	For manufacturer setting	0h																	
__x_	<p>Vibration tough drive selection</p> <p>0: Disabled</p> <p>1: Enabled</p> <p>Selecting "1" enables to suppress vibrations by automatically changing setting values of [Pr. PB13 Machine resonance suppression filter 1] and [Pr. PB15 Machine resonance suppression filter 2] in case that the vibration exceeds the value of the oscillation level set in [Pr. PF23].</p> <p>For details, refer to section 7.3 of "MR-J4-_B_(-RJ) Servo Amplifier Instruction Manual".</p>	0h																	
_x__	<p>SEMI-F47 function selection</p> <p>The [Pr. PA20 SEMI-F47 function selection] and [Pr. PF25 SEMI-F47 function - Instantaneous power failure detection time] settings of the drive unit must be the same as [Pr. PA17 SEMI-F47 function selection] and [Pr. PA18 SEMI-F47 function - Instantaneous power failure detection time] settings of the converter unit.</p> <p>0: Disabled</p> <p>1: Enabled</p> <p>Selecting "1" enables to avoid triggering [AL. 10 Undervoltage] using the electrical energy charged in the capacitor in case that an instantaneous power failure occurs during operation. In [Pr. PF25 SEMI-F47 function - Instantaneous power failure detection time], set the time until the occurrence of [AL. 10.1 Voltage drop in the control circuit power].</p>	0h																	
x___	For manufacturer setting	0h																	

5. MR-J4-DU_(-RJ) DRIVE UNIT

No.	Symbol	Name and function	Initial value [unit]	Setting range																																
PC23	**COP7A	<p>Function selection C-7A</p> <p>This parameter setting is available with servo amplifiers with software version D0 or later. When maximum torque increase by compatible servo motors listed on the following table, select the maximally increased torque function when those drive units are connected.</p> <table border="1" data-bbox="475 459 1139 736"> <thead> <tr> <th>Drive unit</th> <th>Servo motor</th> <th>Maximum torque in percentage to rated torque</th> </tr> </thead> <tbody> <tr> <td rowspan="3">MR-J4-DU900B</td> <td>HG-SR702</td> <td>400%</td> </tr> <tr> <td>HG-JR703</td> <td>350%</td> </tr> <tr> <td>HG-JR701M</td> <td>350%</td> </tr> <tr> <td rowspan="3">MR-J4-DU900B4</td> <td>HG-SR7024</td> <td>400%</td> </tr> <tr> <td>HG-JR7034</td> <td>350%</td> </tr> <tr> <td>HG-JR701M4</td> <td>350%</td> </tr> </tbody> </table> <table border="1" data-bbox="347 768 1230 1211"> <thead> <tr> <th>Setting digit</th> <th>Explanation</th> <th>Initial value</th> </tr> </thead> <tbody> <tr> <td>___x</td> <td>For manufacturer setting</td> <td>0h</td> </tr> <tr> <td>__x_</td> <td> <p>Maximally increased torque function selection when drive unit is connected</p> <p>A servo motor's maximum torque can be increased by selecting "1" when using a servo motor which supports maximally increased torque.</p> <p>0: Disabled 1: Enabled</p> <p>When using a servo motor which does not support maximally increased torque, setting "1" will trigger [AL. 37 Parameter error].</p> </td> <td>0h</td> </tr> <tr> <td>_x__</td> <td>For manufacturer setting</td> <td>0h</td> </tr> <tr> <td>x___</td> <td>For manufacturer setting</td> <td>0h</td> </tr> </tbody> </table>	Drive unit	Servo motor	Maximum torque in percentage to rated torque	MR-J4-DU900B	HG-SR702	400%	HG-JR703	350%	HG-JR701M	350%	MR-J4-DU900B4	HG-SR7024	400%	HG-JR7034	350%	HG-JR701M4	350%	Setting digit	Explanation	Initial value	___x	For manufacturer setting	0h	__x_	<p>Maximally increased torque function selection when drive unit is connected</p> <p>A servo motor's maximum torque can be increased by selecting "1" when using a servo motor which supports maximally increased torque.</p> <p>0: Disabled 1: Enabled</p> <p>When using a servo motor which does not support maximally increased torque, setting "1" will trigger [AL. 37 Parameter error].</p>	0h	_x__	For manufacturer setting	0h	x___	For manufacturer setting	0h	Refer to the "Name and function" column.	
Drive unit	Servo motor	Maximum torque in percentage to rated torque																																		
MR-J4-DU900B	HG-SR702	400%																																		
	HG-JR703	350%																																		
	HG-JR701M	350%																																		
MR-J4-DU900B4	HG-SR7024	400%																																		
	HG-JR7034	350%																																		
	HG-JR701M4	350%																																		
Setting digit	Explanation	Initial value																																		
___x	For manufacturer setting	0h																																		
__x_	<p>Maximally increased torque function selection when drive unit is connected</p> <p>A servo motor's maximum torque can be increased by selecting "1" when using a servo motor which supports maximally increased torque.</p> <p>0: Disabled 1: Enabled</p> <p>When using a servo motor which does not support maximally increased torque, setting "1" will trigger [AL. 37 Parameter error].</p>	0h																																		
_x__	For manufacturer setting	0h																																		
x___	For manufacturer setting	0h																																		

5. MR-J4-DU_(-RJ) DRIVE UNIT

No.	Symbol	Name and function	Initial value [unit]	Setting range	
PF03	*FOP5	Function selection F-5		Refer to the Name and function column.	
		Setting digit	Explanation		Initial value
		___x	For manufacturer setting		0h
		__x_			0h
		_x__	Protection coordination mode function between converter and drive unit selection 0: Disabled 1: Enabled When "Enabled (_ 1 __)" is selected in this parameter, the setting value in "Protection coordination mode selection between converter and drive unit" of [Pr. PA02] is enabled.		0h
x___	For manufacturer setting	0h			
PF07	*FOP6	Function selection F-6		Refer to the Name and function column.	
		Setting digit	Explanation		Initial value
		___x	For manufacturer setting		0h
		__x_			0h
		_x__	Magnetic contactor shut-off selection at STO input Select whether turning the magnetic contactor off when STO is inputted ([when AL. 95 has occurred]). Selecting "_ 1 __" keeps the main circuit power supply on when STO is inputted. 0: Turns the magnetic contactor off when STO is inputted ([when AL. 95 has occurred]). 1: Keeps the magnetic contactor on when STO is inputted ([when AL. 95 has occurred]).		0h
x___	Magnetic contactor shut-off selection at forced stop input Select whether turning the magnetic contactor off when the forced stop is inputted ([when AL. E6 has occurred]). Selecting "_ 1 __" keeps the main circuit power supply on when the forced stop is inputted. 0: Turns the magnetic contactor off when the forced stop is inputted ([when AL. E6 has occurred]). 1: Keeps the magnetic contactor on when the forced stop is inputted ([when AL. E6 has occurred]). This parameter is enabled only when the power regeneration converter unit is selected ([Pr. PA02]: _ 7 __). If MR-CR_ resistance regeneration converter unit is selected ([Pr. PA02]: _ 0 __), the magnetic contactor will be kept on when the forced stop is inputted ([when AL. E6 has occurred]) regardless the setting.	0h			
PF25	CVAT	The [Pr. PA20 SEMI-F47 function selection] and [Pr. PF25 SEMI-F47 function - Instantaneous power failure detection time] settings of the drive unit must be the same as [Pr. PA17 SEMI-F47 function selection] and [Pr. PA18 SEMI-F47 function - Instantaneous power failure detection time] settings of the converter unit.		200 [ms] 30 to 200	
		SEMI-F47 function - Instantaneous power failure detection time Set the time until the occurrence of [AL. 10.1 Voltage drop in the control circuit power]. To disable the parameter setting value, select "Disabled (_ 0 __)" of "SEMI-F47 function selection" in [Pr. PA20].			

5. MR-J4-DU_(-RJ) DRIVE UNIT

5.3.2 MR-J4-DU_A_(-RJ)

POINT
<ul style="list-style-type: none"> ● To enable a parameter whose symbol is preceded by *, cycle the power after setting it. ● Set a value to each "x" in the "Setting digit" columns.

The following shows parameter settings exclusively for the driver unit. Other parameters are the same as those of MR-J4-_A_(-RJ). Refer to chapter 5 of "MR-J4-_A_(-RJ) Servo Amplifier Instruction Manual".

No./symbol/ name	Setting digit	Function	Initial value [unit]
PA02 *REG Regenerative option	__ x x	Regenerative option Select a regenerative option. For the drive unit, select the regenerative option with the converter unit. Selecting other than "__ 0 0" or "__ 0 1" will trigger [AL. 37 Parameter error]. 00: Regenerative option is not used, or when you use a regenerative option, set the regenerative option with the converter unit. When using the drive unit with the resistance regeneration converter unit, set this value regardless of whether or not the regenerative option and brake unit are used.)	00h
	_ x _ _	For manufacturer setting	0h
	x _ _ _		0h
PA20 *TDS Tough drive setting		Alarms may not be avoided with the tough drive function depending on the situations of the power supply and load fluctuation. You can assign MTTR (During tough drive) to pins CN1-22 to CN1-25, CN1-49, CN1-13, and CN1-14 with [Pr. PD23] to [Pr. PD26], [Pr. PD28], and [Pr. PD47].	
	_ _ _ x	For manufacturer setting	0h
	_ _ x _	Vibration tough drive selection 0: Disabled 1: Enabled Selecting "1" enables to suppress vibrations by automatically changing setting values of [Pr. PB13 Machine resonance suppression filter 1] and [Pr. PB15 Machine resonance suppression filter 2] in case that the vibration exceeds the value of the oscillation level set in [Pr. PF23]. To output the oscillation detection alarm as a warning, set [Pr. PF24 Vibration tough drive function selection]. For details, refer to section 7.3 of "MR-J4-_A_(-RJ) Servo Amplifier Instruction Manual".	0h
	_ x _ _	SEMI-F47 function selection The [Pr. PA20 SEMI-F47 function selection] and [Pr. PF25 SEMI-F47 function - Instantaneous power failure detection time] settings of the drive unit must be the same as [Pr. PA17 SEMI-F47 function selection] and [Pr. PA18 SEMI-F47 function - Instantaneous power failure detection time] settings of the converter unit. 0: Disabled 1: Enabled Selecting "1" enables to avoid triggering [AL. 10 Undervoltage] using the electrical energy charged in the capacitor in case that an instantaneous power failure occurs during operation. In [Pr. PF25 SEMI-F47 function - Instantaneous power failure detection time], set the time until the occurrence of [AL. 10.1 Voltage drop in the control circuit power].	0h
	x _ _ _	For manufacturer setting	0h
PF25 CVAT SEMI-F47 function - Instanta- neous power failure detection time		The [Pr. PA20 SEMI-F47 function selection] and [Pr. PF25 SEMI-F47 function - Instantaneous power failure detection time] settings of the drive unit must be the same as [Pr. PA17 SEMI-F47 function selection] and [Pr. PA18 SEMI-F47 function - Instantaneous power failure detection time] settings of the converter unit.	
		Set the time until the occurrence of [AL. 10.1 Voltage drop in the control circuit power]. To disable the parameter setting value, select "Disabled (_ 0 _ _)" of "SEMI-F47 function selection" in [Pr. PA20]. Setting range: 30 to 200	200 [ms]

5. MR-J4-DU_(-RJ) DRIVE UNIT

5.4 Characteristics

The following items are the same as those of MR-J4_(-RJ). For details of the items, refer to each chapter/section of the detailed explanation field. "MR-J4-_B_" means "MR-J4-_B_(-RJ) Servo Amplifier Instruction Manual". "MR-J4-_A_" means "MR-J4-_A_(-RJ) Servo Amplifier Instruction Manual".

Model	Item	Detailed explanation
MR-J4-DU_B_(-RJ)	Cable bending life	MR-J4-_B_ section 10.4
MR-J4-DU_A_(-RJ)	Cable bending life	MR-J4-_A_ section 10.4

5.4.1 Drive unit

An electronic thermal is built in the drive unit to protect the servo motor, drive unit and servo motor power wires from overloads.

[AL. 50 Overload 1] occurs if overload operation performed is above the electronic thermal protection curve shown in the following figure. [AL. 51 Overload 2] occurs if the maximum current is applied continuously for several seconds due to machine collision, etc. [AL. 51 Overload 2] occurs if the maximum current is applied continuously for several seconds due to machine collision, etc. Use the equipment on the left-side area of the continuous or broken line in the graph.

For the system where the unbalanced torque occurs, such as a vertical axis system, the unbalanced torque of the machine should be kept at 70% or lower of the motor's rated torque.

The drive unit has the servo motor overload protective function. (The servo motor overload current (full load current) is set on the basis of 120% rated current of the drive unit.)

5. MR-J4-DU_(-RJ) DRIVE UNIT

The following table shows combinations of each servo motor and graph of overload protection characteristics.

Rotary servo motor		Graph
HG-SR	HG-JR	
702 7024	503 703 701M 5034 7034	Characteristics A
	11K1M 903 9034 12K14 11K1M4 15K1M4 37K14 12K1 37K1 15K1M 801 15K1 20K1 25K1 30K1 22K1M 30K1M 37K1M 8014 15K14 20K14 25K14 30K14 22K1M4 30K1M4 37K1M4 45K1M4	Characteristics B
	601 6014 701M4	Characteristics A
	55K1M4	Characteristics B

5. MR-J4-DU_(-RJ) DRIVE UNIT

(1) Characteristics A

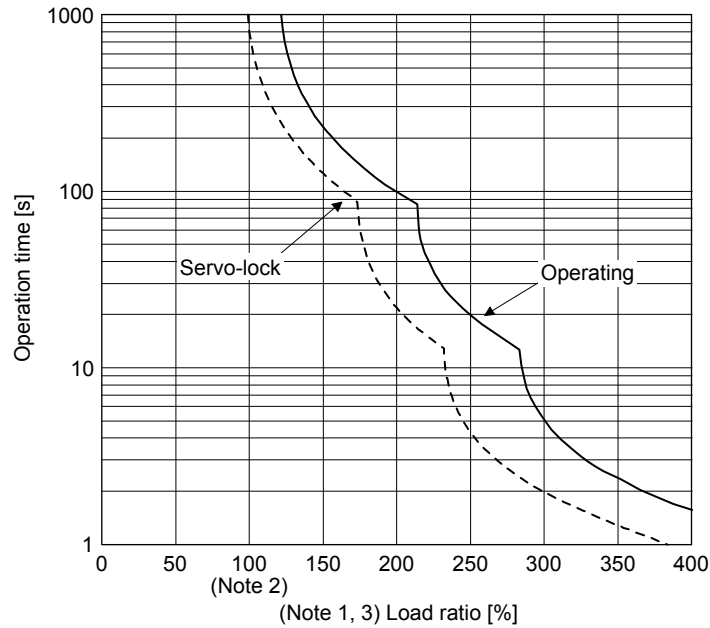

- Note 1. If operation that generates torque more than 100% of the rating is performed with an abnormally high frequency in a servo motor stop status (servo-lock status) or in a 30 r/min or less low-speed operation status, the drive unit may malfunction regardless of the electronic thermal protection.
- Note 2. Load ratio 100% indicates the rated output of the drive unit. Refer to section 1.4.3 for rated output.
- Note 3. The operation time at the load ratio of 300% to 400% applies when the maximum torque is increased to 400% of rated torque.

(2) Characteristics B

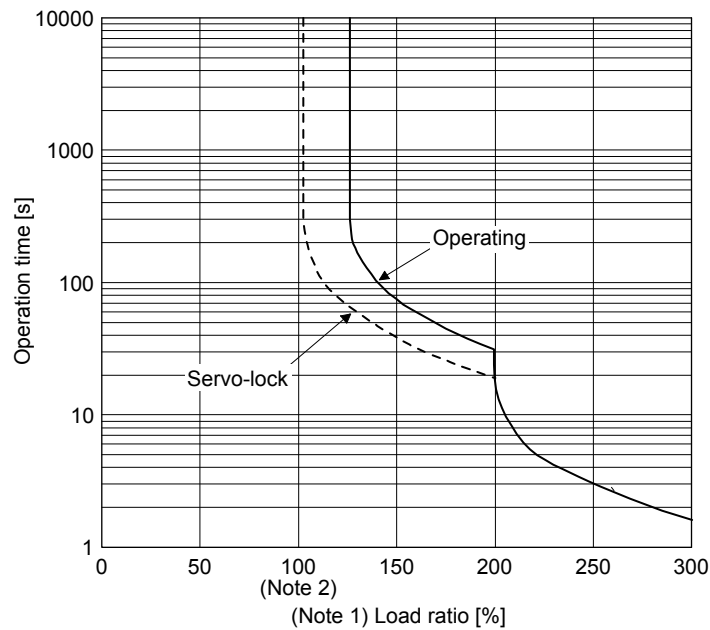

- Note 1. If operation that generates torque more than 100% of the rating is performed with an abnormally high frequency in a servo motor stop status (servo-lock status) or in a 30 r/min or less low-speed operation status, the drive unit may malfunction regardless of the electronic thermal protection.
- Note 2. Load ratio 100% indicates the rated output of the drive unit. Refer to section 1.4.3 for rated output.

5. MR-J4-DU_(-RJ) DRIVE UNIT

5.4.2 Dynamic brake characteristics

CAUTION

- The coasting distance is a theoretically calculated value which ignores the running load such as friction. The calculated value will be longer than the actual distance. If an enough braking distance is not provided, a moving part may crash into the stroke end, which is very dangerous. Install the anti-crash mechanism such as an air brake or an electric/mechanical stopper such as a shock absorber to reduce the shock of moving parts.

POINT

- Do not use dynamic brake to stop in a normal operation as it is the function to stop in emergency.
- For a machine operating at the recommended load to motor inertia ratio or less, the estimated number of usage times of the dynamic brake is 1000 times while the machine decelerates from the rated speed to a stop once in 10 minutes.
- Be sure to enable EM1 (Forced stop 1) after servo motor stops when using EM1 frequently in other than emergency.
- Servo motors for MR-J4 may have the different coasting distance from that of the previous model.

5. MR-J4-DU_(-RJ) DRIVE UNIT

(1) Calculation of coasting distance

The following figure shows the pattern in which the servo motor comes to a stop when the dynamic brake is operated.

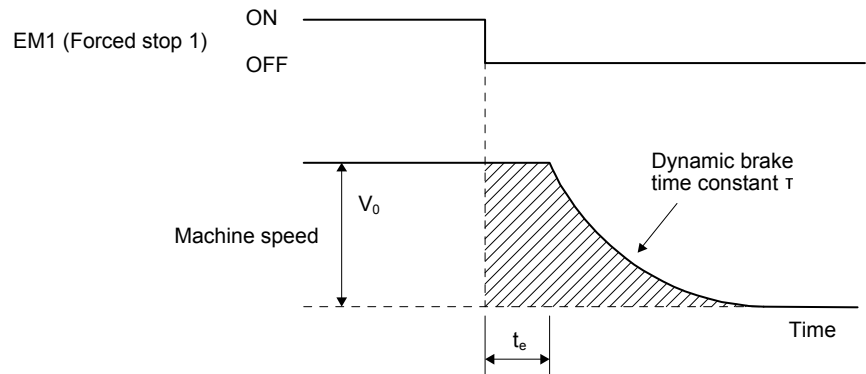

Use the following equation to calculate an approximate coasting distance to a stop.

$$L_{\max} = \frac{V_0}{60} \cdot \left\{ t_e + \tau \left(1 + \frac{J_L}{J_M} \right) \right\}$$

- L_{\max} : Maximum coasting distance [mm]
 - V_0 : Machine's fast feed speed [mm/min]
 - J_M : Moment of inertia of the servo motor [$\times 10^{-4}$ kg·m²]
 - J_L : Load moment of inertia converted into equivalent value on servo motor shaft [$\times 10^{-4}$ kg·m²]
 - τ : Dynamic brake time constant [s]
 - t_e : Delay time of control section [s]
- There is delay caused by magnetic contactor built into the external dynamic brake (about 50 ms) and delay caused by the external relay.

The dynamic brake time constant τ varies with the servo motor and machine operation speeds. (Refer to (2) in this section.)

A working part generally has a friction force. Therefore, actual coasting distance will be shorter than a maximum coasting distance calculated with the following equation.

5. MR-J4-DU_(-RJ) DRIVE UNIT

(2) Dynamic brake time constant

(a) 200 V class HG-SR2000 r/min series

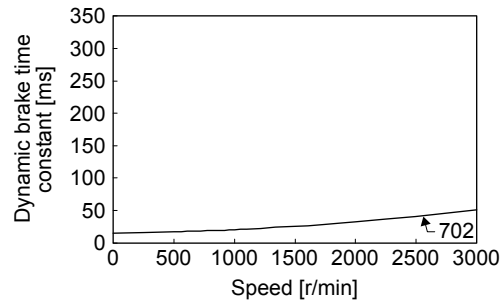

(b) 200 V class HG-JR1000 r/min series

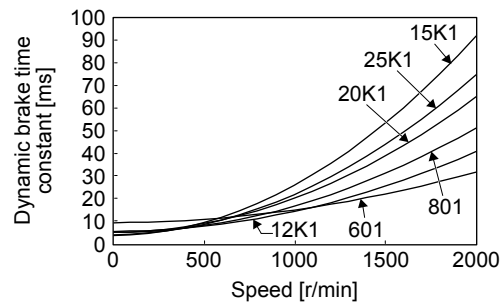

(c) 200 V class HG-JR1500 r/min series

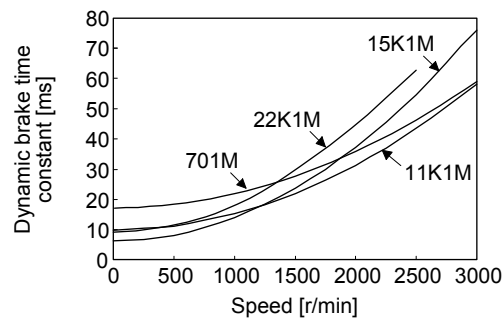

(d) 200 V class HG-JR3000 r/min series

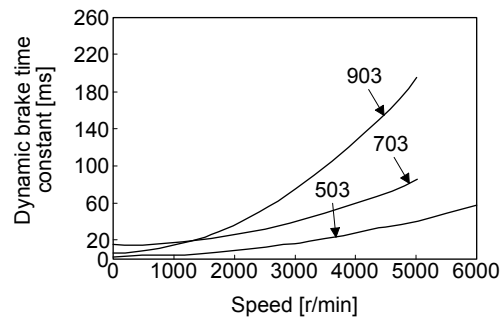

5. MR-J4-DU_(-RJ) DRIVE UNIT

(e) 200 V class HG-JR1000 r/min series

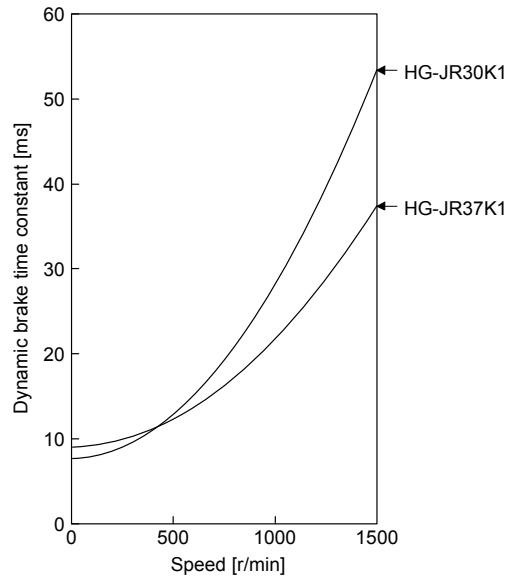

(f) 200 V class HG-JR1500 r/min series

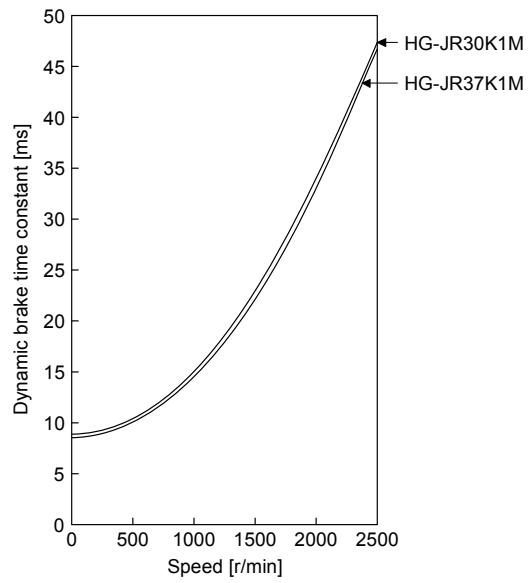

5. MR-J4-DU_(-RJ) DRIVE UNIT

(g) 400 V class HG-SR series

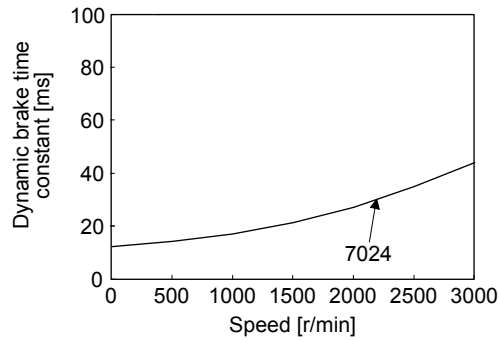

(h) 400 V class HG-JR1000 r/min series

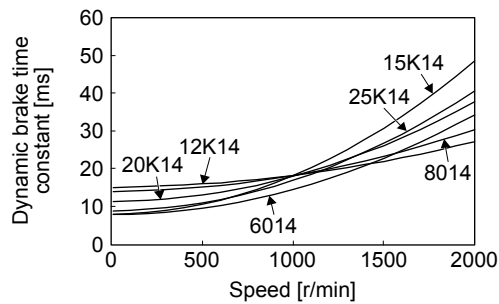

(i) 400 V class HG-JR1500 r/min series

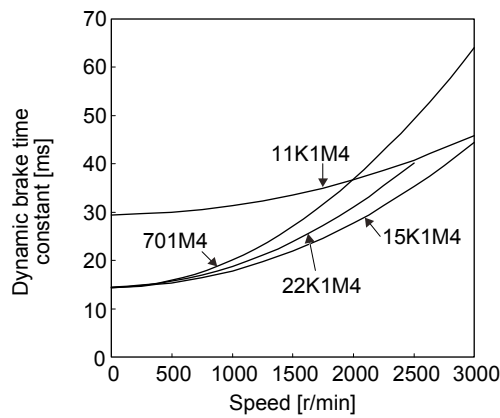

(j) 400 V class HG-JR3000 r/min series

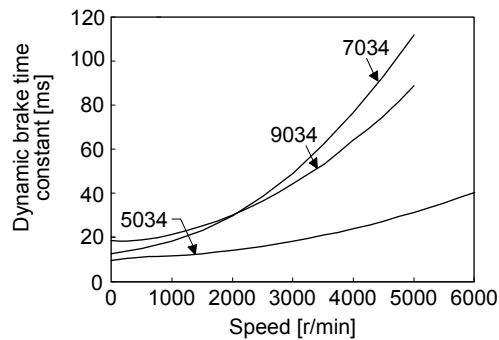

5. MR-J4-DU_(-RJ) DRIVE UNIT

(k) 400 V class HG-JR1000 r/min series

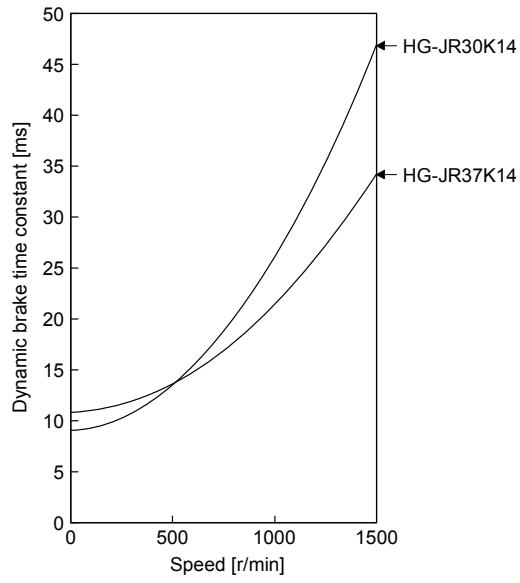

(l) 400 V class HG-JR1500 r/min series

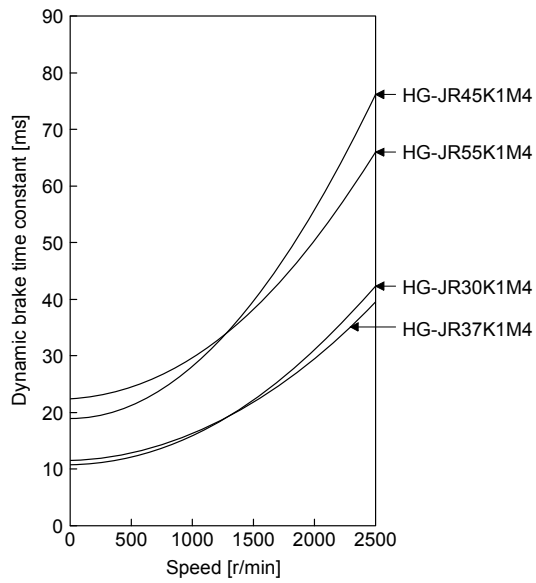

5. MR-J4-DU_(-RJ) DRIVE UNIT

(3) Permissible load to motor inertia when the dynamic brake is used

Use the dynamic brake under the load to motor inertia ratio indicated in the following table. If the ratio is higher than this value, the dynamic brake may burn. If there is a possibility that the ratio may exceed the value, contact your local sales office.

The values of the permissible load to motor inertia ratio in the table are the values at the maximum rotation speed of the servo motor. The value in the parenthesis shows the value at the rated speed.

Servo motor	Load to motor inertia ratio [multiplier]
HG-JR703	21 (30)
HG-JR601	30
HG-JR701M	14 (30)
HG-SR702	18 (30)
HG-JR903	18 (30)
HG-JR801	30
HG-JR12K1	20 (30)
HG-JR11K1M	10 (30)
HG-JR15K1	17 (30)
HG-JR15K1M	10 (30)
HG-JR20K1	26 (30)
HG-JR22K1M	20 (30)
HG-JR25K1	21 (30)
HG-JR7034	21 (30)
HG-JR6014	30
HG-JR701M4	14 (30)
HG-SR7024	18 (30)
HG-JR9034	18 (30)
HG-JR8014	30
HG-JR12K14	20 (30)
HG-JR11K1M4	10 (30)
HG-JR15K14	30 (30)
HG-JR15K1M4	10 (30)
HG-JR20K14	26 (30)
HG-JR22K1M4	20 (30)
HG-JR25K14	21 (30)
HG-JR30K1	10
HG-JR37K1	
HG-JR30K14	
HG-JR37K14	
HG-JR30K1M	
HG-JR37K1M	
HG-JR30K1M4	
HG-JR37K1M4	
HG-JR45K1M4	8 (10)
HG-JR55K1M4	7 (10)

5. MR-J4-DU_(-RJ) DRIVE UNIT

5.4.3 Inrush currents at power-on of control circuit

Since large inrush currents flow in the power supplies, always use molded-case circuit breakers and magnetic contactors. (Refer to section 8.5.)

When circuit protectors are used, it is recommended that the inertia delay type, which is not tripped by an inrush current, be used.

(1) 200 V class

The following table indicates the inrush currents (reference data) that will flow when 240 V AC is applied at the power supply capacity.

Drive unit	Inrush currents (A_{0-P})
	Control circuit power supply (L11/L21)
MR-J4-DU900B(-RJ)	23 A (attenuated to approx. 2 A in 8 ms)
MR-J4-DU11KB(-RJ)	
MR-J4-DU15KB(-RJ)	
MR-J4-DU22KB(-RJ)	
MR-J4-DU30K_(-RJ)	31 A (attenuated to approx. 2 A in 60 ms)
MR-J4-DU37K_(-RJ)	

(2) 400 V class

The following table indicates the inrush currents (reference data) that will flow when 480 V AC is applied at the power supply capacity.

Drive unit	Inrush currents (A_{0-P})
	Control circuit power supply (L11/L21)
MR-J4-DU900B4(-RJ)	15 A (attenuated to approx. 2 A in 9 ms)
MR-J4-DU11KB4(-RJ)	
MR-J4-DU15KB4(-RJ)	
MR-J4-DU22KB4(-RJ)	
MR-J4-DU30K_4(-RJ)	27 A (attenuated to approx. 2 A in 45 ms)
MR-J4-DU37K_4(-RJ)	
MR-J4-DU45K_4(-RJ)	
MR-J4-DU55K_4(-RJ)	

5. MR-J4-DU_(-RJ) DRIVE UNIT

5.5 Mounting and removing MR-D30

WARNING

- Before mounting and removing MR-D30, turn off the power and wait for 20 minutes or more until the charge lamp turns off. In addition, when confirming whether the charge lamp is off or not, always confirm it from the front of the converter unit.

CAUTION

- Do not mount and remove MR-D30 frequently. Otherwise, a contact failure may be caused in the connector.
- To protect the connectors from dusts and dirt, unpack MR-D30 only when it is ready to be attached. When storing MR-D30, be sure to cover the unit with a packing bag in which the unit had been covered prior to shipping.
- Do not use MR-D30 if its fixing hook or clips are broken. Otherwise, a contact failure may be caused in the connector.
- When mounting and removing the MR-D30, do not drop the mounting screws to the inside of the drive unit. Otherwise, the drive unit may malfunction.
- When mounting the MR-D30, be careful not to damage the control board in the drive unit by the fixing plate. Otherwise, the drive unit may malfunction.
- Be sure to use the enclosed mounting screws for fixing the MR-D30.

POINT

- The internal circuits of the drive unit and MR-D30 may be damaged by static electricity. Always take the following precautions.
 - Ground human body and work bench.
 - Do not touch the conductive areas, such as connector pins and electrical parts, directly by hand.

5. MR-J4-DU_(-RJ) DRIVE UNIT

5.5.1 MR-J4-DU900B-RJ to MR-J4-DU22KB-RJ/MR-J4-DU900B4-RJ to MR-J4-DU22KB4-RJ

(1) Mounting the MR-D30

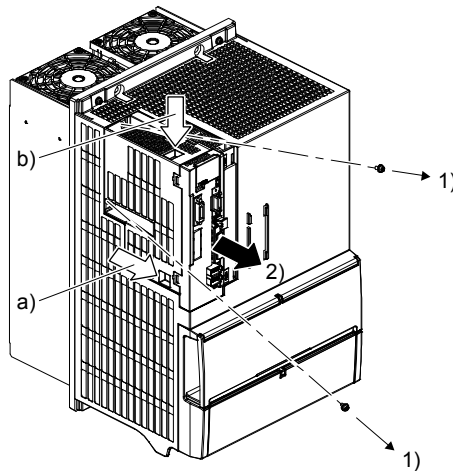

- 1) Remove the mounting screw.
- 2) Fit your fingers in a) and b) to pull the control interface off the drive unit in the arrow direction. Do not pull without removing the mounting screws.

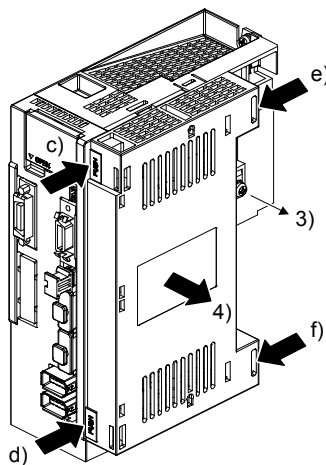

- 3) Remove the mounting screw.
- 4) While pushing the clips (c), d), e), f)), pull out the case in the arrow direction. Do not pull the case without removing the mounting screws.

5. MR-J4-DU_(-RJ) DRIVE UNIT

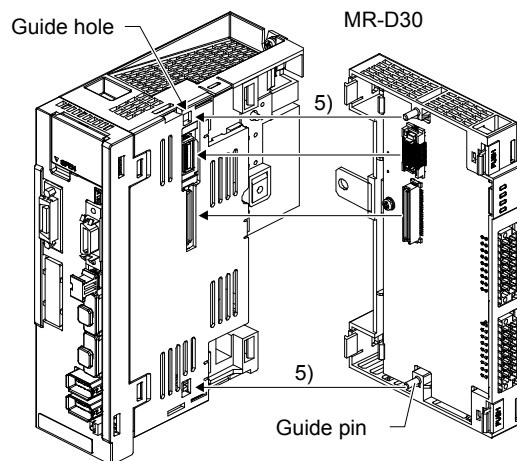

- 5) Insert the guide pins of the MR-D30 in the guide holes located on the side of the control interface.

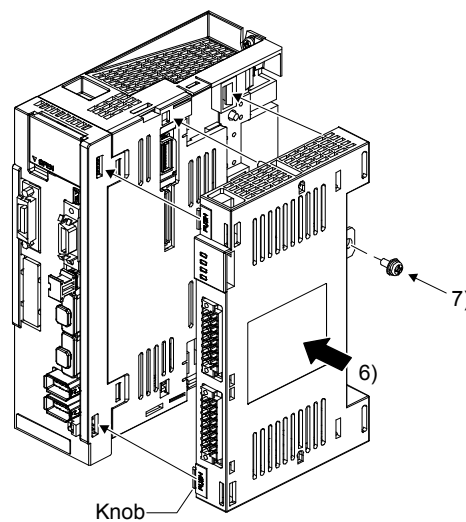

- 6) Push the four corners of the side of the MR-D01 simultaneously to the control interface until the four clips click so that the CN7 and CN9 connectors are connected straight.
7) Fix with the screws which have been removed in 3).

5. MR-J4-DU_(-RJ) DRIVE UNIT

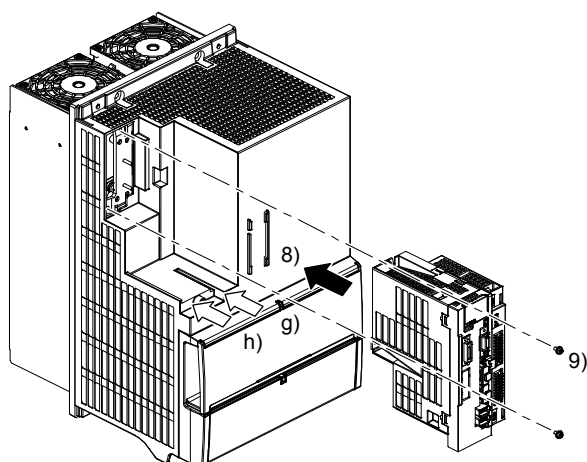

- 8) Install the control interface on the drive unit along the guide lines (g, h)). Confirm that the model name and the serial numbers on the plate of the drive unit correspond, and that those of the control interface correspond. If the model names and the serial numbers do not correspond, alarms or malfunction may occur.
- 9) Fix with the screws which have been removed in 1).

(2) Removing the MR-D30

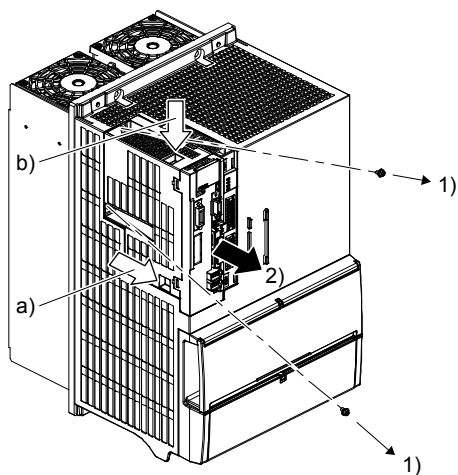

- 1) Remove the mounting screw.
- 2) Fit your fingers in a) and b) to pull the control interface off the drive unit in the arrow direction. Do not pull without removing the mounting screws.

5. MR-J4-DU_(-RJ) DRIVE UNIT

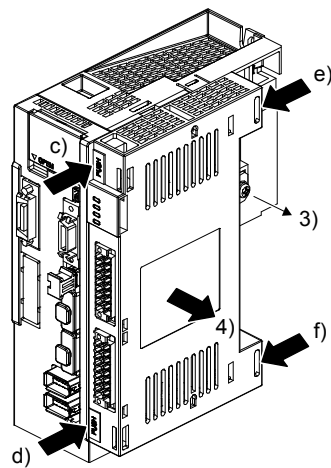

- 3) Remove the mounting screw.
- 4) While pushing the clips (c), d), e), f)), pull out the MR-D30 in the arrow direction. Do not pull the MR-D30 without removing the mounting screws.

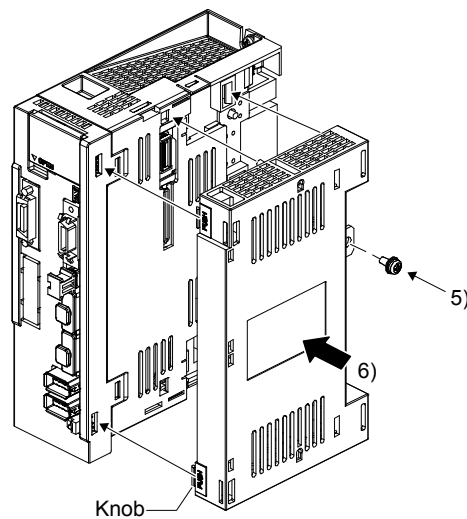

- 5) Push the four corners of the case simultaneously to the control interface until the four clips click.
- 6) Fix with the screws which have been removed in 3).

5. MR-J4-DU_(-RJ) DRIVE UNIT

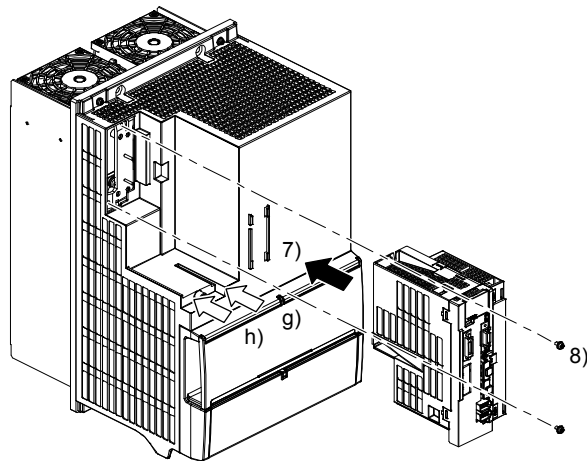

- 7) Install the control interface on the drive unit along the guide lines (g, h)). Confirm that the model name and the serial numbers on the plate of the drive unit correspond, and that those of the control interface correspond. If the model names and the serial numbers do not correspond, alarms or malfunction may occur.
- 8) Fix with the screws which have been removed in 1).

5.5.2 MR-J4-DU30K_-RJ to MR-J4-DU37K_-RJ/MR-J4-DU30K_4-RJ to MR-J4-DU55K_4-RJ



CAUTION ● Avoid touching burr remained after the part a) being cut off from the case c) shown in the figure below. Otherwise, it may cause injury.

(1) Mounting the MR-D30

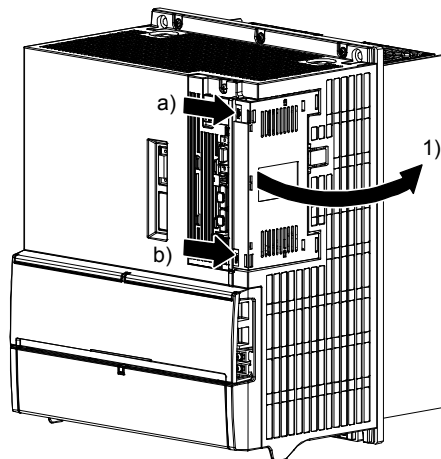

- 1) While pushing the clips (a) , b)), and pull out the side cover in the arrow direction.

5. MR-J4-DU_(-RJ) DRIVE UNIT

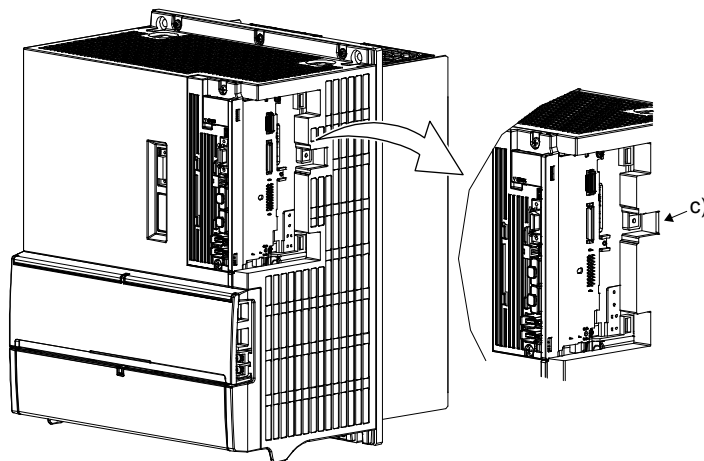

- 2) When mounting the MR-D30 for the first time, cut off the part a) from the case after removing the side cover. When cutting off the part c), be careful not to damage the case of the drive unit. After the part a) is cut off, inside of the drive unit will be exposed even after the side cover or the MR-D30 is attached. Prevent foreign materials from entering through the opened area into the drive unit.

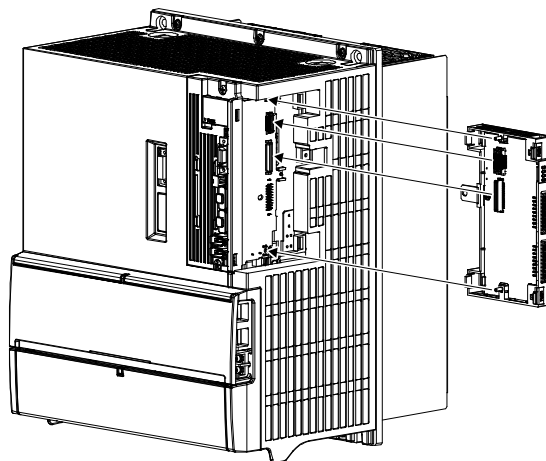

- 3) Insert the guide pins of the MR-D30 in the guide holes located on the side of the drive unit.

5. MR-J4-DU_(-RJ) DRIVE UNIT

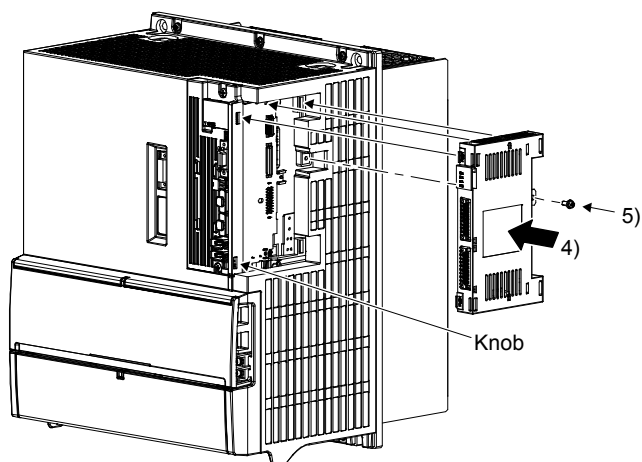

- 4) Push the four corners of the side of the MR-D01 simultaneously to the control interface until the four clips click so that the CN7 and CN9 connectors are connected straight.
- 5) Fix the unit on the MR-D30 with the enclosed mounting screws (M4).

(2) Removing the MR-D30

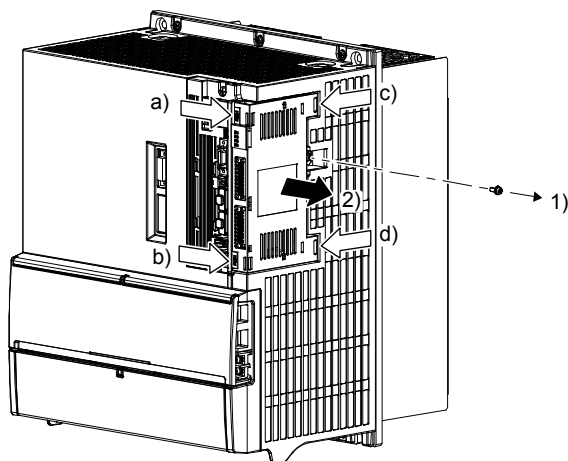

- 1) Remove the mounting screw.
- 2) While pushing the clips (a), b), c), d)), pull out the MR-D30 in the arrow direction. Do not pull the MR-D30 without removing the mounting screws.

5. MR-J4-DU_(-RJ) DRIVE UNIT

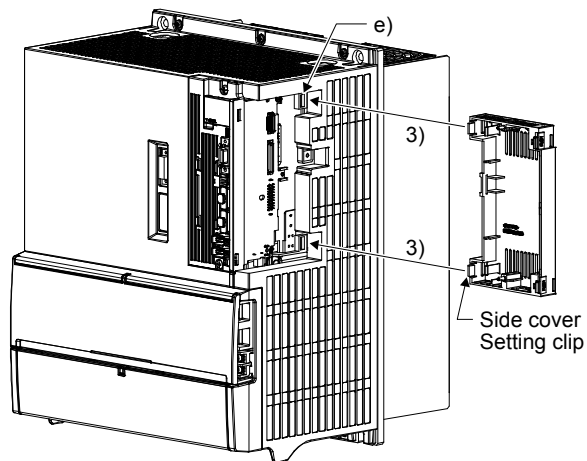

- 3) Insert the side cover setting clips into the recesses e) of the drive unit.

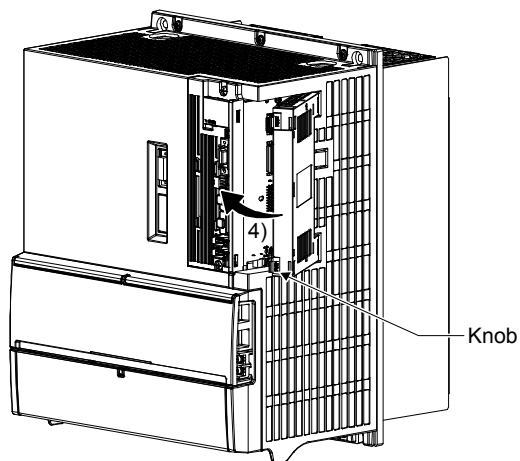

- 4) Push against the drive unit at the supporting point e) shown in procedure 1) until the clips clip into place.

6. TROUBLESHOOTING

6. TROUBLESHOOTING

6.1 MR-CV_ Power regeneration converter unit

When an error occurs during operation, the corresponding alarm or warning is displayed. When an alarm or warning is displayed, refer to "MELSERVO-J4 Servo Amplifier Instruction Manual (Troubleshooting)" to remove the failure. When an alarm occurs, ALM will turn off.

6.1.1 Explanation for the lists

(1) No./Name

Indicates each No./Name of alarms or warnings.

(2) Alarm deactivation

After its cause has been removed, the alarm can be deactivated by any of the methods marked ○ in the alarm deactivation column. Warnings are automatically canceled after the cause of occurrence is removed. Alarms are deactivated by alarm reset, CPU reset, or power cycling.

Alarm deactivation	Explanation
Alarm reset	1. Turn on RES (Reset) with an input device. (Note 1) 2. Input the servo-on command for the drive unit connected with the protection coordination cable.
CPU reset	Reset the controller itself. (Note 2)
Cycling the power	Turning the power off and then turning it on again.

Note 1. Deactivate the alarm in servo-off status. If the alarm is deactivated in servo-on status, [AL. 1B Converter error] occurs.

2. When it is not connected by a protection coordination cable, alarms cannot be deactivated by CPU reset.

6.1.2 Alarm/warning list

	Display	Name	Alarm deactivation		
			Alarm reset	CPU reset	Cycling the power
Alarm	61	Overcurrent		○	○
	62	Frequency error		○	○
	66	Process error		○	○
	67	Open phase		○	○
	68	Watchdog			○
	69	Ground fault	○	○	○
	6A	MC drive circuit error		○	○
	6B	Inrush current suppression circuit error		○	○
	6C	Main circuit error		○	○
	6E_ (Note 1)	Board error			○
	70	Converter forced stop error		○	○
	71	Undervoltage	○	○	○
	72	Cooling fan error		○	○
	73	Regenerative error	○ (Note 2)	○ (Note 2)	○ (Note 2)
	75	Overvoltage	○	○	○
	76	Switch setting error			○
	77	Main circuit device overheat		○ (Note 2)	○ (Note 2)
	7E	Overload 1	○ (Note 2)	○ (Note 2)	○ (Note 2)
7F	Overload 2	○ (Note 2)	○ (Note 2)	○ (Note 2)	

	Display	Name
	EA	Converter forced stop warning
	EB	Excessive regeneration warning
	EC	Overload warning
	EE	Cooling fan speed reduction warning

Note 1. The third digit may be displayed. Remedies for the alarm is the same as those for [AL. 6E].

2. After resolving the source of trouble, cool the equipment for approximately 30 minutes.

6. TROUBLESHOOTING

6.2 MR-CR_ Resistance regeneration converter unit

POINT
●[AL. 37 Parameter error] and warnings are not recorded in the alarm history.

When an error occurs during operation, the corresponding alarm or warning is displayed. When an alarm or warning is displayed, refer to "MELSERVO-J4 Servo Amplifier Instruction Manual (Troubleshooting)" to remove the failure. When an alarm occurs, ALM will turn off.

6.2.1 Explanation for the lists

(1) No./Name

Indicates each No./Name of alarms or warnings.

(2) Alarm deactivation

After its cause has been removed, the alarm can be deactivated by any of the methods marked ○ in the alarm deactivation column. Warnings are automatically canceled after the cause of occurrence is removed. Alarms are deactivated with alarm reset or cycling the power.

Alarm deactivation	Explanation
Alarm reset	Push "SET" on the current alarm screen of the display.
Cycling the power	Turning the power off and then turning it on again.

6.2.2 Alarm/warning list

	Display	Name	Alarm deactivation	
			Alarm reset	Cycling the power
Alarm	A.10	Undervoltage	○	○
	A.12	Memory error 1 (RAM)	▤	○
	A.15	Memory error 2 (EEP-ROM)	▤	○
	A.17	Board error	▤	○
	A.19	Memory error 3 (Flash-ROM)	▤	○
	A.30	Regenerative error	(Note)○	(Note)○
	A.33	Overvoltage	○	○
	A.37	Parameter error	▤	○
	A.38	MC drive circuit error	▤	○
	A.39	Open phase	▤	○
	A.3A	Inrush current suppression circuit error	▤	○
	A.45	Main circuit device overheat	(Note)○	(Note)○
	A.47	Cooling fan error	▤	○
	A.50	Overload 1	(Note)○	(Note)○
	A.51	Overload 2	(Note)○	(Note)○
	888	Watchdog	▤	○

	Display	Name
Warning	A.91	Converter overheat warning
	A.E0	Excessive regeneration warning
	A.E1	Overload warning 1
	A.E6	Converter forced stop warning
	A.E8	Cooling fan speed reduction warning

Note. After resolving the source of trouble, cool the equipment for approximately 30 minutes.

6. TROUBLESHOOTING

6.3 Drive unit

POINT
<ul style="list-style-type: none"> ● As soon as an alarm occurs, turn SON (Servo-on) off and interrupt the power. ● [AL. 37 Parameter error] and warnings (except [AL. F0 Tough drive warning]) are not recorded in the alarm history.

When an error occurs during operation, the corresponding alarm or warning is displayed. When an alarm or warning is displayed, refer to "MELSERVO-J4 Servo Amplifier Instruction Manual (Troubleshooting)" to remove the failure. When an alarm occurs, ALM (Malfunction) will turn off.

6.3.1 Explanation for the lists

(1) No./Name/Detail No./Detail name

Indicates each No./Name/Detail No./Detail name of alarms or warnings.

(2) Stop method

For the alarms and warnings in which "SD" is written in the stop method column, the servo motor stops with the dynamic brake after forced stop deceleration. For the alarms and warnings in which "DB" is written in the stop method column, the servo motor stops with the dynamic brake without forced stop deceleration.

(3) Alarm deactivation

After its cause has been removed, the alarm can be deactivated by any of the methods marked ○ in the alarm deactivation column. Warnings are automatically canceled after the cause of occurrence is removed. Alarms are deactivated with alarm reset, CPU reset, or cycling the power.

(a) MR-J4-DU_A_(-RJ)/MR-J4-DU_A_(-RJ)

Alarm deactivation	Explanation
Alarm reset	<ol style="list-style-type: none"> 1. Turning on RES (Reset) with input device 2. Pushing the "SET" button while the display of the drive unit is the current alarm display status 3. Click "Occurring Alarm Reset" in the "Alarm Display" window of MR Configurator2
Cycling the power	Turning the power off and then turning it on again.

(b) MR-J4-_B_(-RJ010)/MR-J4W_-_B_/MR-J4-DU_B_(-RJ)/MR-J4-_GF_(-RJ)

Alarm deactivation	Explanation
Alarm reset	<ol style="list-style-type: none"> 1. Error reset command from controller 2. Click "Occurring Alarm Reset" in the "Alarm Display" window of MR Configurator2
CPU reset	Resetting the controller itself
Cycling the power	Turning the power off and then turning it on again.

(4) Alarm code (Only MR-J4-DU_A_(-RJ))

Alarm codes are outputted only from MR-J4-DU_A_(-RJ). To output alarm codes, set [Pr. PD34] to "_ _ _ 1" when using a MR-J4-DU_A_(-RJ). Alarm codes are outputted by on/off of bit 0 to bit 2. Warnings ([AL. 90] to [AL. F3]) do not have alarm codes. The alarm codes in the following table will be outputted when they occur. The alarm codes will not be outputted in normal condition.

6. TROUBLESHOOTING

6.3.2 Alarm list

	No.	Name	Detail No.	Detail name	Stop method (Note 2, 3)	Alarm deactivation			Processing system (Note 9)	Stop system (Note 9)	Alarm code (Note 8)			
						Alarm reset	CPU reset	Cycling the power			ACD3 (Bit 3)	ACD2 (Bit 2)	ACD1 (Bit 1)	ACD0 (Bit 0)
Alarm	10	Undervoltage	10.1	Voltage drop in the control circuit power	DB	○	○	○	Common	All axes	0	0	1	0
			10.2	Voltage drop in the main circuit power	SD	○	○	○	Common	All axes				
	11	Switch setting error	11.1	Axis number setting error/ Station number setting error	DB	△	△	○	Common	All axes	△	△	△	△
			11.2	Disabling control axis setting error	DB	△	△	○	Common	All axes	△	△	△	△
	12	Memory error 1 (RAM)	12.1	RAM error 1	DB	△	△	○	Common	All axes	0	0	0	0
			12.2	RAM error 2	DB	△	△	○	Common	All axes				
			12.3	RAM error 3	DB	△	△	○	Common	All axes				
			12.4	RAM error 4	DB	△	△	○	Common	All axes				
			12.5	RAM error 5	DB	△	△	○	Common	All axes				
			12.6	RAM error 6	DB	△	△	○	Common	All axes				
	13	Clock error	13.1	Clock error 1	DB	△	△	○	Common	All axes	0	0	0	0
			13.2	Clock error 2	DB	△	△	○	Common	All axes				
	14	Control process error	14.1	Control process error 1	DB	△	△	○	Common	All axes	0	0	0	0
			14.2	Control process error 2	DB	△	△	○	Common	All axes				
			14.3	Control process error 3	DB	△	△	○	Common	All axes				
			14.4	Control process error 4	DB	△	△	○	Common	All axes				
			14.5	Control process error 5	DB	△	△	○	Common	All axes				
			14.6	Control process error 6	DB	△	△	○	Common	All axes				
			14.7	Control process error 7	DB	△	△	○	Common	All axes				
			14.8	Control process error 8	DB	△	△	○	Common	All axes				
			14.9	Control process error 9	DB	△	△	○	Common	All axes				
			14.A	Control process error 10	DB	△	△	○	Common	All axes				
			14.B	Control process error 11	DB	△	△	○	Common	All axes				
	15	Memory error 2 (EEP-ROM)	15.1	EEP-ROM error at power on	DB	△	△	○	Common	All axes	0	0	0	0
			15.2	EEP-ROM error during operation	DB	△	△	○	Common	All axes				
			15.4	Home position information read error	DB	△	△	○	Common	All axes				
	16	Encoder initial communication error 1	16.1	Encoder initial communication - Receive data error 1	DB	△	△	○	Each axis	Each axis	0	1	1	0
			16.2	Encoder initial communication - Receive data error 2	DB	△	△	○	Each axis	Each axis				
			16.3	Encoder initial communication - Receive data error 3	DB	△	△	○	Each axis	Each axis				
			16.5	Encoder initial communication - Transmission data error 1	DB	△	△	○	Each axis	Each axis				
			16.6	Encoder initial communication - Transmission data error 2	DB	△	△	○	Each axis	Each axis				
16.7			Encoder initial communication - Transmission data error 3	DB	△	△	○	Each axis	Each axis					
16.A			Encoder initial communication - Process error 1	DB	△	△	○	Each axis	Each axis					
16.B			Encoder initial communication - Process error 2	DB	△	△	○	Each axis	Each axis					
16.C			Encoder initial communication - Process error 3	DB	△	△	○	Each axis	Each axis					
16.D			Encoder initial communication - Process error 4	DB	△	△	○	Each axis	Each axis					
16.E			Encoder initial communication - Process error 5	DB	△	△	○	Each axis	Each axis					
16.F			Encoder initial communication - Process error 6	DB	△	△	○	Each axis	Each axis					

6. TROUBLESHOOTING

	No.	Name	Detail No.	Detail name	Stop method (Note 2, 3)	Alarm deactivation			Processing system (Note 9)	Stop system (Note 9)	Alarm code (Note 8)			
						Alarm reset	CPU reset	Cycling the power			ACD3 (Bit 3)	ACD2 (Bit 2)	ACD1 (Bit 1)	ACD0 (Bit 0)
Alarm	17	Board error	17.1	Board error 1	DB	<input checked="" type="checkbox"/>	<input checked="" type="checkbox"/>	<input type="checkbox"/>	Common	All axes	0	0	0	0
			17.3	Board error 2	DB	<input checked="" type="checkbox"/>	<input checked="" type="checkbox"/>	<input type="checkbox"/>	Common	All axes				
			17.4	Board error 3	DB	<input checked="" type="checkbox"/>	<input checked="" type="checkbox"/>	<input type="checkbox"/>	Common	All axes				
			17.5	Board error 4	DB	<input checked="" type="checkbox"/>	<input checked="" type="checkbox"/>	<input type="checkbox"/>	Common	All axes				
			17.6	Board error 5	DB	<input checked="" type="checkbox"/>	<input checked="" type="checkbox"/>	<input type="checkbox"/>	Common	All axes				
			17.7	Board error 7	DB	<input checked="" type="checkbox"/>	<input checked="" type="checkbox"/>	<input type="checkbox"/>						
			17.8	Board error 6 (Note 6)	DB	<input checked="" type="checkbox"/>	<input checked="" type="checkbox"/>	<input type="checkbox"/>	Common	All axes				
	19	Memory error 3 (Flash-ROM)	19.1	Flash-ROM error 1	DB	<input checked="" type="checkbox"/>	<input checked="" type="checkbox"/>	<input type="checkbox"/>	Common	All axes	0	0	0	0
			19.2	Flash-ROM error 2	DB	<input checked="" type="checkbox"/>	<input checked="" type="checkbox"/>	<input type="checkbox"/>	Common	All axes				
			19.3	Flash-ROM error 3	DB	<input checked="" type="checkbox"/>	<input checked="" type="checkbox"/>	<input type="checkbox"/>						
	1A	Servo motor combination error	1A.1	Servo motor combination error 1	DB	<input checked="" type="checkbox"/>	<input checked="" type="checkbox"/>	<input type="checkbox"/>	Each axis	Each axis	0	1	1	0
			1A.2	Servo motor control mode combination error	DB	<input checked="" type="checkbox"/>	<input checked="" type="checkbox"/>	<input type="checkbox"/>	Each axis	Each axis				
			1A.4	Servo motor combination error 2	DB	<input checked="" type="checkbox"/>	<input checked="" type="checkbox"/>	<input type="checkbox"/>	Each axis	Each axis				
	1B	Converter error	1B.1	Converter unit error	DB	<input checked="" type="checkbox"/>	<input checked="" type="checkbox"/>	<input type="checkbox"/>			0	0	1	0
	1E	Encoder initial communication error 2	1E.1	Encoder malfunction	DB	<input checked="" type="checkbox"/>	<input checked="" type="checkbox"/>	<input type="checkbox"/>	Each axis	Each axis	0	1	1	0
			1E.2	Load-side encoder malfunction	DB	<input checked="" type="checkbox"/>	<input checked="" type="checkbox"/>	<input type="checkbox"/>	Each axis	Each axis				
	1F	Encoder initial communication error 3	1F.1	Incompatible encoder	DB	<input checked="" type="checkbox"/>	<input checked="" type="checkbox"/>	<input type="checkbox"/>	Each axis	Each axis	0	1	1	0
			1F.2	Incompatible load-side encoder	DB	<input checked="" type="checkbox"/>	<input checked="" type="checkbox"/>	<input type="checkbox"/>	Each axis	Each axis				
	20	Encoder normal communication error 1	20.1	Encoder normal communication - Receive data error 1	DB	<input checked="" type="checkbox"/>	<input checked="" type="checkbox"/>	<input type="checkbox"/>	Each axis	Each axis	0	1	1	0
			20.2	Encoder normal communication - Receive data error 2	DB	<input checked="" type="checkbox"/>	<input checked="" type="checkbox"/>	<input type="checkbox"/>	Each axis	Each axis				
			20.3	Encoder normal communication - Receive data error 3	DB	<input checked="" type="checkbox"/>	<input checked="" type="checkbox"/>	<input type="checkbox"/>	Each axis	Each axis				
20.5			Encoder normal communication - Transmission data error 1	DB	<input checked="" type="checkbox"/>	<input checked="" type="checkbox"/>	<input type="checkbox"/>	Each axis	Each axis					
20.6			Encoder normal communication - Transmission data error 2	DB	<input checked="" type="checkbox"/>	<input checked="" type="checkbox"/>	<input type="checkbox"/>	Each axis	Each axis					
20.7			Encoder normal communication - Transmission data error 3	DB	<input checked="" type="checkbox"/>	<input checked="" type="checkbox"/>	<input type="checkbox"/>	Each axis	Each axis					
20.9			Encoder normal communication - Receive data error 4	DB	<input checked="" type="checkbox"/>	<input checked="" type="checkbox"/>	<input type="checkbox"/>	Each axis	Each axis					
20.A			Encoder normal communication - Receive data error 5	DB	<input checked="" type="checkbox"/>	<input checked="" type="checkbox"/>	<input type="checkbox"/>	Each axis	Each axis					
21	Encoder normal communication error 2	21.1	Encoder data error 1	DB	<input checked="" type="checkbox"/>	<input checked="" type="checkbox"/>	<input type="checkbox"/>	Each axis	Each axis	0	1	1	0	
		21.2	Encoder data update error	DB	<input checked="" type="checkbox"/>	<input checked="" type="checkbox"/>	<input type="checkbox"/>	Each axis	Each axis					
		21.3	Encoder data waveform error	DB	<input checked="" type="checkbox"/>	<input checked="" type="checkbox"/>	<input type="checkbox"/>	Each axis	Each axis					
		21.4	Encoder non-signal error	DB	<input checked="" type="checkbox"/>	<input checked="" type="checkbox"/>	<input type="checkbox"/>	Each axis	Each axis					
		21.5	Encoder hardware error 1	DB	<input checked="" type="checkbox"/>	<input checked="" type="checkbox"/>	<input type="checkbox"/>	Each axis	Each axis					
		21.6	Encoder hardware error 2	DB	<input checked="" type="checkbox"/>	<input checked="" type="checkbox"/>	<input type="checkbox"/>	Each axis	Each axis					
		21.9	Encoder data error 2	DB	<input checked="" type="checkbox"/>	<input checked="" type="checkbox"/>	<input type="checkbox"/>	Each axis	Each axis					

6. TROUBLESHOOTING

	No.	Name	Detail No.	Detail name	Stop method (Note 2, 3)	Alarm deactivation			Processing system (Note 9)	Stop system (Note 9)	Alarm code (Note 8)			
						Alarm reset	CPU reset	Cycling the power			ACD3 (Bit 3)	ACD2 (Bit 2)	ACD1 (Bit 1)	ACD0 (Bit 0)
Alarm	24	Main circuit error	24.1	Ground fault detected by hardware detection circuit	DB	/	/	○	Each axis	All axes	1	1	0	0
			24.2	Ground fault detected by software detection function	DB	○	○	○	Each axis	All axes	1	1	0	0
	25	Absolute position erased	25.1	Servo motor encoder - Absolute position erased	DB	/	/	○	Each axis	Each axis	1	1	1	0
			25.2	Scale measurement encoder - Absolute position erased	DB	/	/	○	Each axis	Each axis	1	1	1	0
	27	Initial magnetic pole detection error	27.1	Initial magnetic pole detection - Abnormal termination	DB	○	/	○	Each axis	Each axis	1	1	1	0
			27.2	Initial magnetic pole detection - Time out error	DB	○	/	○	Each axis	Each axis				
			27.3	Initial magnetic pole detection - Limit switch error	DB	○	/	○	Each axis	Each axis				
			27.4	Initial magnetic pole detection - Estimated error	DB	○	/	○	Each axis	Each axis				
			27.5	Initial magnetic pole detection - Position deviation error	DB	○	/	○	Each axis	Each axis				
			27.6	Initial magnetic pole detection - Speed deviation error	DB	○	/	○	Each axis	Each axis				
	28	Linear encoder error 2	28.1	Linear encoder - Environment error	DB	/	/	○	Each axis	Each axis	0	1	1	0
			2A	Linear encoder error 1	2A.1	Linear encoder error 1-1	DB	/	/	○	Each axis	Each axis	0	1
	2A.2	Linear encoder error 1-2			DB	/	/	○	Each axis	Each axis				
	2A.3	Linear encoder error 1-3			DB	/	/	○	Each axis	Each axis				
	2A.4	Linear encoder error 1-4			DB	/	/	○	Each axis	Each axis				
	2A.5	Linear encoder error 1-5			DB	/	/	○	Each axis	Each axis				
	2A.6	Linear encoder error 1-6			DB	/	/	○	Each axis	Each axis				
	2A.7	Linear encoder error 1-7			DB	/	/	○	Each axis	Each axis				
	2A.8	Linear encoder error 1-8			DB	/	/	○	Each axis	Each axis				
	2B	Encoder counter error	2B.1	Encoder counter error 1	DB	/	/	○	Each axis	Each axis	1	1	1	0
			2B.2	Encoder counter error 2	DB	/	/	○	Each axis	Each axis	1	1	1	0
	30	Regenerative error	30.1	Regeneration heat error	DB	○ (Note 1)	○ (Note 1)	○ (Note 1)	Common	All axes	0	0	0	1
			30.2	Regeneration signal error	DB	○ (Note 1)	○ (Note 1)	○ (Note 1)	Common	All axes				
			30.3	Regeneration feedback signal error	DB	○ (Note 1)	○ (Note 1)	○ (Note 1)	Common	All axes				
31	Overspeed	31.1	Abnormal motor speed	SD	○	○	○	Each axis	Each axis	0	1	0	1	
32	Overcurrent	32.1	Overcurrent detected at hardware detection circuit (during operation)	DB	/	/	○	Each axis	All axes	0	1	0	0	
		32.2	Overcurrent detected at software detection function (during operation)	DB	○	○	○	Each axis	All axes					
		32.3	Overcurrent detected at hardware detection circuit (during a stop)	DB	/	/	○	Each axis	All axes					
		32.4	Overcurrent detected at software detection function (during a stop)	DB	○	○	○	Each axis	All axes					
33	Overvoltage	33.1	Main circuit voltage error	DB	○	○	○	Common	All axes	1	0	0	1	

6. TROUBLESHOOTING

	No.	Name	Detail No.	Detail name	Stop method (Note 2, 3)	Alarm deactivation			Processing system (Note 9)	Stop system (Note 9)	Alarm code (Note 8)			
						Alarm reset	CPU reset	Cycling the power			ACD3 (Bit 3)	ACD2 (Bit 2)	ACD1 (Bit 1)	ACD0 (Bit 0)
Alarm	34	SSCNET receive error 1	34.1	SSCNET receive data error	SD	○	○ (Note 5)	○	Common	All axes	/	/	/	/
			34.2	SSCNET connector connection error	SD	○	○	○	Common	All axes	/	/	/	/
			34.3	SSCNET communication data error	SD	○	○	○	Each axis	Each axis	/	/	/	/
			34.4	Hardware error signal detection	SD	○	○	○	Common	All axes	/	/	/	/
			34.5	SSCNET receive data error (safety observation function)	SD	○	○	○	/	/	/	/	/	/
			34.6	SSCNET communication data error (safety observation function)	SD	○	○	○	/	/	/	/	/	/
	35	Command frequency error	35.1	Command frequency error	SD	○	○	○	Each axis	Each axis	1	1	0	1
	36	SSCNET receive error 2	36.1	Continuous communication data error	SD	○	○	○	Each axis	Each axis	/	/	/	/
			36.2	Continuous communication data error (safety observation function)	SD	○	○	○	/	/	/	/	/	/
	37	Parameter error	37.1	Parameter setting range error	DB	/	○	○	Each axis	Each axis	/	/	/	/
			37.2	Parameter combination error	DB	/	○	○	Each axis	Each axis	1	0	0	0
			37.3	Point table setting error	DB	/	/	○	/	/	/	/	/	/
	39	Program error	39.1	Program error	DB	/	/	○	/	/	/	/	/	/
			39.2	Instruction argument external error	DB	/	/	○	/	/	0	0	0	0
			39.3	Register No. error	DB	/	/	○	/	/	/	/	/	/
			39.4	Non-correspondence instruction error	DB	/	/	○	/	/	/	/	/	/
	3A	Inrush current suppression circuit error	3A.1	Inrush current suppression circuit error	DB	/	/	○	Common	All axes	0	0	0	0
	3D	Parameter setting error for driver communication	3D.1	Parameter combination error for driver communication on slave	DB	/	/	○	/	/	/	/	/	/
			3D.2	Parameter combination error for driver communication on master	DB	/	/	○	/	/	/	/	/	/
	3E	Operation mode error	3E.1	Operation mode error	DB	/	○	○	Each axis	Each axis	/	/	/	/
			3E.6	Operation mode switch error	DB	/	/	○	/	/	1	0	0	0
	42	Servo control error (for linear servo motor and direct drive motor)	42.1	Servo control error by position deviation	DB	(Note 4)	(Note 4)	○	Each axis	Each axis	/	/	/	/
			42.2	Servo control error by speed deviation	DB	(Note 4)	(Note 4)	○	Each axis	Each axis	/	/	/	/
			42.3	Servo control error by torque/thrust deviation	DB	(Note 4)	(Note 4)	○	Each axis	Each axis	/	/	/	/
Fully closed loop control error (for fully closed loop control)		42.8	Fully closed loop control error by position deviation	DB	(Note 4)	(Note 4)	○	Each axis	Each axis	0	1	1	0	
		42.9	Fully closed loop control error by speed deviation	DB	(Note 4)	(Note 4)	○	Each axis	Each axis	/	/	/	/	
		42.A	Fully closed loop control error by position deviation during command stop	DB	(Note 4)	(Note 4)	○	Each axis	Each axis	/	/	/	/	
45	Main circuit device overheat	45.1	Main circuit device overheat error 1	SD	○ (Note 1)	○ (Note 1)	○ (Note 1)	Common	All axes	0	0	1	1	
		45.2	Main circuit device overheat error 2	SD	○ (Note 1)	○ (Note 1)	○ (Note 1)	Common	All axes	/	/	/	/	

6. TROUBLESHOOTING

	No.	Name	Detail No.	Detail name	Stop method (Note 2, 3)	Alarm deactivation			Processing system (Note 9)	Stop system (Note 9)	Alarm code (Note 8)			
						Alarm reset	CPU reset	Cycling the power			ACD3 (Bit 3)	ACD2 (Bit 2)	ACD1 (Bit 1)	ACD0 (Bit 0)
Alarm	46	Servo motor overheat	46.1	Abnormal temperature of servo motor 1	SD	○ (Note 1)	○ (Note 1)	○ (Note 1)	Each axis	Each axis	0	0	1	1
			46.2	Abnormal temperature of servo motor 2	SD	○ (Note 1)	○ (Note 1)	○ (Note 1)	Each axis	Each axis				
			46.3	Thermistor disconnected error	SD	○ (Note 1)	○ (Note 1)	○ (Note 1)	Each axis	Each axis				
			46.4	Thermistor circuit error	SD	○ (Note 1)	○ (Note 1)	○ (Note 1)	Each axis	Each axis				
			46.5	Abnormal temperature of servo motor 3	DB	○ (Note 1)	○ (Note 1)	○ (Note 1)	Each axis	Each axis				
			46.6	Abnormal temperature of servo motor 4	DB	○ (Note 1)	○ (Note 1)	○ (Note 1)	Each axis	Each axis				
	47	Cooling fan error	47.1	Cooling fan stop error	SD	△	△	○	Common	All axes	0	0	1	1
			47.2	Cooling fan speed reduction error	SD	△	△	○	Common	All axes				
	50	Overload 1	50.1	Thermal overload error 1 during operation	SD	○ (Note 1)	○ (Note 1)	○ (Note 1)	Each axis	Each axis	0	0	1	1
			50.2	Thermal overload error 2 during operation	SD	○ (Note 1)	○ (Note 1)	○ (Note 1)	Each axis	Each axis				
			50.3	Thermal overload error 4 during operation	SD	○ (Note 1)	○ (Note 1)	○ (Note 1)	Each axis	Each axis				
			50.4	Thermal overload error 1 during a stop	SD	○ (Note 1)	○ (Note 1)	○ (Note 1)	Each axis	Each axis				
			50.5	Thermal overload error 2 during a stop	SD	○ (Note 1)	○ (Note 1)	○ (Note 1)	Each axis	Each axis				
			50.6	Thermal overload error 4 during a stop	SD	○ (Note 1)	○ (Note 1)	○ (Note 1)	Each axis	Each axis				
	51	Overload 2	51.1	Thermal overload error 3 during operation	DB	○ (Note 1)	○ (Note 1)	○ (Note 1)	Each axis	Each axis	0	0	1	1
			51.2	Thermal overload error 3 during a stop	DB	○ (Note 1)	○ (Note 1)	○ (Note 1)	Each axis	Each axis				
	52	Error excessive	52.1	Excess droop pulse 1	SD	○	○	○	Each axis	Each axis	0	1	0	1
			52.3	Excess droop pulse 2	SD	○	○	○	Each axis	Each axis				
			52.4	Error excessive during 0 torque limit	SD	○	○	○	Each axis	Each axis				
			52.5	Excess droop pulse 3	DB	○	○	○	Each axis	Each axis				
	54	Oscillation detection	54.1	Oscillation detection error	DB	○	○	○	Each axis	Each axis	0	0	1	1
	56	Forced stop error	56.2	Over speed during forced stop	DB	○	○	○	Each axis	Each axis	0	1	1	0
			56.3	Estimated distance over during forced stop	DB	○	○	○	Each axis	Each axis				
	61	Operation error	61.1	Point table setting range error	DB	○	△	○	△	△	0	1	0	1
	63	STO timing error	63.1	STO1 off	DB	○	○	○	Common	All axes	0	1	1	0
			63.2	STO2 off	DB	○	○	○	Common	All axes				
63.5			STO by functional safety unit	DB	○	○	○	△	△					
64	Functional safety unit setting error	64.1	STO input error	DB	△	△	○	△	△	1	0	0	0	
		64.2	Compatibility mode setting error	DB	△	△	○	△	△					
		64.3	Operation mode setting error	DB	△	△	○	△	△					

6. TROUBLESHOOTING

	No.	Name	Detail No.	Detail name	Stop method (Note 2, 3)	Alarm deactivation			Processing system (Note 9)	Stop system (Note 9)	Alarm code (Note 8)			
						Alarm reset	CPU reset	Cycling the power			ACD3 (Bit 3)	ACD2 (Bit 2)	ACD1 (Bit 1)	ACD0 (Bit 0)
Alarm	65	Functional safety unit connection error	65.1	Functional safety unit communication error 1	SD	/	/	○	/	/	0	0	0	0
			65.2	Functional safety unit communication error 2	SD	/	/	○	/	/				
			65.3	Functional safety unit communication error 3	SD	/	/	○	/	/				
			65.4	Functional safety unit communication error 4	SD	/	/	○	/	/				
			65.5	Functional safety unit communication error 5	SD	/	/	○	/	/				
			65.6	Functional safety unit communication error 6	SD	/	/	○	/	/				
			65.7	Functional safety unit communication error 7	SD	/	/	○	/	/				
			65.8	Functional safety unit shut-off signal error 1	DB	/	/	○	/	/				
			65.9	Functional safety unit shut-off signal error 2	DB	/	/	○	/	/				
	66	Encoder initial communication error (safety observation function)	66.1	Encoder initial communication - Receive data error 1 (safety observation function)	DB	/	/	○	/	/	0	1	1	0
			66.2	Encoder initial communication - Receive data error 2 (safety observation function)	DB	/	/	○	/	/				
			66.3	Encoder initial communication - Receive data error 3 (safety observation function)	DB	/	/	○	/	/				
			66.7	Encoder initial communication - Transmission data error 1 (safety observation function)	DB	/	/	○	/	/				
			66.9	Encoder initial communication - Process error 1 (safety observation function)	DB	/	/	○	/	/				
	67	Encoder normal communication error 1 (safety observation function)	67.1	Encoder normal communication - Receive data error 1 (safety observation function)	DB	/	/	○	/	/	0	1	1	0
			67.2	Encoder normal communication - Receive data error 2 (safety observation function)	DB	/	/	○	/	/				
			67.3	Encoder normal communication - Receive data error 3 (safety observation function)	DB	/	/	○	/	/				
			67.4	Encoder normal communication - Receive data error 4 (safety observation function)	DB	/	/	○	/	/				
			67.7	Encoder normal communication - Transmission data error 1 (safety observation function)	DB	/	/	○	/	/				
	68	STO diagnosis error	68.1	Mismatched STO signal error	DB	/	/	○	Common	Common	0	0	0	0
	69	Command error	69.1	Forward rotation-side software limit detection - Command excess error	SD	○	○	○	/	/	/	/	/	/
			69.2	Reverse rotation-side software limit detection - Command excess error	SD	○	○	○	/	/	/	/	/	/
			69.3	Forward rotation stroke end detection - Command excess error	SD	○	○	○	/	/	/	/	/	/
			69.4	Reverse rotation stroke end detection - Command excess error	SD	○	○	○	/	/	/	/	/	/
			69.5	Upper stroke limit detection - Command excess error	SD	○	○	○	/	/	/	/	/	/
			69.6	Lower stroke limit detection - Command excess error	SD	○	○	○	/	/	/	/	/	/

6. TROUBLESHOOTING

	No.	Name	Detail No.	Detail name	Stop method (Note 2, 3)	Alarm deactivation			Processing system (Note 9)	Stop system (Note 9)	Alarm code (Note 8)			
						Alarm reset	CPU reset	Cycling the power			ACD3 (Bit 3)	ACD2 (Bit 2)	ACD1 (Bit 1)	ACD0 (Bit 0)
Alarm	70	Load-side encoder initial communication error 1	70.1	Load-side encoder initial communication - Receive data error 1	DB	/	/	○	Each axis	Each axis	0	1	1	0
			70.2	Load-side encoder initial communication - Receive data error 2	DB	/	/	○	Each axis	Each axis				
			70.3	Load-side encoder initial communication - Receive data error 3	DB	/	/	○	Each axis	Each axis				
			70.5	Load-side encoder initial communication - Transmission data error 1	DB	/	/	○	Each axis	Each axis				
			70.6	Load-side encoder initial communication - Transmission data error 2	DB	/	/	○	Each axis	Each axis				
			70.7	Load-side encoder initial communication - Transmission data error 3	DB	/	/	○	Each axis	Each axis				
			70.A	Load-side encoder initial communication - Process error 1	DB	/	/	○	Each axis	Each axis				
			70.B	Load-side encoder initial communication - Process error 2	DB	/	/	○	Each axis	Each axis				
			70.C	Load-side encoder initial communication - Process error 3	DB	/	/	○	Each axis	Each axis				
			70.D	Load-side encoder initial communication - Process error 4	DB	/	/	○	Each axis	Each axis				
			70.E	Load-side encoder initial communication - Process error 5	DB	/	/	○	Each axis	Each axis				
			70.F	Load-side encoder initial communication - Process error 6	DB	/	/	○	Each axis	Each axis				
			71	Load-side encoder normal communication error 1	71.1	Load-side encoder normal communication - Receive data error 1	DB	/	/	○				
	71.2	Load-side encoder normal communication - Receive data error 2			DB	/	/	○	Each axis	Each axis				
	71.3	Load-side encoder normal communication - Receive data error 3			DB	/	/	○	Each axis	Each axis				
	71.5	Load-side encoder normal communication - Transmission data error 1			DB	/	/	○	Each axis	Each axis				
	71.6	Load-side encoder normal communication - Transmission data error 2			DB	/	/	○	Each axis	Each axis				
	71.7	Load-side encoder normal communication - Transmission data error 3			DB	/	/	○	Each axis	Each axis				
	71.9	Load-side encoder normal communication - Receive data error 4			DB	/	/	○	Each axis	Each axis				
	71.A	Load-side encoder normal communication - Receive data error 5			DB	/	/	○	Each axis	Each axis				

6. TROUBLESHOOTING

	No.	Name	Detail No.	Detail name	Stop method (Note 2, 3)	Alarm deactivation			Processing system (Note 9)	Stop system (Note 9)	Alarm code (Note 8)			
						Alarm reset	CPU reset	Cycling the power			ACD3 (Bit 3)	ACD2 (Bit 2)	ACD1 (Bit 1)	ACD0 (Bit 0)
Alarm	72	Load-side encoder normal communication error 2	72.1	Load-side encoder data error 1	DB	/	/	○	Each axis	Each axis	0	1	1	0
			72.2	Load-side encoder data update error	DB	/	/	○	Each axis	Each axis				
			72.3	Load-side encoder data waveform error	DB	/	/	○	Each axis	Each axis				
			72.4	Load-side encoder non-signal error	DB	/	/	○	Each axis	Each axis				
			72.5	Load-side encoder hardware error 1	DB	/	/	○	Each axis	Each axis				
			72.6	Load-side encoder hardware error 2	DB	/	/	○	Each axis	Each axis				
			72.9	Load-side encoder data error 2	DB	/	/	○	Each axis	Each axis				
74	Option card error 1	74.1	Option card error 1	DB	/	/	○	/	/	/	/	/	/	/
		74.2	Option card error 2	DB	/	/	○	/	/	/	/	/	/	/
		74.3	Option card error 3	DB	/	/	○	/	/	/	/	/	/	/
		74.4	Option card error 4	DB	/	/	○	/	/	/	/	/	/	/
		74.5	Option card error 5	DB	/	/	○	/	/	/	/	/	/	/
75	Option card error 2	75.3	Option card connection error	DB	/	/	○	/	/	/	/	/	/	/
		75.4	Option card disconnected	DB	/	/	○	/	/	/	/	/	/	/
79	Functional safety unit diagnosis error	79.1	Functional safety unit power voltage error	DB	○ (Note 7)	/	○	/	/	/	1	1	1	1
		79.2	Functional safety unit internal error	DB	/	/	○	/	/					
		79.3	Abnormal temperature of functional safety unit	SD	○ (Note 7)	/	○	/	/					
		79.4	Servo amplifier error	SD	/	/	○	/	/					
		79.5	Input device error	SD	/	/	○	/	/					
		79.6	Output device error	SD	/	/	○	/	/					
		79.7	Mismatched input signal error	SD	/	/	○	/	/					
		79.8	Position feedback fixing error	DB	/	/	○	/	/					
7A	Parameter setting error (safety observation function)	7A.1	Parameter verification error (safety observation function)	DB	/	/	○	/	/	1	0	0	0	
		7A.2	Parameter setting range error (safety observation function)	DB	/	/	○	/	/					
		7A.3	Parameter combination error (safety observation function)	DB	/	/	○	/	/					
		7A.4	Functional safety unit combination error (safety observation function)	DB	/	/	○	/	/					
7B	Encoder diagnosis error (safety observation function)	7B.1	Encoder diagnosis error 1 (safety observation function)	DB	/	/	○	/	/	0	1	1	0	
		7B.2	Encoder diagnosis error 2 (safety observation function)	DB	/	/	○	/	/					
		7B.3	Encoder diagnosis error 3 (safety observation function)	DB	/	/	○	/	/					
		7B.4	Encoder diagnosis error 4 (safety observation function)	DB	/	/	○	/	/					
7C	Functional safety unit communication diagnosis error (safety observation function)	7C.1	Functional safety unit communication setting error (safety observation function)	SD	○ (Note 7)	○	○	/	/	0	0	0	0	
		7C.2	Functional safety unit communication data error (safety observation function)	SD	○ (Note 7)	○	○	/	/					
7D	Safety observation error	7D.1	Stop observation error	DB	○ (Note 3)	/	○	/	/	1	1	1	1	
		7D.2	Speed observation error	DB	○ (Note 7)	/	○	/	/					
82	Master-slave operation error 1	82.1	Master-slave operation error 1	DB	○	○	○	/	/	/	/	/	/	

6. TROUBLESHOOTING

	No.	Name	Detail No.	Detail name	Stop method (Note 2, 3)	Alarm deactivation			Processing system (Note 9)	Stop system (Note 9)	Alarm code (Note 8)			
						Alarm reset	CPU reset	Cycling the power			ACD3 (Bit 3)	ACD2 (Bit 2)	ACD1 (Bit 1)	ACD0 (Bit 0)
Alarm	84	Network module initialization error	84.1	Network module undetected error	DB	/	/	○	/	/	/	/	/	/
			84.2	Network module initialization error 1	DB	/	/	○	/	/	/	/	/	/
			84.3	Network module initialization error 2	DB	/	/	○	/	/	/	/	/	/
	85	Network module error	85.1	Network module error 1	SD	/	/	○	/	/	/	/	/	/
			85.2	Network module error 2	SD	/	/	○	/	/	/	/	/	/
			85.3	Network module error 3	SD	/	/	○	/	/	/	/	/	/
	86	Network communication error	86.1	Network communication error 1	SD	○	/	○	/	/	/	/	/	/
			86.2	Network communication error 2	SD	○	/	○	/	/	/	/	/	/
			86.3	Network communication error 3	SD	○	/	○	/	/	/	/	/	/
	8A	USB communication time-out error/serial communication time-out error/Modbus RTU communication time-out error	8A.1	USB communication time-out error/serial communication time-out error	SD	○	○	○	Common	All axes	0	0	0	0
			8A.2	Modbus RTU communication time-out error	SD	○	○	○	/	/	/	/	/	/
	8D	CC-Link IE communication error	8D.1	CC-Link IE communication error 1	SD	○	/	○	/	/	/	/	/	/
			8D.2	CC-Link IE communication error 2	SD	○	/	○	/	/	/	/	/	/
			8D.3	Master station setting error 1	DB	○	/	○	/	/	/	/	/	/
			8D.5	Master station setting error 2	DB	/	/	○	/	/	/	/	/	/
			8D.6	CC-Link IE communication error 3	SD	○	/	○	/	/	/	/	/	/
			8D.7	CC-Link IE communication error 4	SD	○	/	○	/	/	/	/	/	/
			8D.8	CC-Link IE communication error 5	SD	○	/	○	/	/	/	/	/	/
			8D.9	Synchronization error 1	SD	/	/	○	/	/	/	/	/	/
			8D.A	Synchronization error 2	SD	/	/	○	/	/	/	/	/	/
	8E	USB communication error/serial communication error/Modbus RTU communication error	8E.1	USB communication receive error/serial communication receive error	SD	○	○	○	Common	All axes	/	/	/	/
			8E.2	USB communication checksum error/serial communication checksum error	SD	○	○	○	Common	All axes	/	/	/	/
			8E.3	USB communication character error/serial communication character error	SD	○	○	○	Common	All axes	/	/	/	/
8E.4			USB communication command error/serial communication command error	SD	○	○	○	Common	All axes	0	0	0	0	
8E.5			USB communication data number error/serial communication data number error	SD	○	○	○	Common	All axes	/	/	/	/	
8E.6			Modbus RTU communication receive error	SD	○	○	○	/	/	/	/	/	/	
8E.7			Modbus RTU communication message frame error	SD	○	○	○	/	/	/	/	/	/	
8E.8			Modbus RTU communication CRC error	SD	○	○	○	/	/	/	/	/	/	
88888	Watchdog	8888_	Watchdog	DB	/	/	○	Common	All axes	/	/	/	/	

6. TROUBLESHOOTING

- Note
1. After resolving the source of trouble, cool the equipment for approximately 30 minutes.
 2. The following shows three stop methods of DB, and SD.
DB: Stops with dynamic brake.
Coasts for MR-J4-03A6(-RJ) and MR-J4W2-0303B6. Note that EDB is applied when an alarm below occurs;
[AL. 30.1], [AL. 32.2], [AL. 32.4], [AL. 51.1], [AL. 51.2], [AL. 888]
SD: Forced stop deceleration
 3. This is applicable when [Pr. PA04] is set to the initial value. The stop system of SD can be changed to DB using [Pr. PA04].
 4. The alarm can be canceled by setting as follows:
For the fully closed loop control: set [Pr. PE03] to "1 _ _ _".
When a linear servo motor or direct drive motor is used: set [Pr. PL04] to "1 _ _ _".
 5. In some controller communication status, the alarm factor may not be removed.
 6. This alarm will occur only in the J3 compatibility mode.
 7. Reset this while all the safety observation functions are stopped.
 8. Alarm codes are outputted only from MR-J4- _A_(-RJ)/MR-J4-DU _A_(-RJ).

6. TROUBLESHOOTING

6.3.3 Warning list

	No.	Name	Detail No.	Detail name	Stop method (Note 2, 3)	Processing system (Note 5)	Stop system (Note 5)
Warning	90	Home position return incomplete warning	90.1	Home position return incomplete			
			90.2	Home position return abnormal termination			
			90.5	Z-phase unpassed			
	91	Servo amplifier overheat warning (Note 1)	91.1	Main circuit device overheat warning		Common	
	92	Battery cable disconnection warning	92.1	Encoder battery cable disconnection warning		Each axis	
			92.3	Battery degradation		Each axis	
	93	ABS data transfer warning	93.1	ABS data transfer requirement warning during magnetic pole detection			
	95	STO warning	95.1	STO1 off detection	DB	Common	All axes
			95.2	STO2 off detection	DB	Common	All axes
			95.3	STO warning 1 (safety observation function)	DB		
			95.4	STO warning 2 (safety observation function)	DB		
			95.5	STO warning 3 (safety observation function)	DB		
	96	Home position setting warning	96.1	In-position warning at home positioning		Each axis	
			96.2	Command input warning at home positioning		Each axis	
			96.3	Servo off warning at home positioning			
			96.4	Home positioning warning during magnetic pole detection			
	97	Positioning specification warning	97.1	Program operation disabled warning			
			97.2	Next station position warning			
	98	Software limit warning	98.1	Forward rotation-side software stroke limit reached			
			98.2	Reverse rotation-side software stroke limit reached			
	99	Stroke limit warning	99.1	Forward rotation stroke end off	(Note 4, 7)		
			99.2	Reverse rotation stroke end off	(Note 4, 7)		
			99.4	Upper stroke limit off	(Note 7)	Each axis	
			99.5	Lower stroke limit off	(Note 7)	Each axis	
	9A	Optional unit input data error warning	9A.1	Optional unit input data sign error			
			9A.2	Optional unit BCD input data error			
	9B	Error excessive warning	9B.1	Excess droop pulse 1 warning		Each axis	
			9B.3	Excess droop pulse 2 warning		Each axis	
			9B.4	Error excessive warning during 0 torque limit		Each axis	
	9C	Converter error	9C.1	Converter unit error			
9D	CC-Link IE warning 1	9D.1	Station number switch change warning				
		9D.2	Master station setting warning				
		9D.3	Overlapping station number warning				
		9D.4	Mismatched station number warning				

6. TROUBLESHOOTING

	No.	Name	Detail No.	Detail name	Stop method (Note 2, 3)	Processing system (Note 5)	Stop system (Note 5)
Warning	9E	CC-Link IE warning 2	9E.1	CC-Link IE communication warning			
	9F	Battery warning	9F.1	Low battery		Each axis	
			9F.2	Battery degradation warning		Each axis	
	E0	Excessive regeneration warning	E0.1	Excessive regeneration warning		Common	
	E1	Overload warning 1	E1.1	Thermal overload warning 1 during operation		Each axis	
			E1.2	Thermal overload warning 2 during operation		Each axis	
			E1.3	Thermal overload warning 3 during operation		Each axis	
			E1.4	Thermal overload warning 4 during operation		Each axis	
			E1.5	Thermal overload error 1 during a stop		Each axis	
			E1.6	Thermal overload error 2 during a stop		Each axis	
			E1.7	Thermal overload error 3 during a stop		Each axis	
			E1.8	Thermal overload error 4 during a stop		Each axis	
	E2	Servo motor overheat warning	E2.1	Servo motor temperature warning		Each axis	
	E3	Absolute position counter warning	E3.1	Multi-revolution counter travel distance excess warning			
			E3.2	Absolute position counter warning		Each axis	
			E3.4	Absolute positioning counter EEPROM writing frequency warning			
			E3.5	Encoder absolute positioning counter warning		Each axis	
	E4	Parameter warning	E4.1	Parameter setting range error warning		Each axis	
	E5	ABS time-out warning	E5.1	Time-out during ABS data transfer			
			E5.2	ABSM off during ABS data transfer			
			E5.3	SON off during ABS data transfer			
	E6	Servo forced stop warning	E6.1	Forced stop warning	SD	Common	All axes
			E6.2	SS1 forced stop warning 1 (safety observation function)	SD		
			E6.3	SS1 forced stop warning 2 (safety observation function)	SD		
	E7	Controller forced stop warning	E7.1	Controller forced stop warning	SD	Common	All axes
	E8	Cooling fan speed reduction warning	E8.1	Decreased cooling fan speed warning		Common	
E8.2			Cooling fan stop		Common		
E9	Main circuit off warning	E9.1	Servo-on signal on during main circuit off	DB	Common	All axes	
		E9.2	Bus voltage drop during low speed operation	DB	Common	All axes	
		E9.3	Ready-on signal on during main circuit off	DB	Common	All axes	
		E9.4	Converter unit forced stop	DB			
EA	ABS servo-on warning	EA.1	ABS servo-on warning				
EB	The other axis error warning	EB.1	The other axis error warning	DB	Each axis	(Note 6)	
EC	Overload warning 2	EC.1	Overload warning 2		Each axis		

6. TROUBLESHOOTING

	No.	Name	Detail No.	Detail name	Stop method (Note 2, 3)	Processing system (Note 5)	Stop system (Note 5)
Warning	ED	Output watt excess warning	ED.1	Output watt excess warning	/	Each axis	/
	F0	Tough drive warning	F0.1	Instantaneous power failure tough drive warning	/	Each axis	/
			F0.3	Vibration tough drive warning	/	Each axis	/
	F2	Drive recorder - Miswriting warning	F2.1	Drive recorder - Area writing time-out warning	/	Common	/
			F2.2	Drive recorder - Data miswriting warning	/	Common	/
	F3	Oscillation detection warning	F3.1	Oscillation detection warning	/	Each axis	/
	F4	Positioning warning	F4.4	Target position setting range error warning	/	/	/
			F4.6	Acceleration time constant setting range error warning	/	/	/
			F4.7	Deceleration time constant setting range error warning	/	/	/
			F4.9	Home position return type error warning	/	/	/
	F5	Simple cam function - Cam data miswriting warning	F5.1	Cam data - Area writing time-out warning	/	/	/
			F5.2	Cam data - Area miswriting warning	/	/	/
			F5.3	Cam data checksum error	/	/	/
	F6	Simple cam function - Cam control warning	F6.1	Cam axis one cycle current value restoration failed	/	/	/
			F6.2	Cam axis feed current value restoration failed	/	/	/
			F6.3	Cam unregistered error	/	/	/
			F6.4	Cam control data setting range error	/	/	/
			F6.5	Cam No. external error	/	/	/
			F6.6	Cam control inactive	/	/	/
	F7	Machine diagnosis warning	F7.1	Vibration failure prediction warning	/	Each axis	/
			F7.2	Friction failure prediction warning	/	Each axis	/
F7.3			Total travel distance failure prediction warning	/	Each axis	/	

- Note
1. After resolving the source of trouble, cool the equipment for approximately 30 minutes.
 2. The following shows two stop methods of DB and SD.
DB: Stops with dynamic brake.
Coasts for MR-J4-03A6(-RJ) and MR-J4W2-0303B6.
SD: Forced stop deceleration
 3. This is applicable when [Pr. PA04] is set to the initial value. The stop system of SD can be changed to DB using [Pr. PA04].
 4. For MR-J4-_A_ servo amplifier (drive unit), quick stop or slow stop can be selected using [Pr. PD30].

7. DIMENSIONS

7. DIMENSIONS

POINT

● Refer to section 2.1 for the mounting hole process drawing.

7.1 MR-CV_ Power regeneration converter unit

7.1.1 MR-CV11K(4)/MR-CV18K(4)

[Unit: mm]

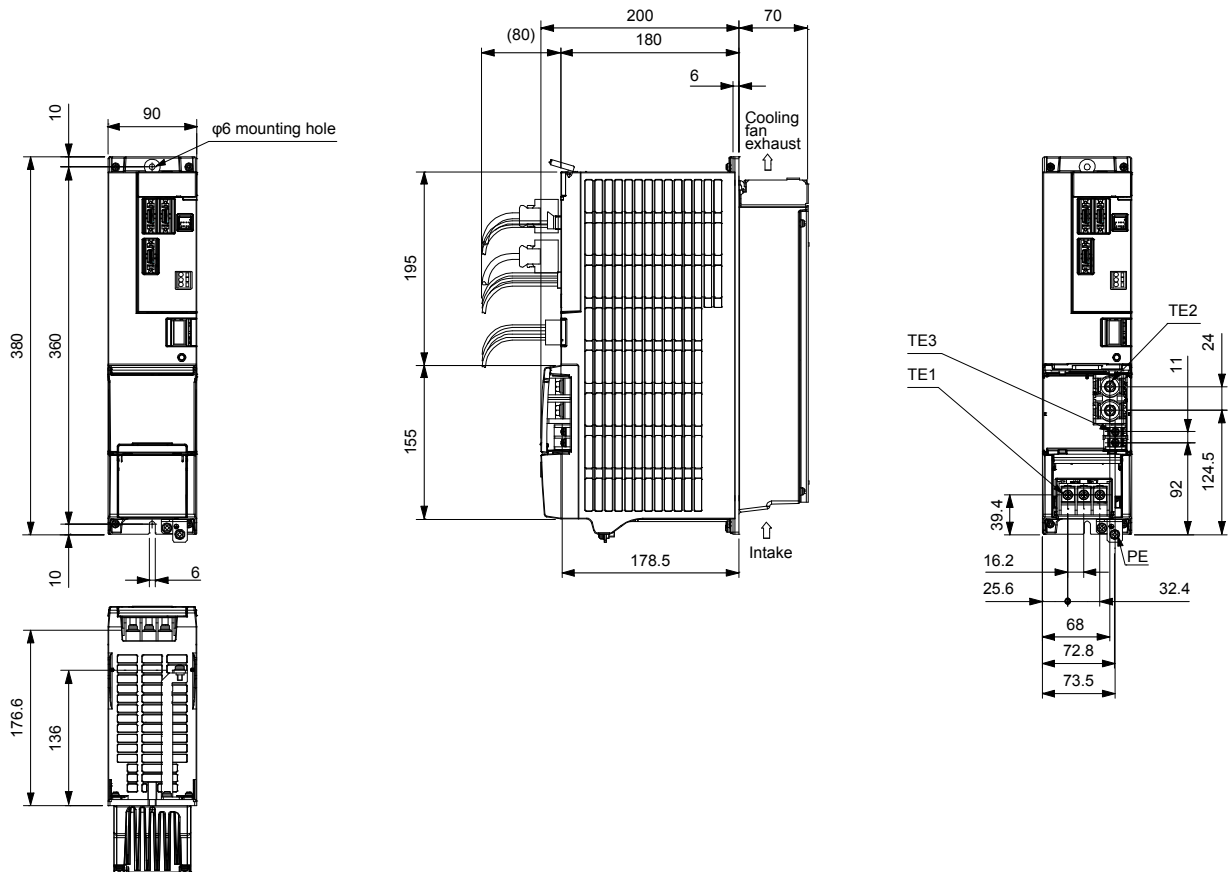

Mass: 6.1 [kg]

Mounting screw
Screw size: M5
Tightening torque: 3.24 [N•m]

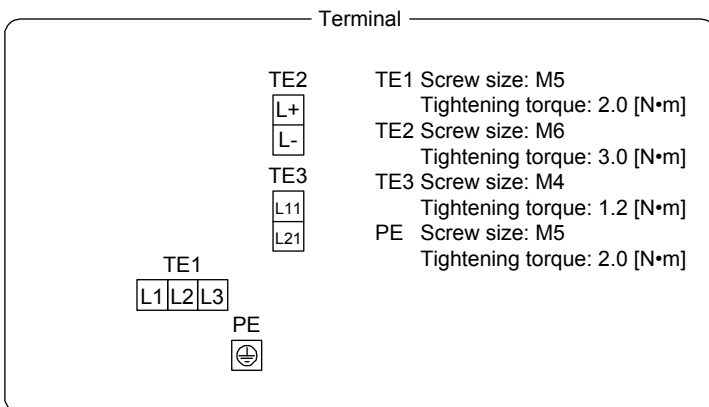

7. DIMENSIONS

7.1.2 MR-CV30K(4)/MR-CV37K(4)/MR-CV45K(4)

[Unit: mm]

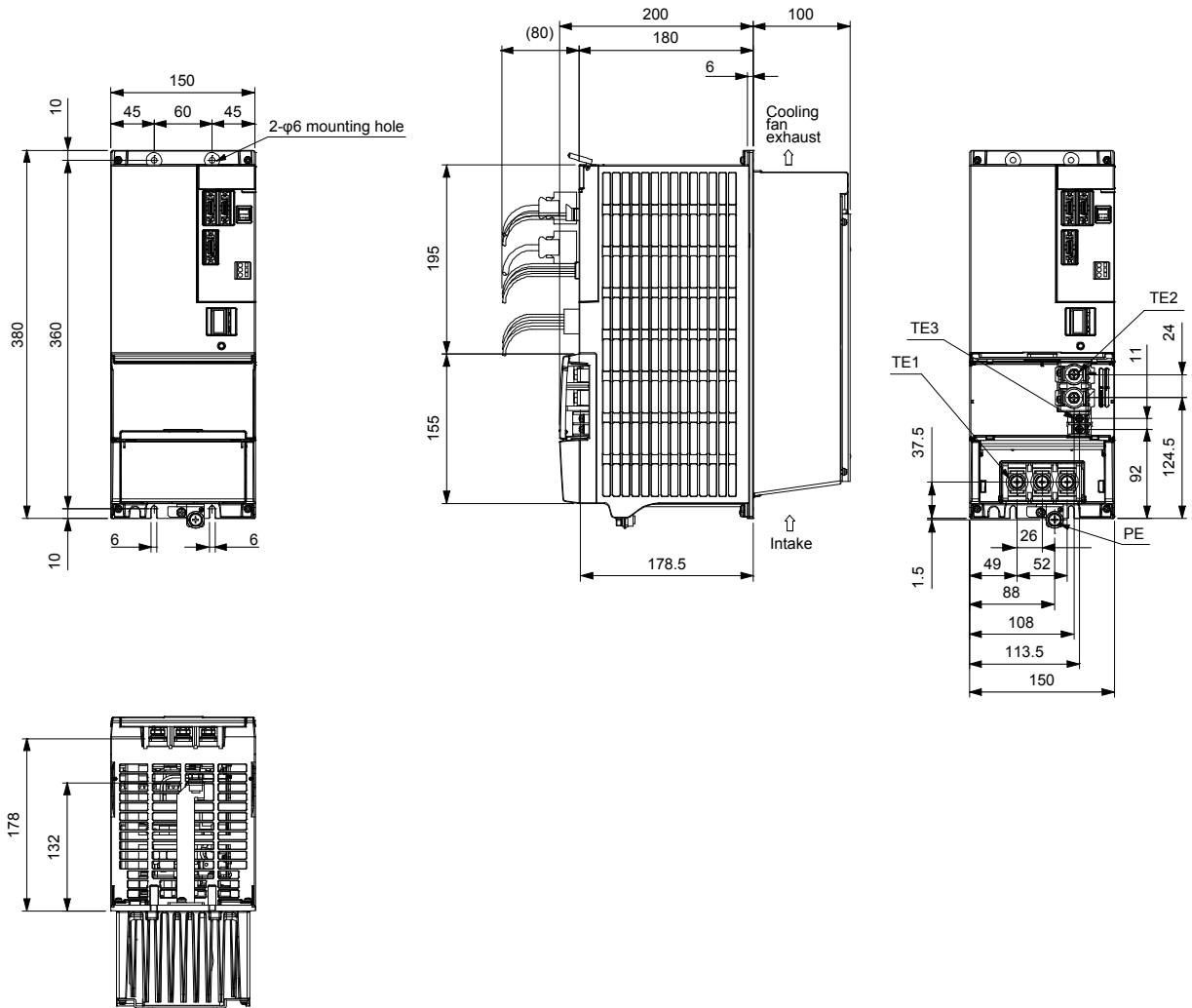

Mass: 12.1 [kg]

Mounting screw
Screw size: M5
Tightening torque: 3.24 [N•m]

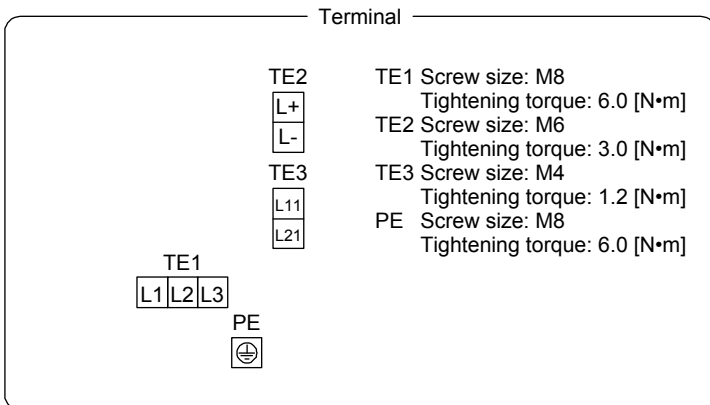

7. DIMENSIONS

7.1.3 MR-CV55K

[Unit: mm]

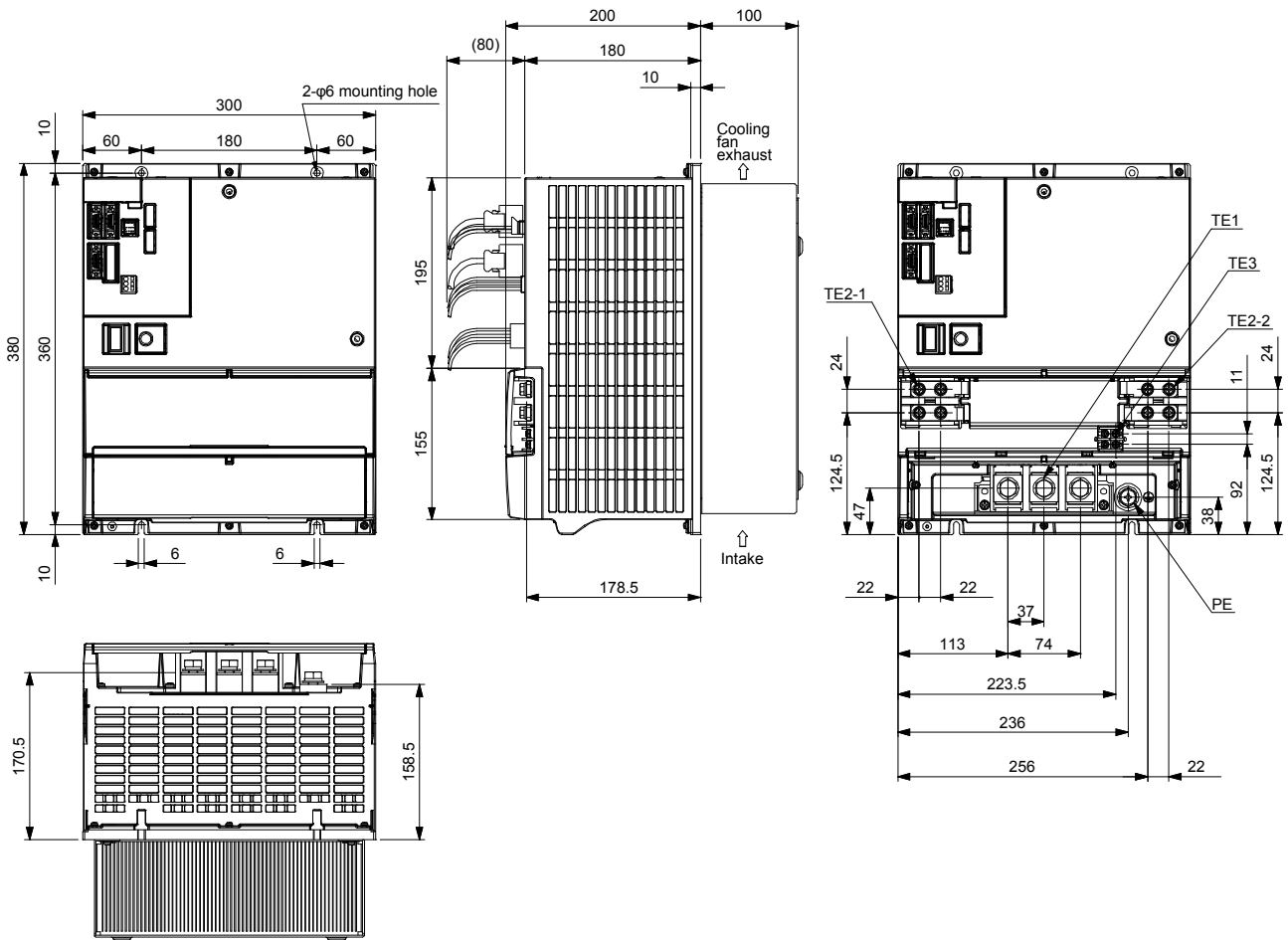

Mass: 25.0 [kg]

Mounting screw
Screw size: M5
Tightening torque: 3.24 [N•m]

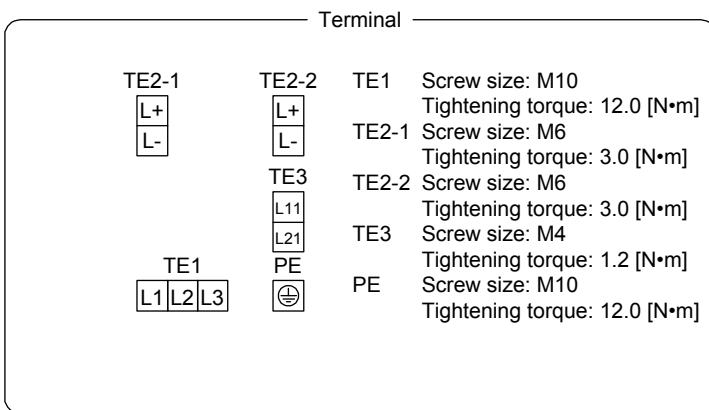

7. DIMENSIONS

7.1.4 MR-CV55K4/MR-CV75K4

[Unit: mm]

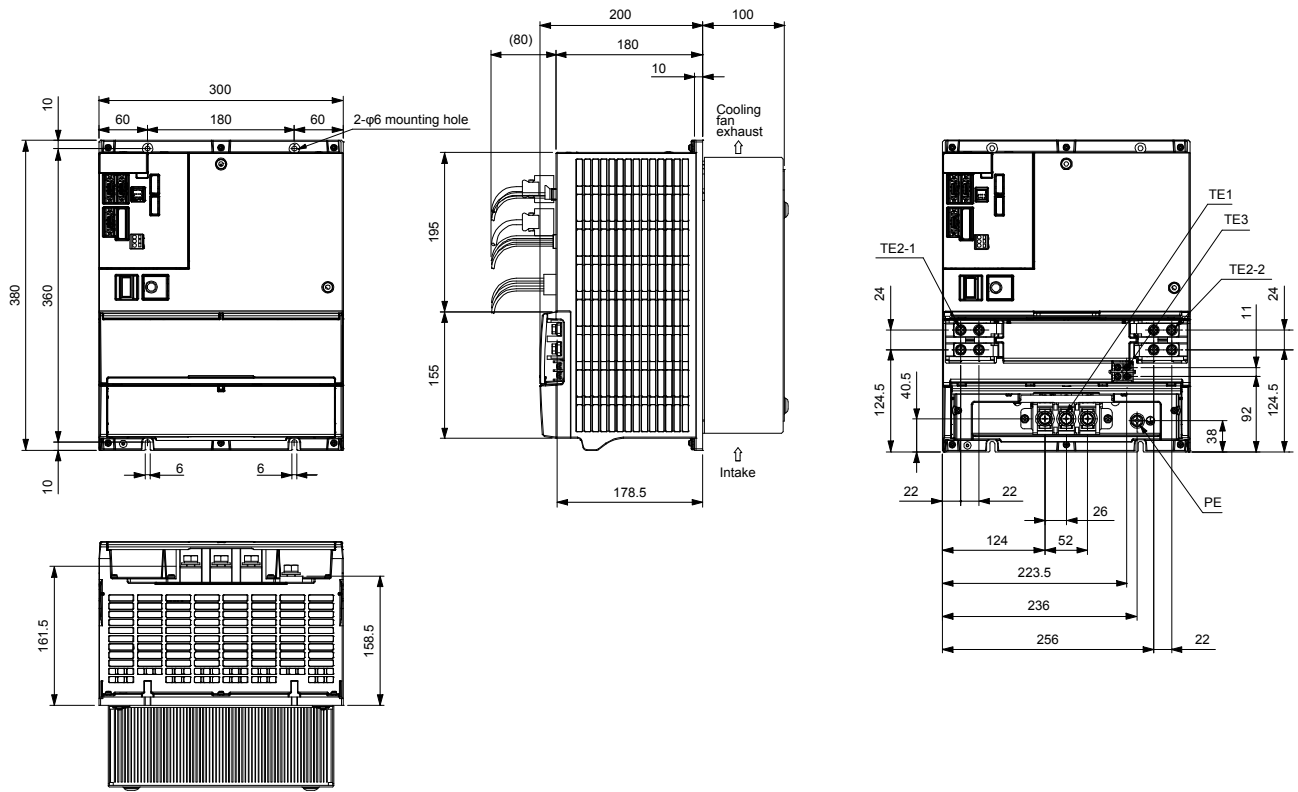

Terminal

TE2-1	TE2-2	TE1	Screw size: M8 Tightening torque: 6.0 [N•m]
L+	L+	TE2-1	Screw size: M6 Tightening torque: 3.0 [N•m]
L-	L-	TE2-2	Screw size: M6 Tightening torque: 3.0 [N•m]
	TE3	TE3	Screw size: M4 Tightening torque: 1.2 [N•m]
	L11	PE	Screw size: M8 Tightening torque: 6.0 [N•m]
	L21		
TE1	PE		
L1 L2 L3	⊕		

Mass: 25.0 [kg]

Mounting screw

Screw size: M5

Tightening torque: 3.24 [N•m]

7. DIMENSIONS

7.2 MR-CR55K(4) Resistance regeneration converter unit

[Unit: mm]

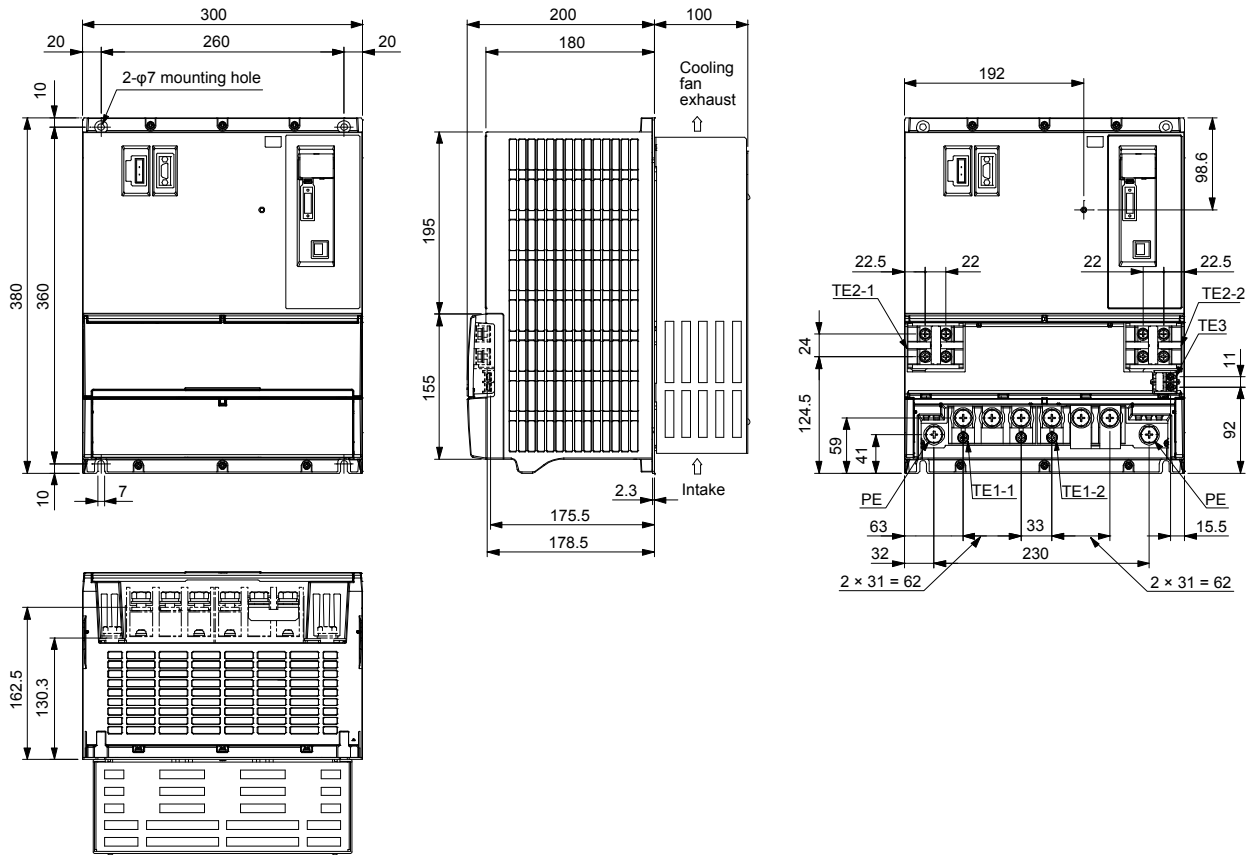

Mass: 22 [kg]

Mounting screw
Screw size: M6
Tightening torque: 5.49 [N•m]

Terminal

TE2-1	TE2-2	TE1-1	Screw size: M10 Tightening torque: 12.0 [N•m]
L+	L+	TE1-2	Screw size: M10 Tightening torque: 12.0 [N•m]
L-	L-	TE2-1	Screw size: M6 Tightening torque: 3.0 [N•m]
	TE3	TE2-2	Screw size: M6 Tightening torque: 3.0 [N•m]
	L11	TE3	Screw size: M4 Tightening torque: 1.2 [N•m]
	L21	PE	Screw size: M10 Tightening torque: 12.0 [N•m]
PE	TE1-1		
L1	L2		
L3	C		
P2	P1		

7. DIMENSIONS

7.3 Drive unit

7.3.1 MR-J4-DU_B_(-RJ)

POINT

● Only MR-J4-DU_B_-RJ is shown for dimensions. MR-J4-DU_B_ does not have CN2L connector. The dimensions of MR-J4-DU_B_ are the same as those of MR-J4-DU_B_-RJ except CN2L connector.

(1) MR-J4-DU900B(4)(-RJ)/MR-J4-DU11KB(4)(-RJ)

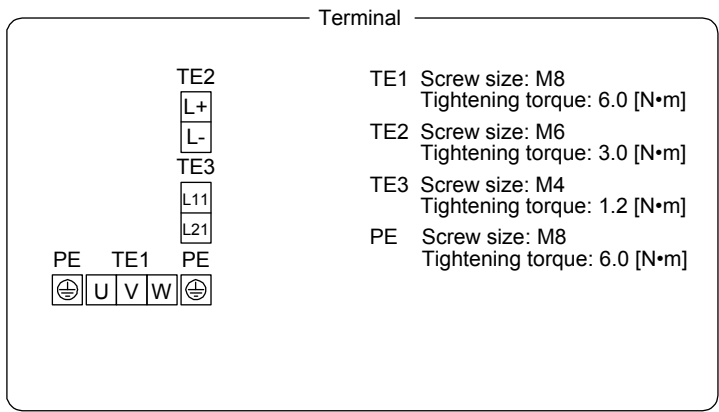
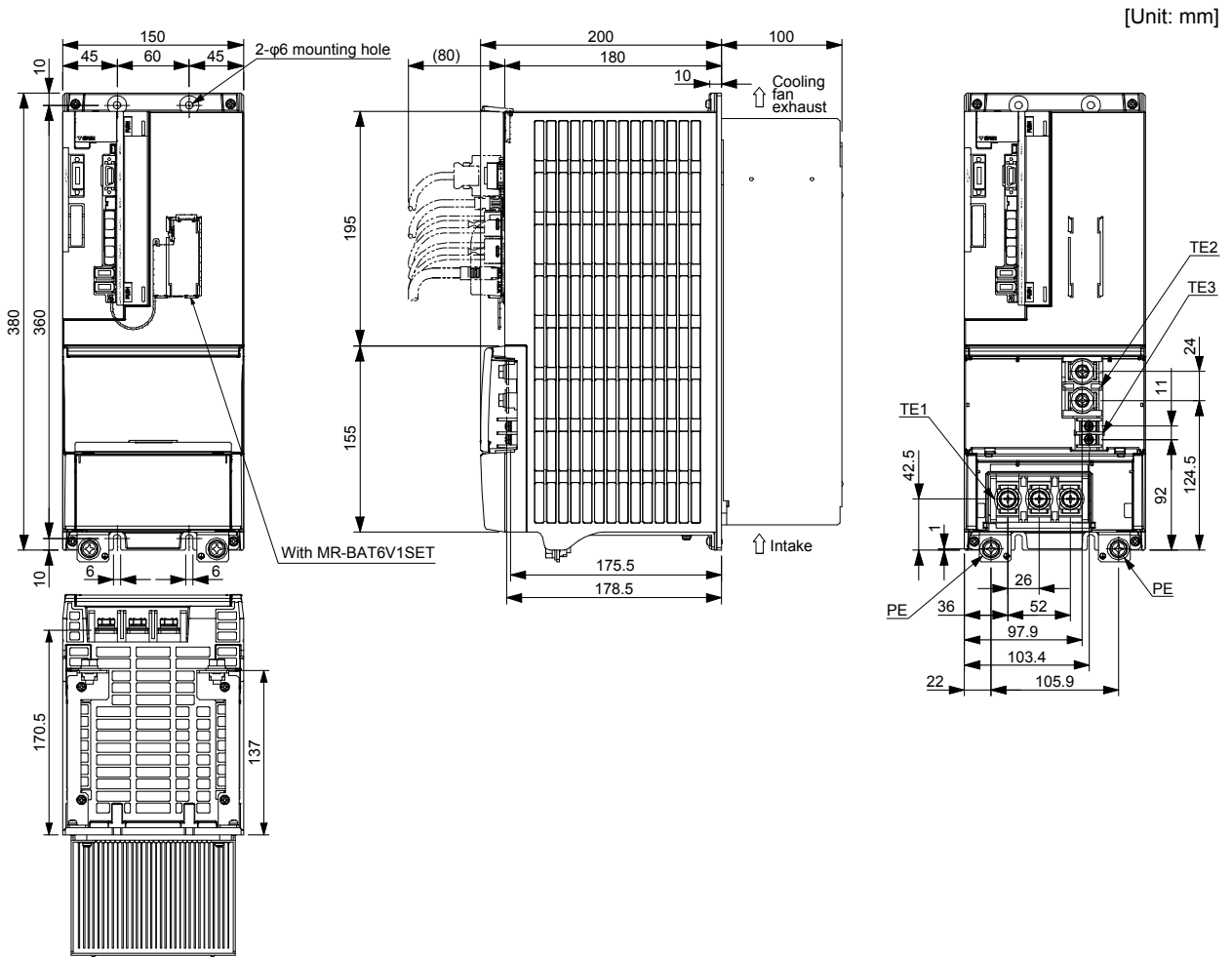

Mass: 9.9 [kg]

Mounting screw
Screw size: M5
Tightening torque: 3.24 [N•m]

7. DIMENSIONS

(2) MR-J4-DU15KB(4)(-RJ)/MR-J4-DU22KB(4)(-RJ)

[Unit: mm]

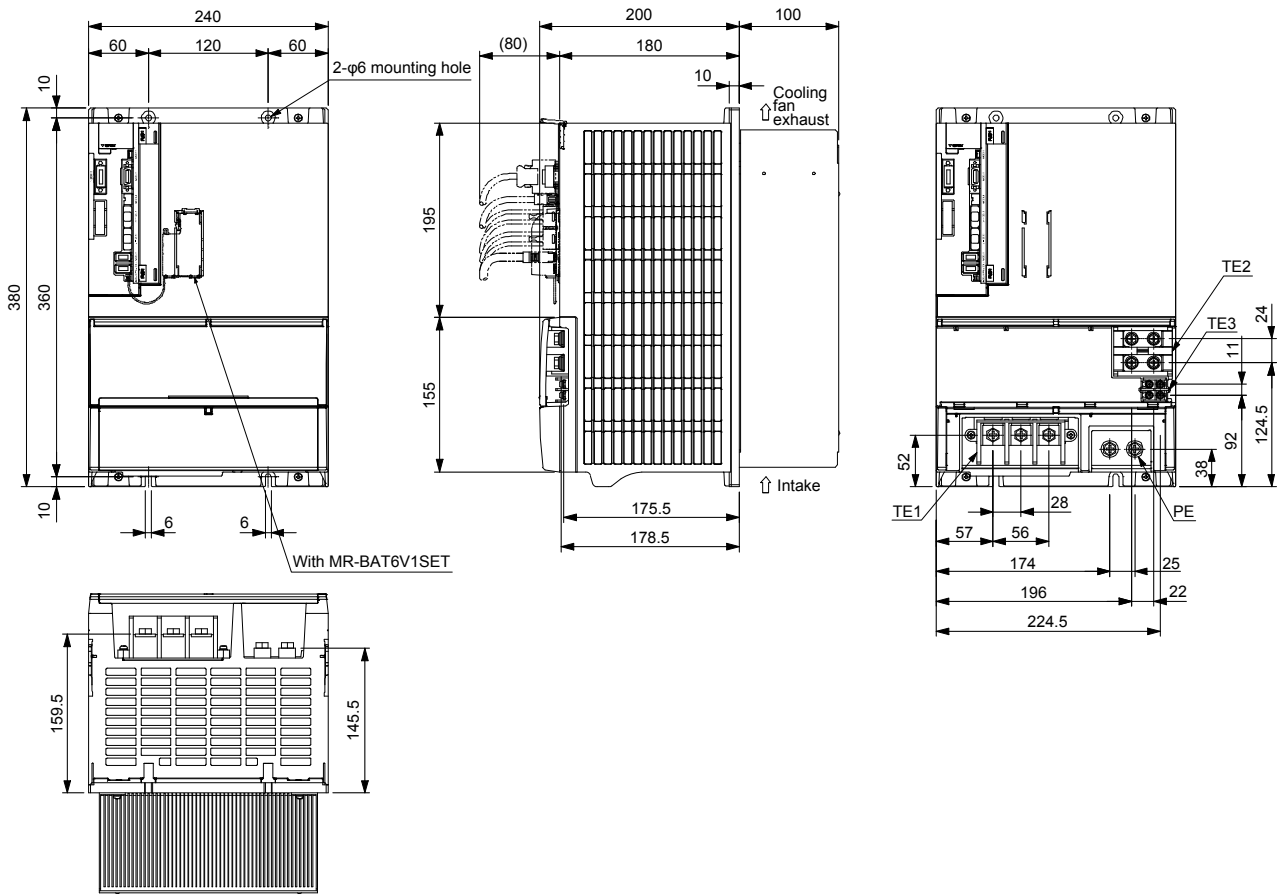

Mass: 15.2 [kg]

Mounting screw
Screw size: M5
Tightening torque: 3.24 [N·m]

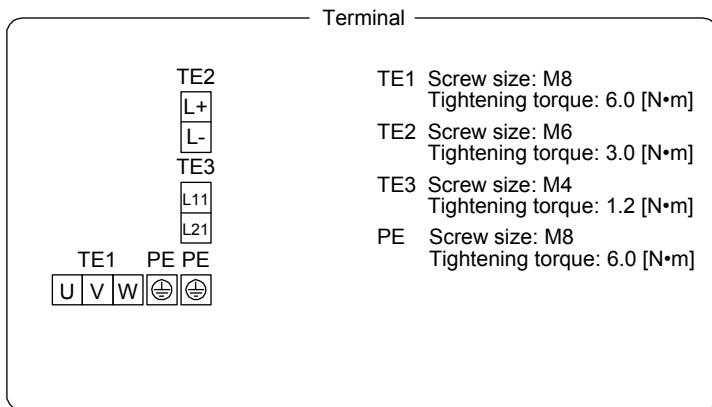

7. DIMENSIONS

(3) MR-J4-DU30KB(-RJ)/MR-J4-DU37KB(-RJ)/MR-J4-DU45KB4(-RJ)/MR-J4-DU55KB4(-RJ)

[Unit: mm]

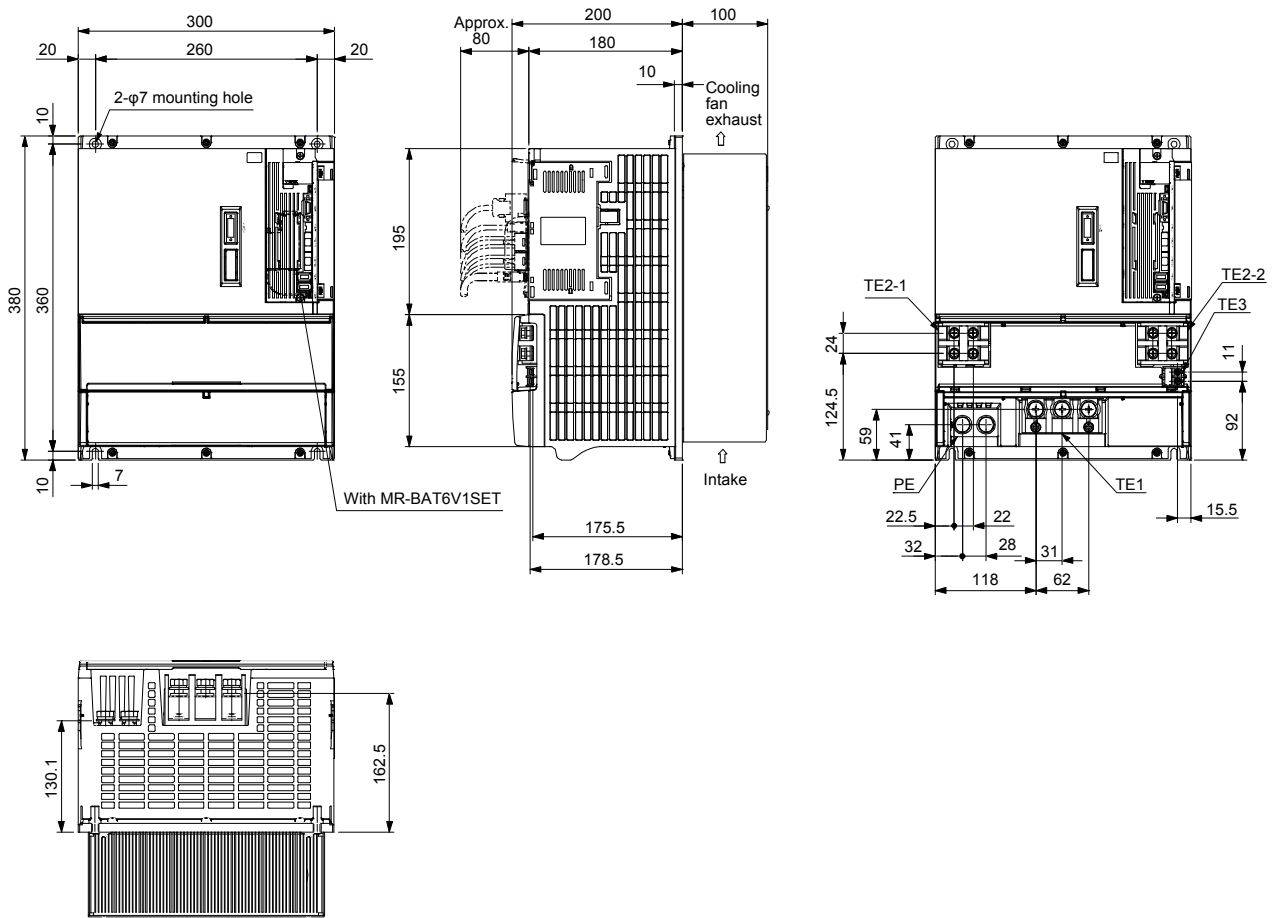

Mass: 21 [kg]

Mounting screw
Screw size: M6
Tightening torque: 5.49 [N·m]

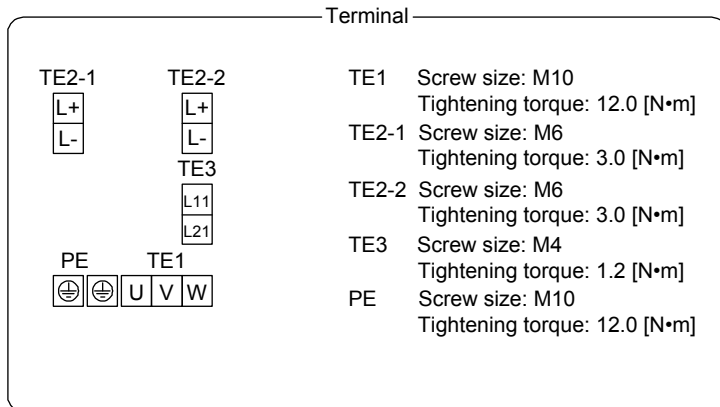

7. DIMENSIONS

(4) MR-J4-DU30KB4(-RJ)/MR-J4-DU37KB4(-RJ)

[Unit: mm]

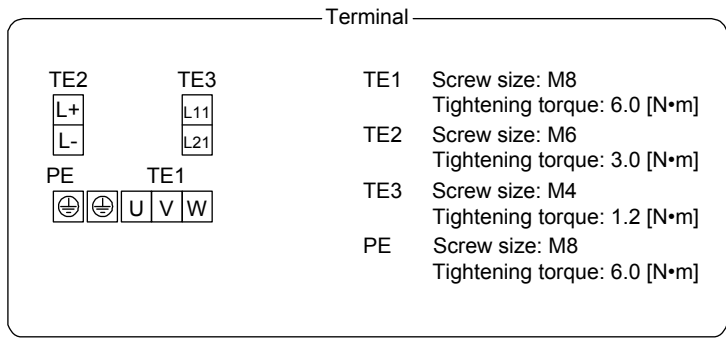
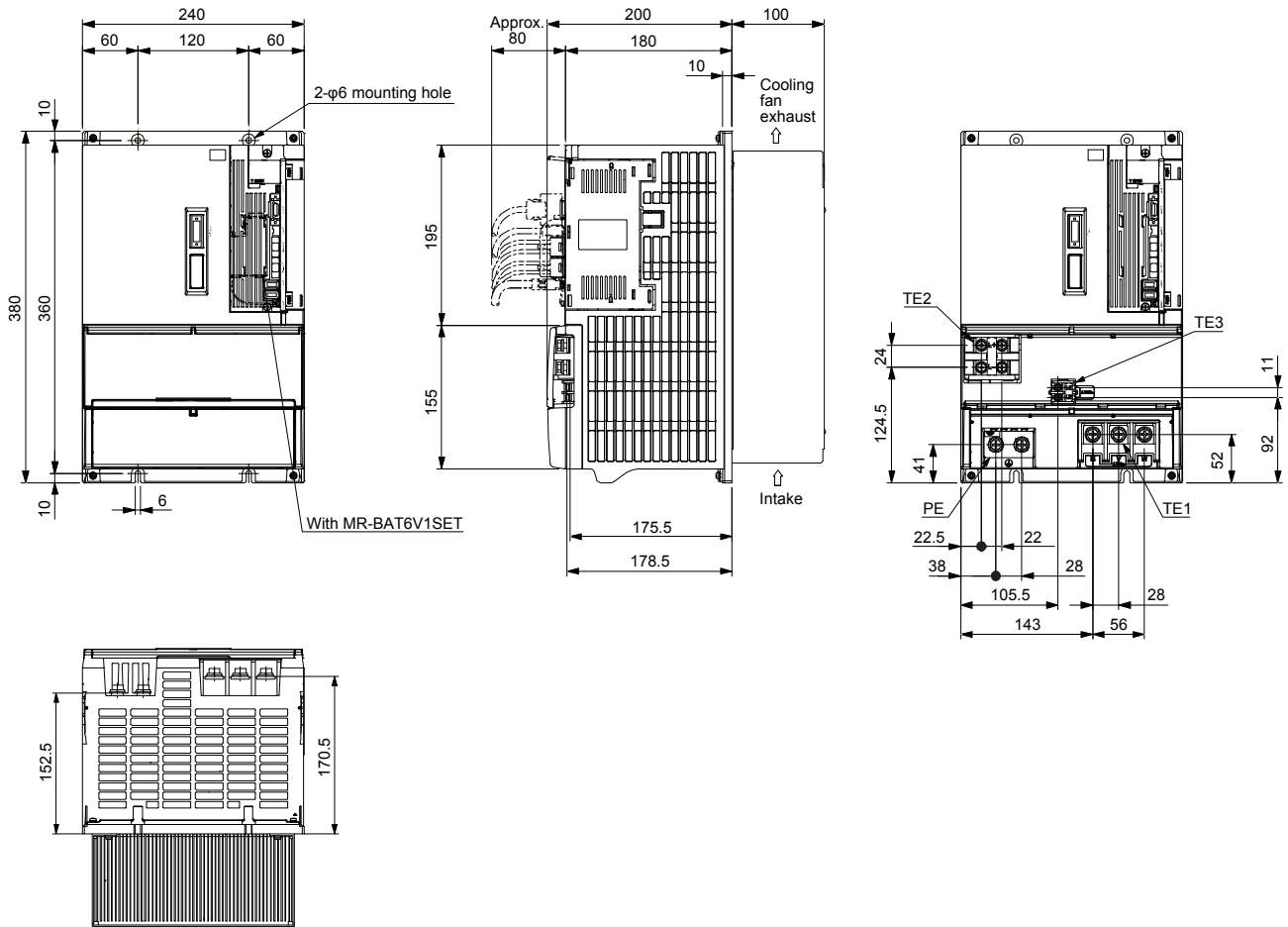

Mass: 16 [kg]
 Mounting screw
 Screw size: M5
 Tightening torque: 3.24 [N·m]

7. DIMENSIONS

7.3.2 MR-J4-DU_A_(-RJ)

POINT

● Only MR-J4-DU_A_-RJ is shown for dimensions. MR-J4-DU_A_ does not have CN2L connector. The dimensions of MR-J4-DU_A_ are the same as those of MR-J4-DU_A_-RJ except CN2L connector.

(1) MR-J4-DU30KA(-RJ)/MR-J4-DU37KA(-RJ)/MR-J4-DU45KA4(-RJ)/MR-J4-DU55KA4(-RJ)

[Unit: mm]

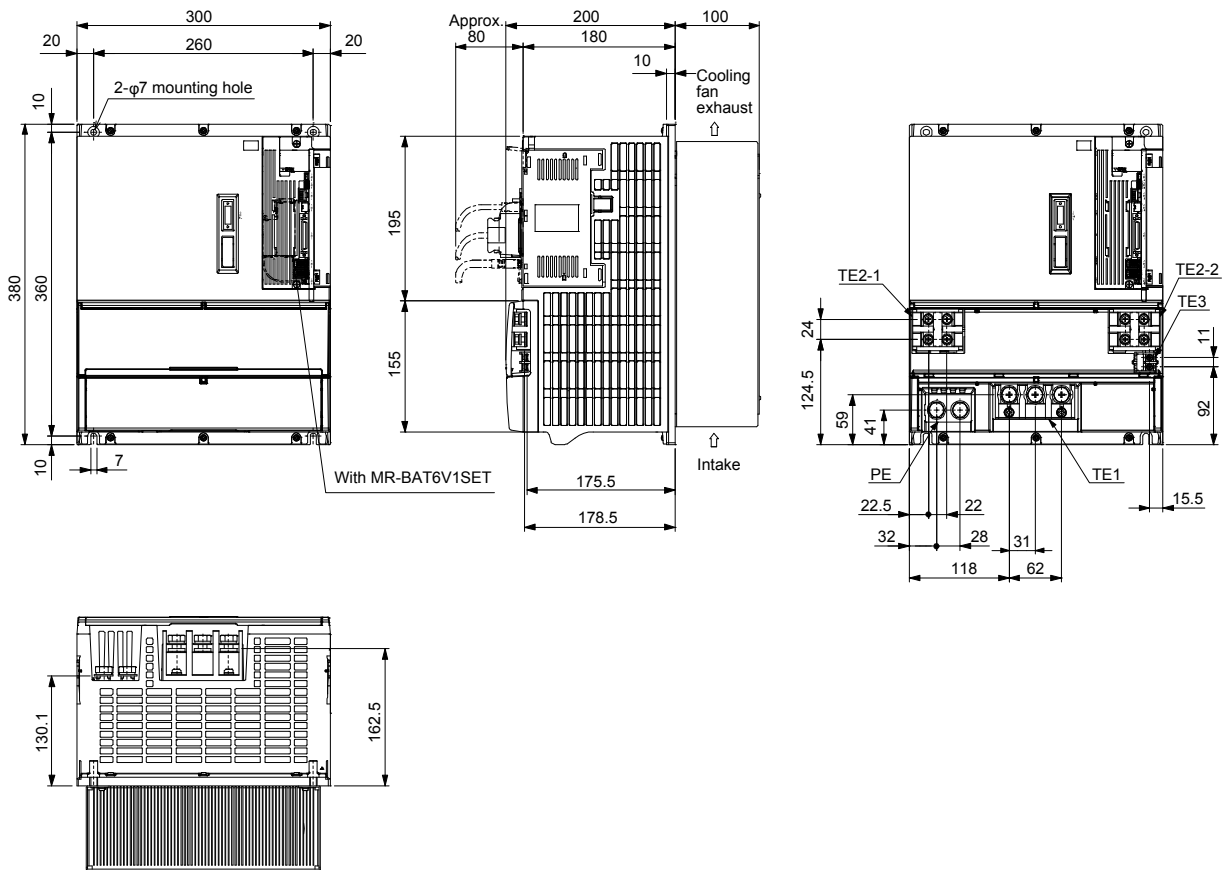

Mass: 21 [kg]

Mounting screw
Screw size: M6
Tightening torque: 5.49 [N·m]

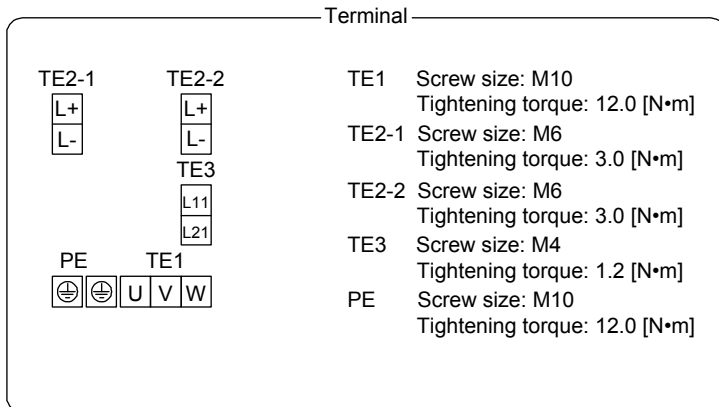

7. DIMENSIONS

(2) MR-J4-DU30KA4(-RJ)/MR-J4-DU37KA4(-RJ)

[Unit: mm]

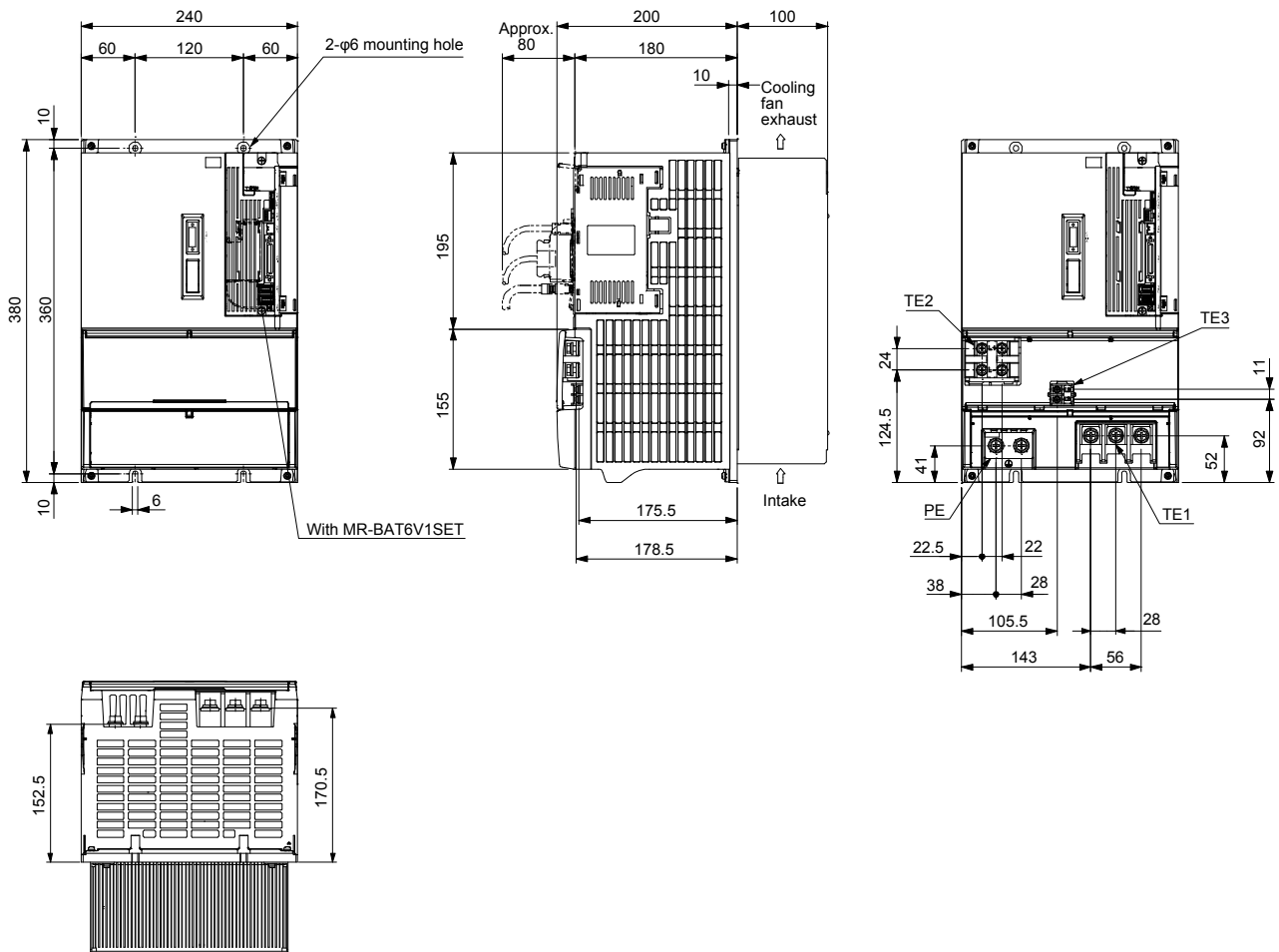

Terminal

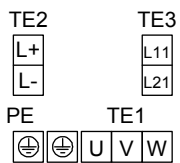

- TE1 Screw size: M8
Tightening torque: 6.0 [N•m]
- TE2 Screw size: M6
Tightening torque: 3.0 [N•m]
- TE3 Screw size: M4
Tightening torque: 1.2 [N•m]
- PE Screw size: M8
Tightening torque: 6.0 [N•m]

Mass: 16 [kg]

Mounting screw

Screw size: M5

Tightening torque: 3.24 [N•m]

8. OPTIONS AND PERIPHERAL EQUIPMENT

8. OPTIONS AND PERIPHERAL EQUIPMENT



WARNING

- Before connecting any option or peripheral equipment, turn off the power and wait for 20 minutes or more until the charge lamp turns off. Then, confirm that the voltage between L+ and L- is safe with a voltage tester and others. Otherwise, an electric shock may occur. In addition, always confirm whether the charge lamp is off or not from the front of the converter unit.



CAUTION

- Use the specified peripheral equipment and options to prevent a malfunction or a fire.

POINT

- We recommend using HIV wires to wire the converter units, drive units, options, and peripheral equipment. Therefore, the recommended wire sizes may differ from those of the used wires for the previous converter units, drive units and others.

The following items are the same as those of MR-J4-_-(-RJ). For details of the items, refer to each chapter/section of the detailed explanation field. "MR-J4-_B_" means "MR-J4-_B_-(-RJ) Servo Amplifier Instruction Manual". "MR-J4-_A_" means "MR-J4-_A_-(-RJ) Servo Amplifier Instruction Manual".

Model	Item	Detailed explanation
MR-J4-DU_B_(-RJ)	Junction terminal block PS7DW-20V14B-F (recommended)	MR-J4-_B_ section 11.6
	MR Configurator2	MR-J4-_B_ section 11.7
	Battery	MR-J4-_B_ section 11.8
	Relay (recommended)	MR-J4-_B_ section 11.13
MR-J4-DU_A_(-RJ)	Junction terminal block MR-TB50	MR-J4-_A_ section 11.6
	MR Configurator2	MR-J4-_A_ section 11.7
	Battery	MR-J4-_A_ section 11.8
	Relay (recommended)	MR-J4-_A_ section 11.13

8. OPTIONS AND PERIPHERAL EQUIPMENT

8.1 Cable/connector sets

POINT
● Refer to section 8.13 for the bus bars.

8.1.1 Combinations of cable/connector sets

Parts other than the following cable/connector sets are the same as those of MR-J4-_-(-RJ). When you use MR-J4-DU_A_(-RJ), refer to section 11.1 of "MR-J4-_A_(-RJ) Servo Amplifier Instruction Manual". When you use MR-J4-DU_B_(-RJ), refer to section 11.1 of "MR-J4-_B_(-RJ) Servo Amplifier Instruction Manual".

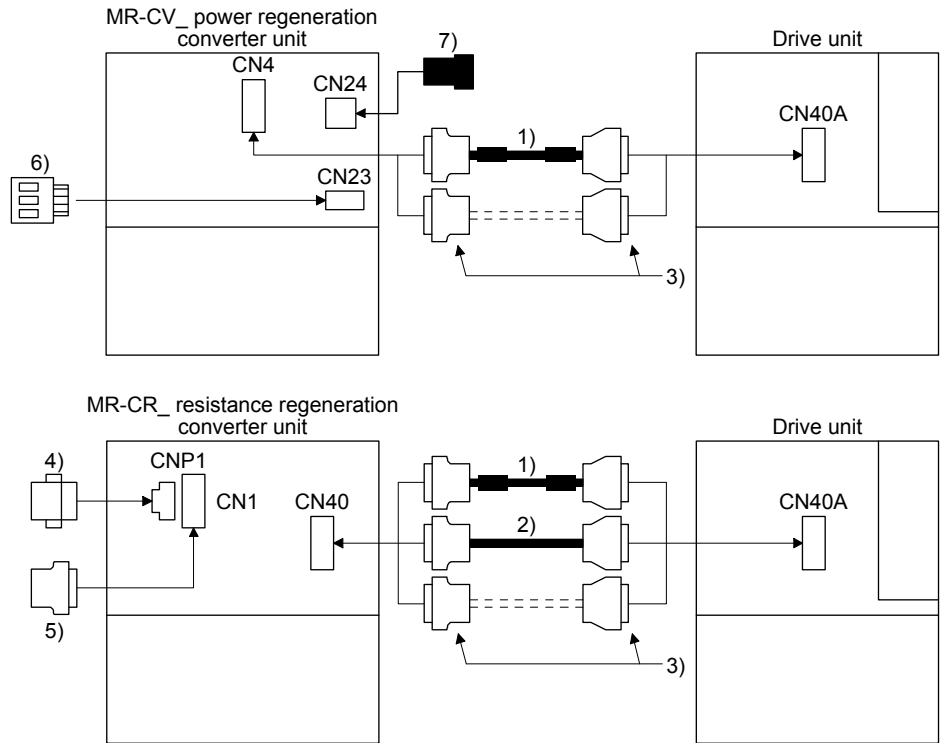

No.	Product name	Model	Description		Application
1)	Protection coordination cable	MR-CUL06M (Refer to section 9.1.2.)	Connector: 10120-3000PE Shell kit: 10320-52F0-008 (3M or equivalent)	Connector: PCR-S20FS+ Case: PCR-LS20LA1 (Honda Tsushin Kogyo)	/
2)	Protection coordination cable	MR-J3CDL05M (Refer to section 9.1.2.)	Connector: 10120-3000PE Shell kit: 10320-52F0-008 (3M or equivalent)	Connector: PCR-S20FS+ Case: PCR-LS20LA1 (Honda Tsushin Kogyo)	
3)	Connector set	MR-J2CN1-A (Refer to section 9.1.2.)	Connector: 10120-3000PE Shell kit: 10320-52F0-008 (3M or equivalent)	Connector: PCR-S20FS+ Case: PCR-LS20LA1 (Honda Tsushin Kogyo)	

8. OPTIONS AND PERIPHERAL EQUIPMENT

No.	Product name	Model	Description	Application
4)	Magnetic contactor wiring connector		MR-CR_ side connector (Phoenix Contact) Socket: GFKC 2,5/ 2-STF-7,62	Supplied with resistance regeneration converter unit
5)	Digital I/O connector		MR-CR_ side connector (DDK) Connector: 17JE23090-02(D8A)K11-CG	
6)	Magnetic contactor wiring connector		MR-CV_ side connector Connector: 03JFAT-SAXGSA-L (JST) Open tool J-FAT-OT-EXL (JST)	Supplied with power regeneration converter unit
7)	Connector set	MR-CVCN24S	MR-CV_ side connector Connector: DK-2100D-08R Contact: DK-2RECSLP1-100 (DDK) (Note)	

Note. The crimping tool (357J-22733) (DDK) is required.

8. OPTIONS AND PERIPHERAL EQUIPMENT

8.1.2 Protection coordination cable



CAUTION ● Wire protection coordination cables correctly if they are fabricated. Otherwise, it may cause an unexpected operation.

POINT

- MR-J3CDL05M is for the MR-CR_ resistance regeneration converter unit.
MR-J3CDL05M cannot be used with the MR-CV_ power regeneration converter unit.

(1) Applications of the protection coordination cable

The cable is used to connect a converter unit to a drive unit.

Protection coordination cable	Length [m]	Usable converter unit	Feature
MR-CUL06M	0.6	MR-CV_/MR-CR_	With ferrite core
MR-J3CDL05M	0.5	MR-CR_	

(2) Internal wiring diagram

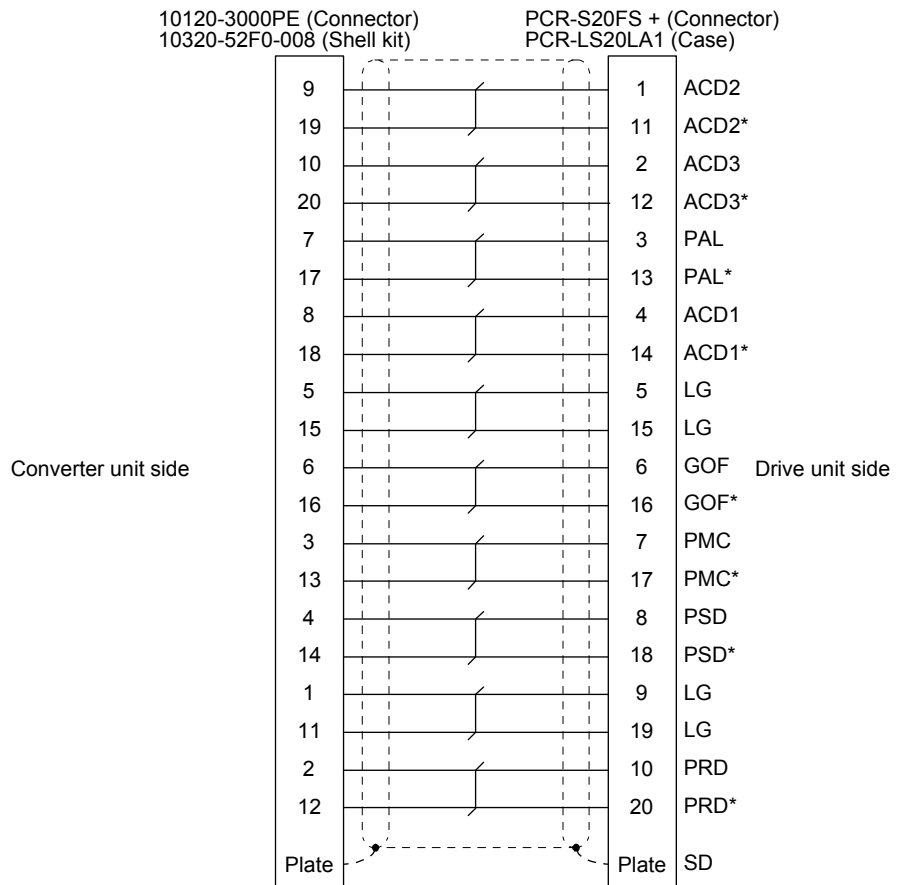

8. OPTIONS AND PERIPHERAL EQUIPMENT

(3) When fabricating a cable

Prepare MR-J2CN1-A connector set, the recommended wires, and ferrite cores (only for MR-CUL06M), and fabricate the cable according to the wiring diagram in (1) in this section.

Model	Length [m]	Core size [mm ²]	Number of cores	Characteristics of one core			(Note 2) Cable OD [mm]	Wire model	Ferrite core
				Structure [Wires/mm]	Conductor resistance [Ω/km]	(Note 1) Insulator OD d [mm]			
MR-CUL06M	0.6	0.08	20 (10 pairs)	7/0.127	222 or less	0.38	6.1	UL 20276 AWG#28 10pair (black)	ZCAT1518-0730-BK (TDK)
MR-J3CDL05M	0.5							UL 20276 AWG#28 10pair (cream)	

Note 1. The following shows the detail of d.

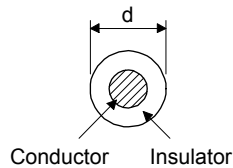

2. Standard OD. Maximum OD is about 10% greater.

When fabricating a cable equivalent to MR-CUL06M, attach the ferrite cores as follows.

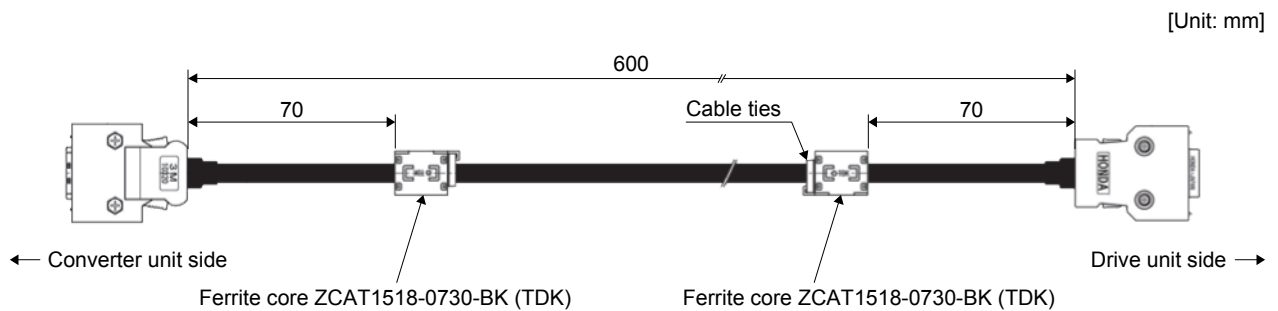

8. OPTIONS AND PERIPHERAL EQUIPMENT

8.2 Regenerative option



CAUTION

● Do not use the resistance regeneration converter unit and drive unit with the regenerative options other than the combinations specified below. Otherwise, it may cause a fire.

POINT

● MR-RB_ regenerative option is for the MR-CR_ resistance regeneration converter unit. MR-RB_ cannot be used with the MR-CV_ power regeneration converter unit.

8.2.1 Combination and regenerative power

The regenerative power values in the table are the regenerative power of the resistor and are not the rated power.

Resistance regeneration converter unit	Drive unit	Regenerative power [W]			
		MR-RB139 (1.3 Ω)	(Note 1) Three MR-RB137 (1.3 Ω) in parallel	MR-RB137-4 (4 Ω)	(Note 2) Three MR-RB13V-4 (4 Ω) in parallel
MR-CR55K	MR-J4-DU30KB(-RJ) MR-J4-DU30KA(-RJ) MR-J4-DU37KB(-RJ) MR-J4-DU37KA(-RJ)	1300	3900		
MR-CR55K4	MR-J4-DU30KB4(-RJ) MR-J4-DU30KA4(-RJ) MR-J4-DU37KB4(-RJ) MR-J4-DU37KA4(-RJ) MR-J4-DU45KB4(-RJ) MR-J4-DU45KA4(-RJ) MR-J4-DU55KB4(-RJ) MR-J4-DU55KA4(-RJ)			1300	3900

Note 1. The resultant resistance of three options is 1.3 Ω.
2. The resultant resistance of three options is 4 Ω.

8. OPTIONS AND PERIPHERAL EQUIPMENT

8.2.2 Selection of regenerative option

A regenerative option for a horizontal axis can be selected with the rough calculation shown in this section. To select a regenerative option precisely, use the capacity selection software.

(1) Rotary servo motor

(a) Regenerative energy calculation

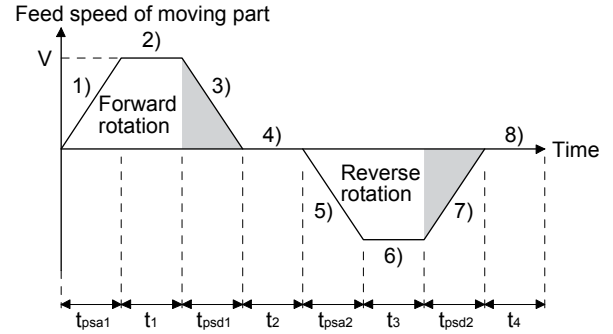
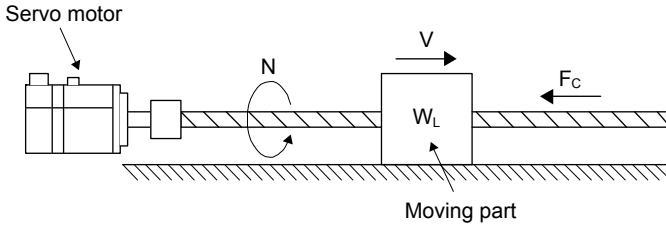

V: Feed speed of moving part	[mm/min]
N: Servo motor speed ($N = V/\Delta S$)	[r/min]
ΔS : Travel distance per servo motor revolution ($\Delta S = P_B$)	[mm/rev]
P_B : Ball screw lead	[mm]
L_B : Ball screw length	[mm]
D_B : Ball screw diameter	[mm]
W_L : Moving part mass	[kg]
F_C : Load antidrag setting	[N]
T_L : Load torque converted into equivalent value on servo motor shaft [N·m]	[N·m]
η : Drive system efficiency	
μ : Friction coefficient	
J_L : Load moment of inertia converted into equivalent value on servo motor shaft	[kg·cm ²]
J_M : Moment of inertia of the servo motor	[kg·cm ²]
π : Pi constant	
g: Gravitational acceleration	[m/s ²]

8. OPTIONS AND PERIPHERAL EQUIPMENT

Formulas for calculating torque and energy in operation

Regenerative power	Torque applied to servo motor [N·m] (Note 1, 2)	Energy E [J]
1)	$T_1 = \frac{(J_L/\eta + J_M) \cdot N}{9.55 \cdot 10^4} \cdot \frac{1}{t_{psa1}} + T_L$	$E_1 = \frac{0.1047}{2} \cdot N \cdot T_1 \cdot t_{psa1}$
2)	$T_2 = T_L$	$E_2 = 0.1047 \cdot N \cdot T_2 \cdot t_1$
3)	$T_3 = \frac{-(J_L \cdot \eta + J_M) \cdot N}{9.55 \cdot 10^4} \cdot \frac{1}{t_{psd1}} + T_L$	$E_3 = \frac{0.1047}{2} \cdot N \cdot T_3 \cdot t_{psd1}$
4), 8)	$T_4, T_8 = 0$	$E_4, E_8 = 0$ (No regeneration)
5)	$T_5 = \frac{(J_L/\eta + J_M) \cdot N}{9.55 \cdot 10^4} \cdot \frac{1}{t_{psa2}} + T_L$	$E_5 = \frac{0.1047}{2} \cdot N \cdot T_5 \cdot t_{psa2}$
6)	$T_6 = T_L$	$E_6 = 0.1047 \cdot N \cdot T_6 \cdot t_3$
7)	$T_7 = \frac{-(J_L \cdot \eta + J_M) \cdot N}{9.55 \cdot 10^4} \cdot \frac{1}{t_{psd2}} + T_L$	$E_7 = \frac{0.1047}{2} \cdot N \cdot T_7 \cdot t_{psd2}$

Note 1. Load torque converted into equivalent value on servo motor shaft T_L can be calculated with the following expression.

$$T_L = \{(F_c + (\mu \times W_L \times g)) \times \Delta S\} / (2000 \times \pi \times \eta)$$

2. Load moment of inertia converted into equivalent value on servo motor shaft J_L can be calculated with the following expression.

$$J_L = J_{L1} + J_{L2} + J_{L3}$$

J_{L1} is the load moment of inertia of the moving part, J_{L2} is the load moment of inertia of the ball screw, and J_{L3} is the load moment of inertia of the coupling. J_{L1} and J_{L2} can be calculated with the following expressions.

$$J_{L1} = W_L \times (\Delta S / (20 \times \pi))^2$$

$$J_{L2} = \{(\pi \times 0.0078 \times (L_B/10)) / 32\} \times (D_B/10)^4$$

From the calculation results in 1) to 8), find the absolute value (E_s) of the sum total of negative energies.

8. OPTIONS AND PERIPHERAL EQUIPMENT

(2) Regenerative loss of servo motor and drive unit

The following table lists the efficiencies and other data of the servo motor and drive unit in the regenerative mode.

Resistance regeneration converter unit	Drive unit	Inverse efficiency [%]	Capacitor charging [J]
MR-CR55K	MR-J4-DU30KB(-RJ) MR-J4-DU30KA(-RJ) MR-J4-DU37KB(-RJ) MR-J4-DU37KA(-RJ)	90	450
MR-CR55K4	MR-J4-DU30KB4(-RJ) MR-J4-DU30KA4(-RJ) MR-J4-DU37KB4(-RJ) MR-J4-DU37KA4(-RJ) MR-J4-DU45KB4(-RJ) MR-J4-DU45KA4(-RJ) MR-J4-DU55KB4(-RJ) MR-J4-DU55KA4(-RJ)		

Inverse efficiency (η_m): Efficiency including some efficiencies of the servo motor and drive unit when rated (regenerative) torque is generated at rated speed. Efficiency varies with the speed and generated torque. Since the characteristics of the electrolytic capacitor change with time, allow for approximately 10% higher inverse efficiency.

Capacitor charging (E_c): Energy charged into the electrolytic capacitor in the resistance regeneration converter unit

Subtract the capacitor charging from the result of multiplying the sum total of regenerative energies by the inverse efficiency to calculate the energy consumed by the regenerative option.

$$ER [J] = \eta_m \cdot E_s - E_c$$

Calculate the power consumption of the regenerative option on the basis of one-cycle operation period t_f [s] to select the necessary regenerative option.

$$PR [W] = ER/t_f$$

8.2.3 Parameter setting

POINT
<p>● The regenerative option cannot be connected to the drive unit. Always set [Pr. PA02] of the drive unit to "_ _ 0 0" (the regenerative option is not used).</p>

Set [Pr. PA01] of the resistance regeneration converter unit according to the option to be used.

[Pr. PA01]			
0	0		

Regenerative option selection
 00: Regenerative option is not used.
 01: MR-RB139
 02: MR-RB137 (3 pcs.)
 13: MR-RB137-4
 14: MR-RB13V-4 (3 pcs.)

8. OPTIONS AND PERIPHERAL EQUIPMENT

8.2.4 Connection of regenerative option

POINT
● For the wire sizes used for wiring, refer to section 8.4.

The regenerative option generates heat of 100 °C higher than the ambient temperature. Fully consider heat dissipation, installation position, wires used, etc. before installing the option. For wiring, use flame-resistant wires or make the wires flame-resistant and keep them away from the regenerative option. The G3 and G4 terminals act as a thermal protector. Between G3 and G4 is opened when the regenerative option overheats abnormally.

Always use twisted cables of max. 5 m length for connection with the resistance regeneration converter unit.

(1) Cooling fan

Always supply the following power to a cooling fan.

Item	200 V class	400 V class
Model	MR-RB137/MR-RB139	MR-RB137-4/MR-RB13V-4
Voltage/Frequency	1-phase 198 V AC to 242 V AC, 50 Hz/60 Hz	1-phase 380 V AC to 480 V AC, 50 Hz/60 Hz
Power consumption [W]	20 (50 Hz)/18 (60 Hz)	20 (50 Hz)/18 (60 Hz)

(2) MR-RB139/MR-RB137-4

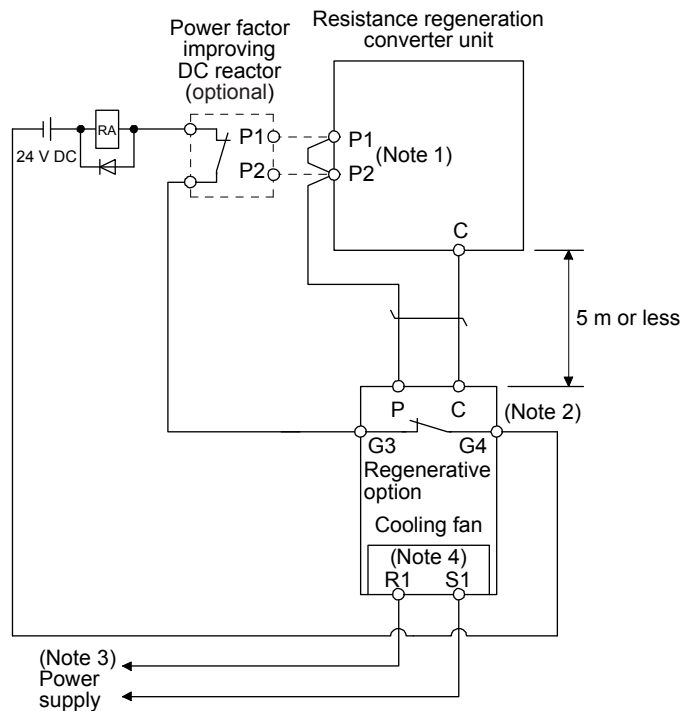

- Note 1. When using the power factor improving DC reactor, remove the short bar across P1 and P2.
- Note 2. G3-G4 contact specifications
 Maximum voltage: 120 V AC/DC
 Maximum current: 0.5 A/4.8 V DC
 Maximum capacity: 2.4 VA
- Note 3. For specifications of cooling fan power supply, refer to (1) in this section.
- Note 4. For MR-RB137-4, "R1" is "R400" and "S1" is "S400".

8. OPTIONS AND PERIPHERAL EQUIPMENT

(3) MR-RB137/MR-RB13V-4

POINT
<p>● Three of MR-RB137 or MR-RB13V-4 are required per resistance regeneration converter unit. Please purchase three of MR-RB137 or MR-RB13V-4.</p>

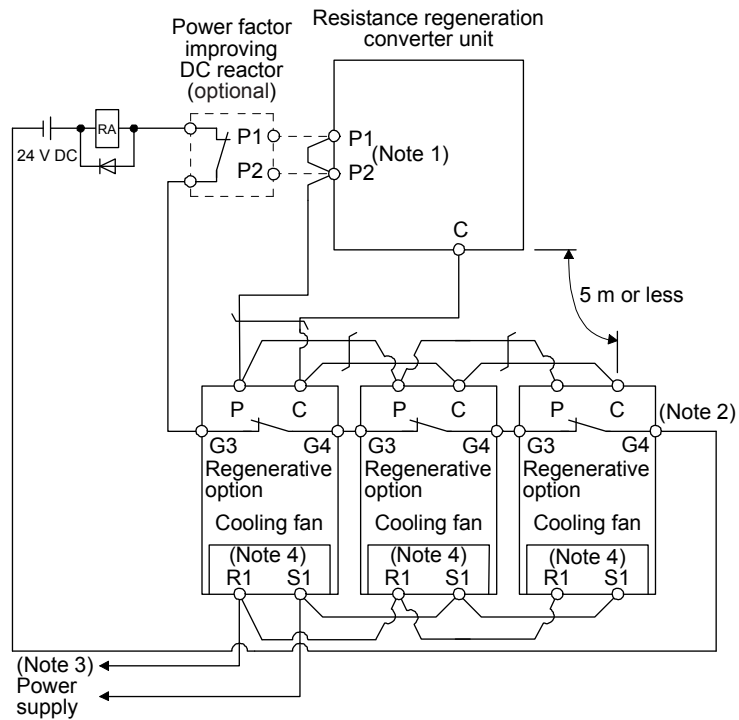

- Note 1. When using the power factor improving DC reactor, remove the short bar across P1 and P2.
- Note 2. G3-G4 contact specifications
 Maximum voltage: 120 V AC/DC
 Maximum current: 0.5 A/4.8 V DC
 Maximum capacity: 2.4 VA
- Note 3. For specifications of cooling fan power supply, refer to (1) in this section.
- Note 4. For MR-RB13V-4, "R1" is "R400" and "S1" is "S400".

8. OPTIONS AND PERIPHERAL EQUIPMENT

8.2.5 Dimensions

[Unit: mm]

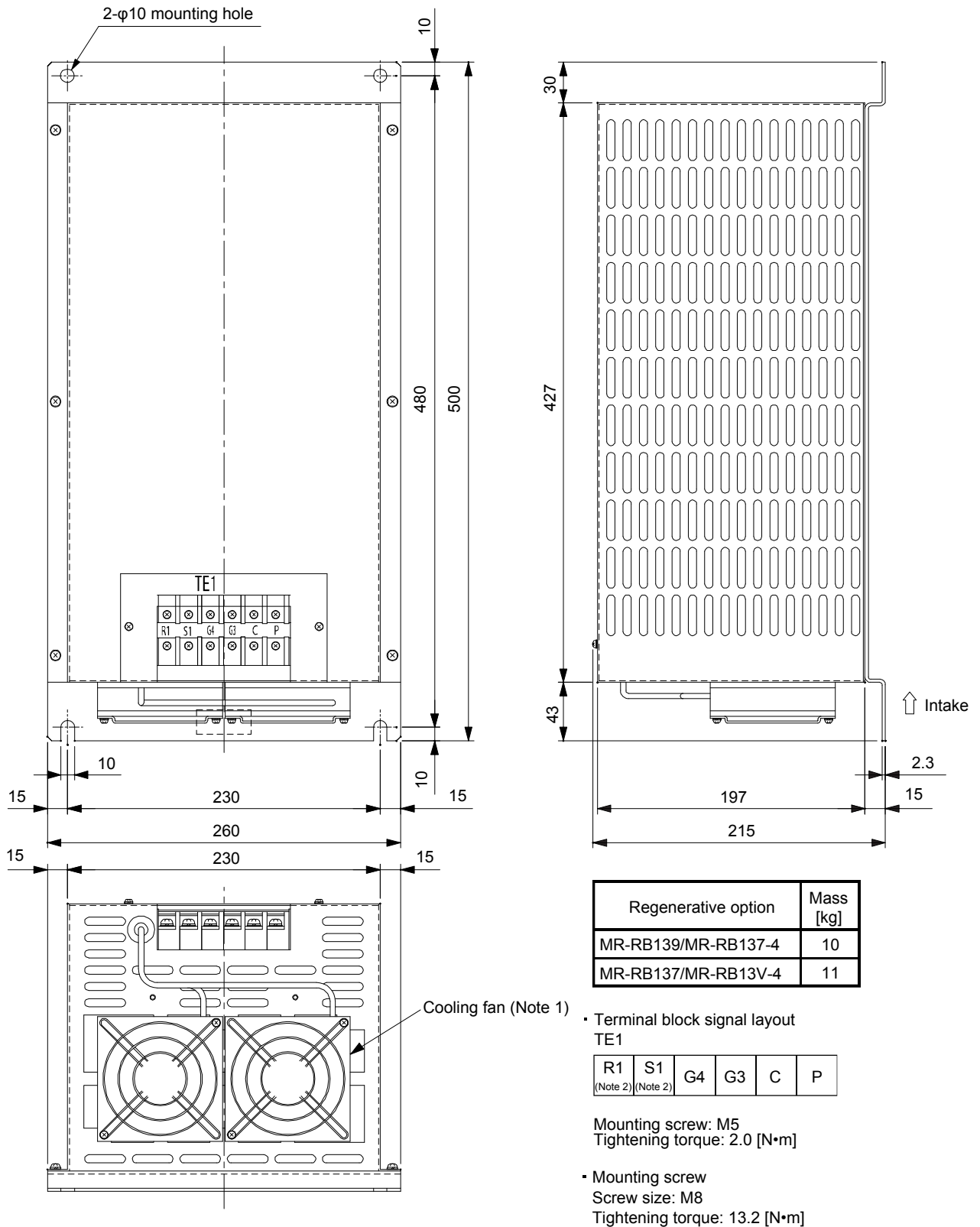

- Note 1. One cooling fan for MR-RB137-4/MR-RB13V-4.
 2. For MR-RB137-4/MR-RB13V-4, "R1" is "R400" and "S1" is "S400".

8. OPTIONS AND PERIPHERAL EQUIPMENT

8.3 External dynamic brake

CAUTION

- Use an external dynamic brake for this drive unit. Failure to do so will cause an accident because the servo motor does not stop immediately but coasts at an alarm occurrence for which the servo motor does not decelerate to stop. Ensure the safety in the entire equipment. For alarms for which the servo motor does not decelerate to stop, refer to chapter 6.
- The external dynamic brake cannot be used for compliance with SEMI-F47 standard. Do not assign DB. Doing so will cause the drive unit to become servo-off when an instantaneous power failure occurs.

POINT

- For drive units, EM2 has the same function as EM1 in the torque control mode.
- Configure a sequence which switches off the magnetic contactor of the external dynamic brake after (or as soon as) SON (Servo-on) has been turned off at a power failure or a malfunction.
- For the external braking time taken when the dynamic brake is operated, refer to section 5.4.2.
- The external dynamic brake is rated for a short duration. Do not use it very frequently.
- When the 400 V class external dynamic brake is used, the power supply voltage is restricted to 1-phase 380 V AC to 463 V AC (50 Hz/60 Hz).
- The specifications of the input power supply for external dynamic brake used for drive units of 30 kW or more are the same as those of the converter unit control circuit power supply.
- When an alarm, [AL. E6 Servo forced stop warning], or [AL. E7 Controller forced stop warning] occurs, or the power is turned off, the external dynamic brake will operate. Do not use external dynamic brake to stop in a normal operation as it is the function to stop in emergency.
- For a machine operating at the recommended load to motor inertia ratio or less, the estimated number of usage times of the external dynamic brake is 1000 times while the machine decelerates from the rated speed to a stop once in 10 minutes.
- Be sure to enable EM1 (Forced stop 1) after servo motor stops when using EM1 frequently in other than emergency.

8. OPTIONS AND PERIPHERAL EQUIPMENT

8.3.1 Selection of external dynamic brake

The external dynamic brake is designed to bring the servo motor to a sudden stop when a power failure occurs or the protective circuit is activated. For MR-J4-DU_A_(-RJ) drive unit, assign DB to any of CN1-22 to CN1-25, CN1-49, CN1-13 and CN1-14 pins in [Pr. PD23] to [Pr. PD26], [Pr. PD28] and [Pr. PD47]. For MR-J4-DU_B_(-RJ) drive unit, assign DB to any of CN3-9, CN3-13, and CN3-15 pins in [Pr. PD07] to [Pr. PD09].

Drive unit	External dynamic brake	Molded-case circuit breaker		Fuse (Class T)		Fuse (Class K5)	
		Frame, rated current	Voltage AC [V]	Current [A]	Voltage AC [V]	Current [A]	Voltage AC [V]
MR-J4-DU900B(-RJ)	DBU-7K-R6 DBU-11K (Note 1)	30 A frame 5 A	240	1	300	1	250
MR-J4-DU11KB(-RJ)	DBU-11K						
MR-J4-DU15KB(-RJ)	DBU-15K						
MR-J4-DU22KB(-RJ)	DBU-22K-R1						
MR-J4-DU30KB(-RJ)	DBU-37K-R1						
MR-J4-DU30KA(-RJ)							
MR-J4-DU37KB(-RJ)							
MR-J4-DU37KA(-RJ)							
MR-J4-DU900B4(-RJ)	DBU-7K-4-2R0 DBU-11K-4 (Note 2)	30 A frame 5 A	480	1	600	1	600
MR-J4-DU11KB4(-RJ)	DBU-11K-4						
MR-J4-DU15KB4(-RJ)	DBU-22K-4						
MR-J4-DU22KB4(-RJ)							
MR-J4-DU30KB4(-RJ)	DBU-55K-4-R5						
MR-J4-DU30KA4(-RJ)							
MR-J4-DU37KB4(-RJ)							
MR-J4-DU37KA4(-RJ)							
MR-J4-DU45KB4(-RJ)							
MR-J4-DU45KA4(-RJ)							
MR-J4-DU55KB4(-RJ)							
MR-J4-DU55KA4(-RJ)							

- Note 1. When HG-JR801 or HG-JR903 is used.
 2. When HG-JR8014 or HG-JR9034 is used.

8.3.2 Connection example

(1) For MR-CV_ power regeneration converter unit

Use the following wires to connect the dynamic brake.

External dynamic brake	Wire [mm ²] (Note)	
	U/V/W	Except U/V/W
DBU-7K-R6	3.5 (AWG 12)	2 (AWG 14)
DBU-11K DBU-15K DBU-22K-R1	5.5 (AWG 10)	
DBU-37K-R1	14 (AWG 6)	
DBU-7K-4-2R0	3.5 (AWG 12)	
DBU-11K-4 DBU-22K-4	5.5 (AWG 10)	
DBU-55K-4-R5	14 (AWG 6)	

- Note. Selection conditions of wire size are as follows.
 Wire type: 600 V grade heat-resistant polyvinyl chloride insulated wire (HIV wire)
 Construction condition: Single wire set in midair

8. OPTIONS AND PERIPHERAL EQUIPMENT

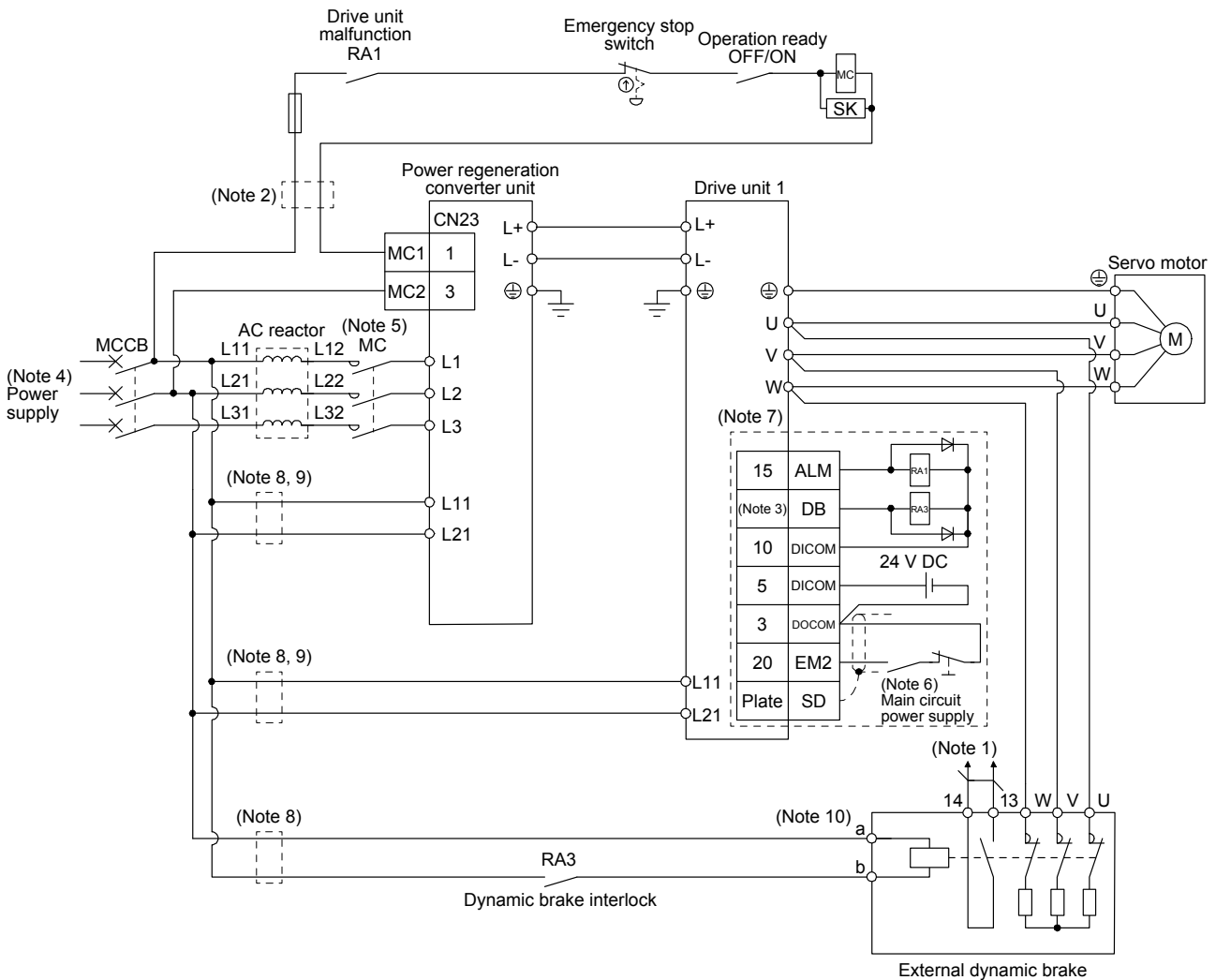

- Note 1. Terminals 13 and 14 are normally open contact outputs. If the dynamic brake is seized, terminals 13 and 14 will open. Therefore, configure an external sequence to prevent servo-on.
- Note 2. Step-down transformer is required when coil voltage of the magnetic contactor is 200 V class, and the power regeneration converter unit and the drive unit are 400 V class.
- Note 3. Assign DB (Dynamic brake interlock) with the parameter.
- Note 4. For the power supply specifications, refer to section 1.4.
- Note 5. A bus voltage may drop, depending on the main circuit voltage and operation pattern, causing a dynamic brake deceleration during a forced stop deceleration. When dynamic brake deceleration is not required, delay the time to turn off the magnetic contactor.
- Note 6. Turn off EM2 when the main power circuit power supply is off.
- Note 7. The wiring is for MR-J4-DU_B_(-RJ).
- Note 8. Install an overcurrent protection device (molded-case circuit breaker, fuse, or others) to protect the branch circuit. (Refer to section 8.5 and section 8.3.1.)
- Note 9. The control circuit power supply (L11/L21) can be connected by passing wiring. Refer to section 6.8 for the wire size and the selection of the overcurrent protection device.
- Note 10. The power supply voltage of the inside magnet contactor for 400 V class external dynamic brake DBU-7K-4-2R0, DBU-11K-4, and DBU-22K-4 is restricted to 1-phase 380 V AC to 463 V AC (50 Hz/60 Hz). When these external dynamic brakes are used, use them within the range of the power supply.

8. OPTIONS AND PERIPHERAL EQUIPMENT

(2) MR-CR_ resistance regeneration converter unit

Use the following wires to connect the dynamic brake.

Dynamic brake	Wire [mm ²] (Note)	
	Except U/V/W	U/V/W
DBU-37K-R1	14 (AWG 6)	2 (AWG 14)
DBU-55K-4-R5		

Note. Selection conditions of wire size are as follows.

Wire type: 600 V grade heat-resistant polyvinyl chloride insulated wire (HIV wire)

Construction condition: Single wire set in midair

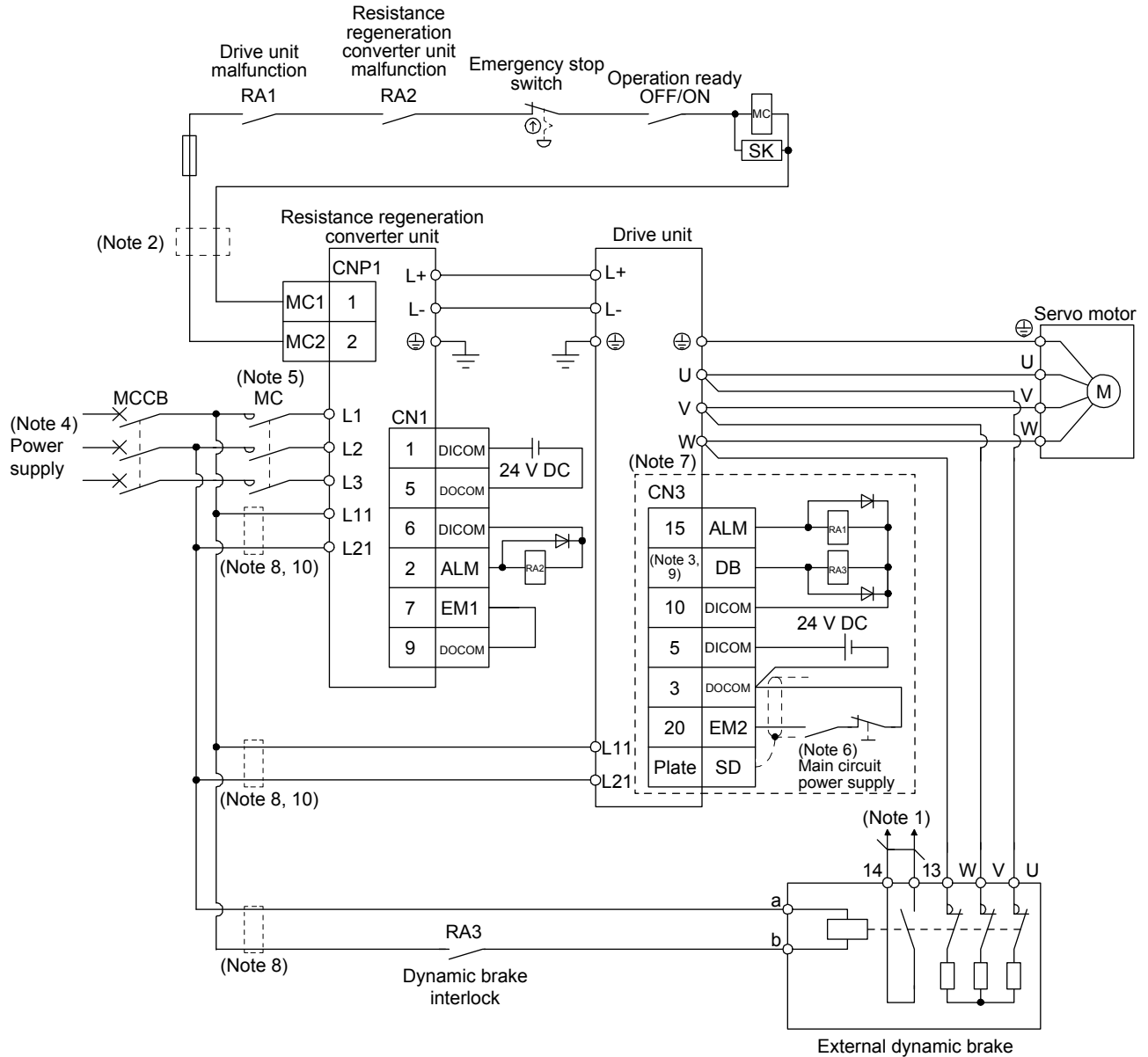

8. OPTIONS AND PERIPHERAL EQUIPMENT

- Note
1. Terminals 13 and 14 are normally open contact outputs. If the dynamic brake is seized, terminals 13 and 14 will open. Therefore, configure an external sequence to prevent servo-on.
 2. Step-down transformer is required when coil voltage of the magnetic contactor is 200 V class, and the resistance regeneration converter unit and the drive unit are 400 V class.
 3. Assign DB (Dynamic brake interlock) with the parameter.
 4. For the power supply specifications, refer to section 1.4.
 5. Depending on the main circuit voltage and operation pattern, bus voltage decreases, and that may cause the forced stop deceleration to shift to the dynamic brake deceleration. When dynamic brake deceleration is not required, slow the time to turn off the magnetic contactor.
 6. Turn off EM2 when the main power circuit power supply is off.
 7. The wiring is for MR-J4-DU_B_(-RJ). The connection for the interface of MR-J4-DU_(-RJ) is the same as in the case of MR-J4_(-RJ). Refer to each servo amplifier instruction manual.
 8. Install an overcurrent protection device (molded-case circuit breaker or fuse) to protect the branch circuit. (Refer to section 8.5 and section 8.3.1.)
 9. The external dynamic brake cannot be used for compliance with SEMI-F47 standard. Do not assign DB. Doing so will cause the drive unit to become servo-off when an instantaneous power failure occurs.
 10. The control circuit power supply (L11/L21) can be connected by passing wiring. Refer to section 6.8 for the wire size and the selection of the overcurrent protection device.

8. OPTIONS AND PERIPHERAL EQUIPMENT

8.3.3 Timing chart

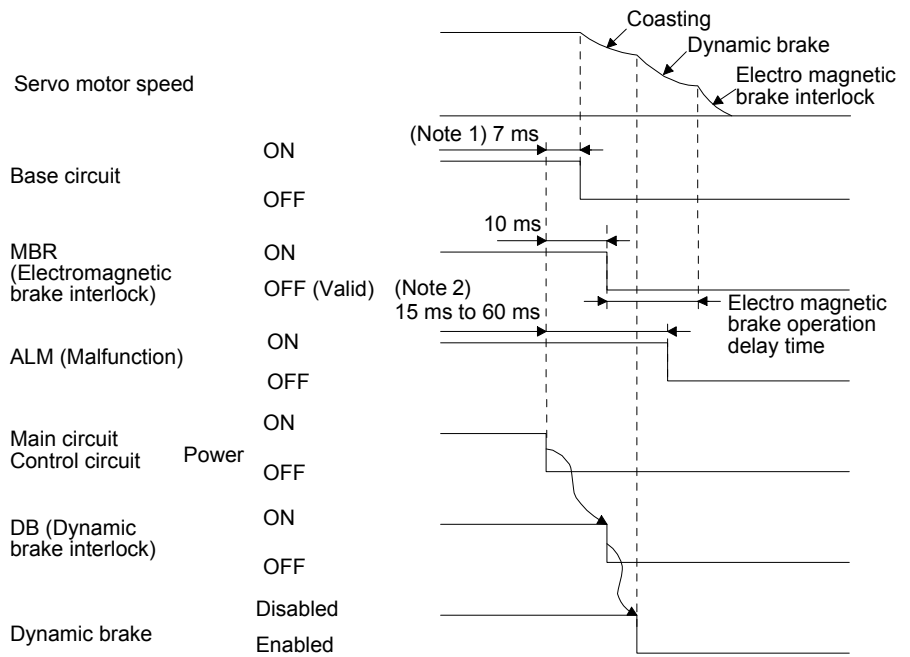
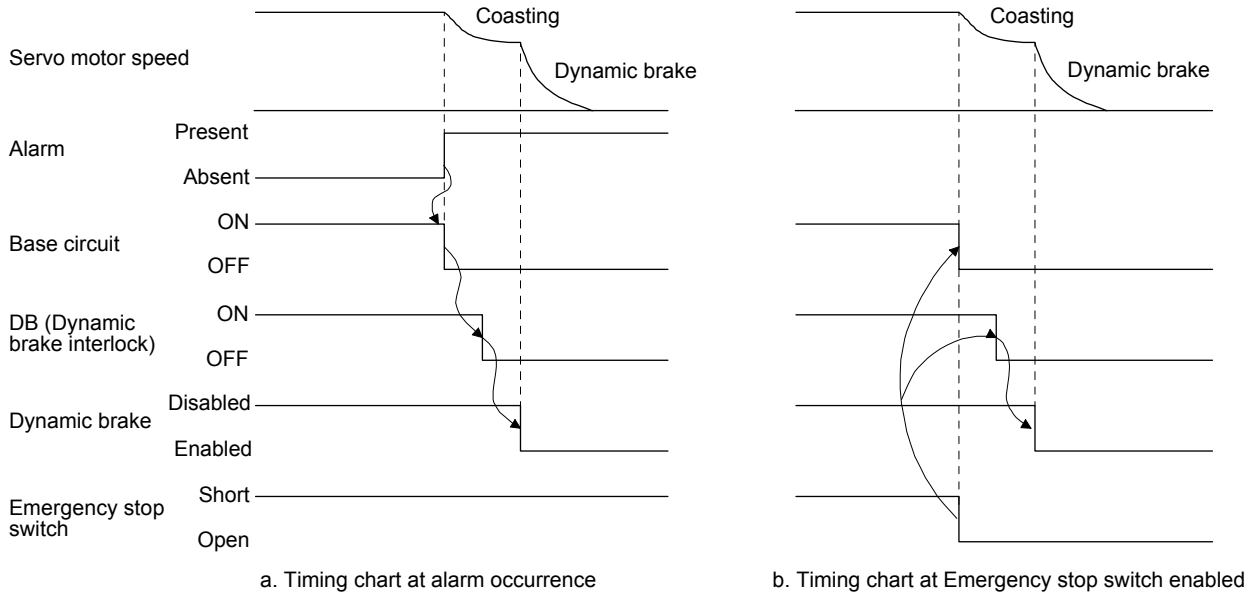

- Note 1. When powering off, DB will be turned off, and the base circuit is turned off earlier than usual before an output shortage occurs.
(only when DB is assigned as an output signal)
- Note 2. Variable according to the operation status.

c. Timing chart when both of the main and control circuit power supply are off

8. OPTIONS AND PERIPHERAL EQUIPMENT

8.3.4 Dimensions

(1) DBU-7K-R6/DBU-11K/DBU-15K/DBU-22K-R1

[Unit: mm]

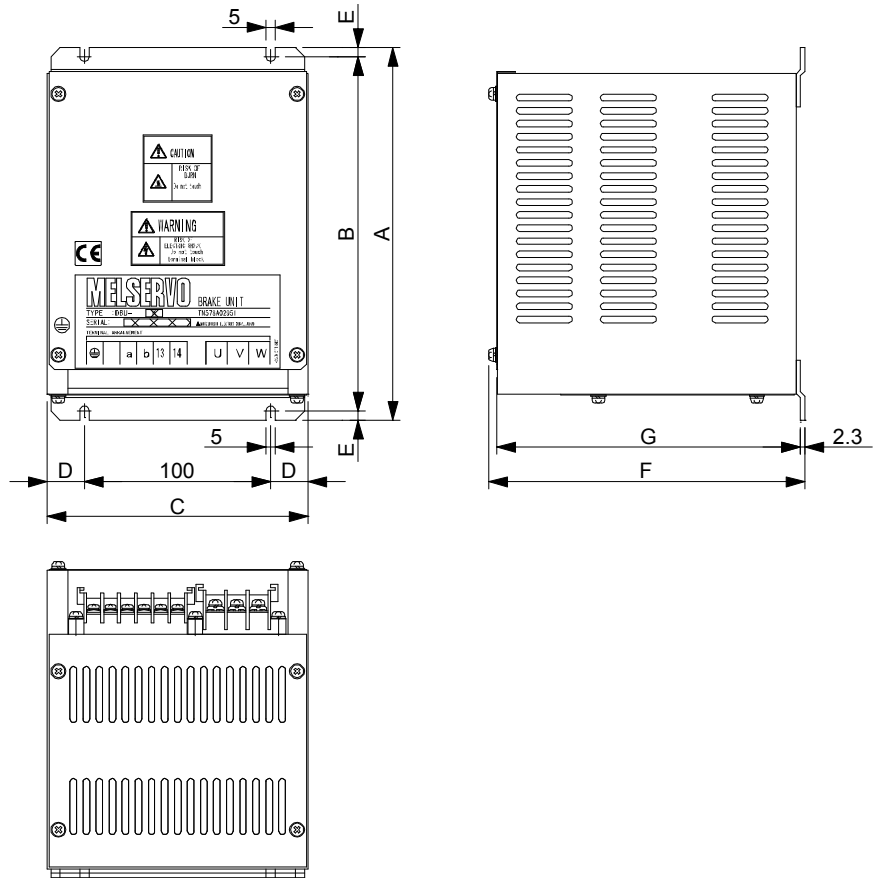

Terminal block

TE1

⊕	/	a	b	13	14
---	---	---	---	----	----

Screw: M3.5

Tightening torque: 0.8 [N•m]

TE2

U	V	W
---	---	---

Screw: M4

Tightening torque: 1.2 [N•m]

External dynamic brake	A	B	C	D	E	F	G	Mass [kg]
DBU-7K-R6 DBU-11K	200	190	140	20	5	170	163.5	2
DBU-15K DBU-22K-R1	250	238	150	25	6	235	228	6

8. OPTIONS AND PERIPHERAL EQUIPMENT

(2) DBU-7K-4-2R0/DBU-11K-4/DBU-22K-4

[Unit: mm]

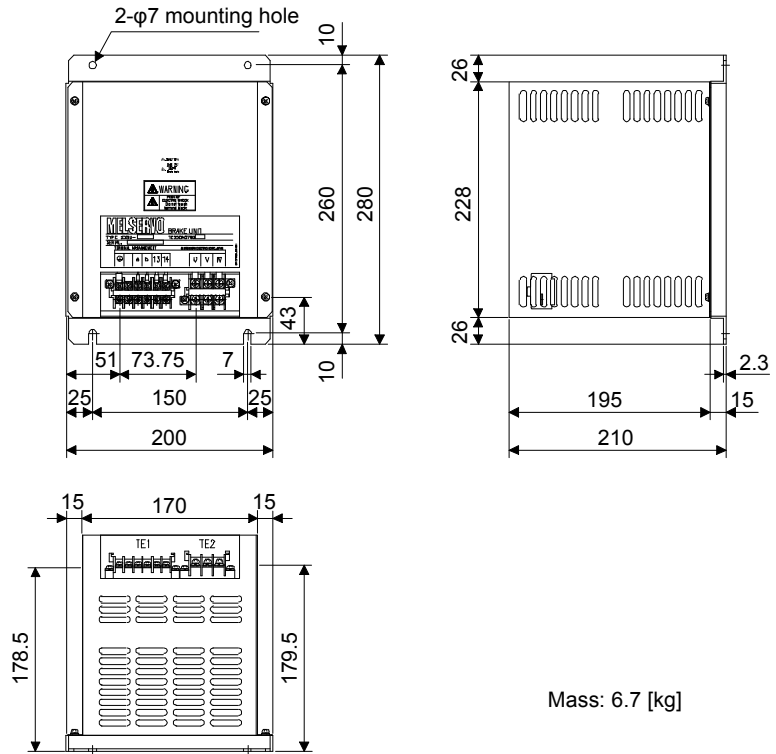

Mass: 6.7 [kg]

Terminal block

TE1

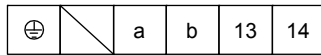

Screw: M3.5

Tightening torque: 0.8 [N•m]

TE2

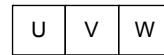

Screw: M4

Tightening torque: 1.2 [N•m]

8. OPTIONS AND PERIPHERAL EQUIPMENT

(3) DBU-37K-R1/DBU-55K-4-R5

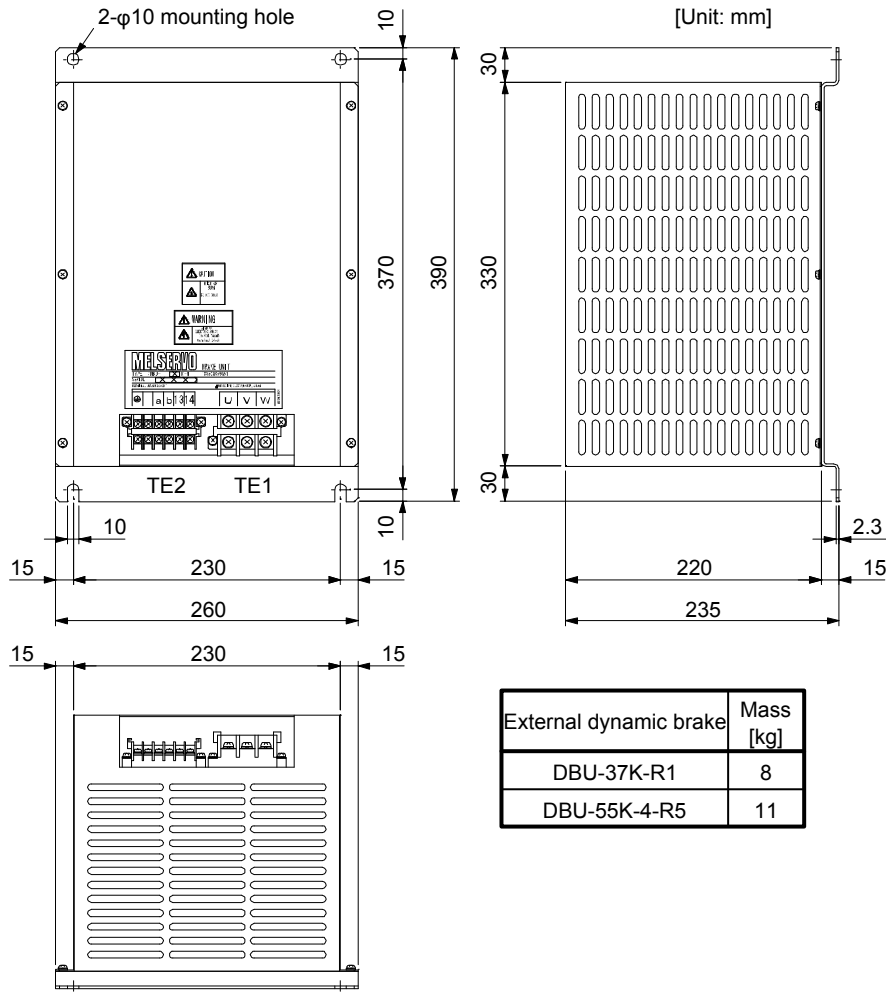

8. OPTIONS AND PERIPHERAL EQUIPMENT

8.4 Selection example of wires

POINT
<ul style="list-style-type: none"> ● To comply with the IEC/EN/UL/CSA standard, use the wires shown in section 10.2 for wiring. To comply with other standards, use a wire that is complied with each standard. ● Selection conditions of wire size are as follows. Construction condition: Single wire set in midair Wire length: 50 m or less

8.4.1 Connection of converter unit and drive unit

The following diagram shows the wires used for wiring. Use the wires given in this section or equivalent.

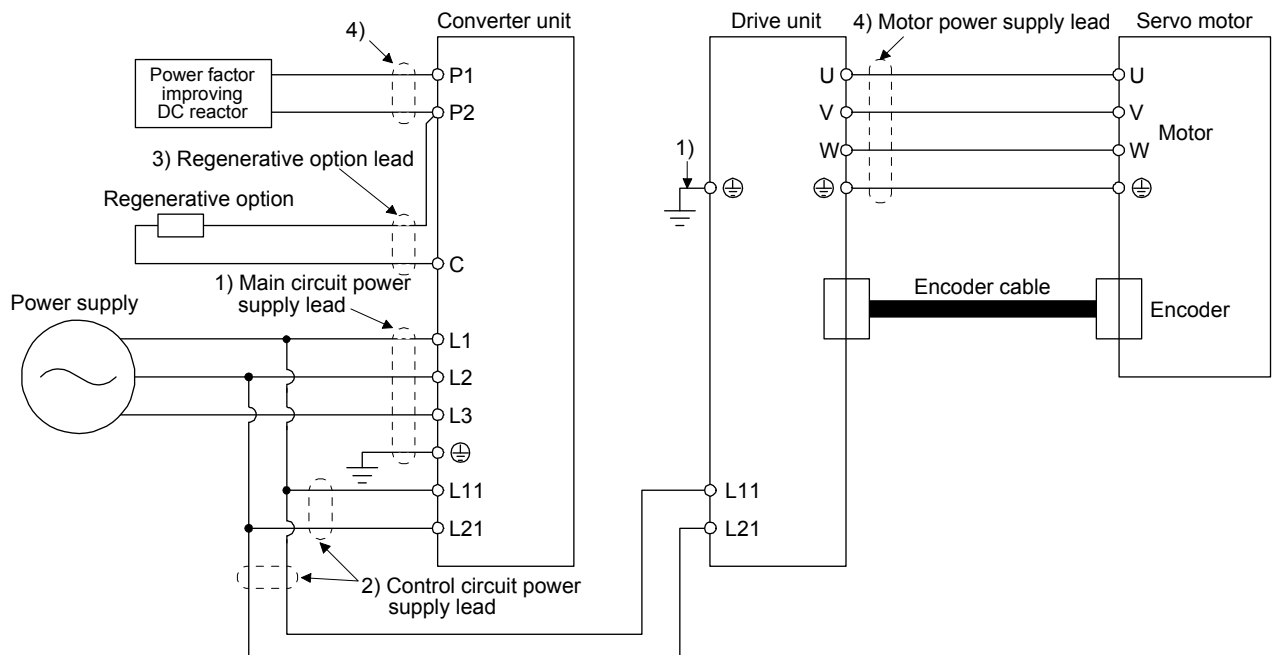

8. OPTIONS AND PERIPHERAL EQUIPMENT

(1) Example of selecting the wire sizes

Use the 600 V grade heat-resistant polyvinyl chloride insulated wire (HIV wire) for wiring. The following shows the wire size selection example.

Converter unit (Note 2)	Drive unit (Note 2)	Wire [mm ²] (Note 1, 3)				
		1) L1/L2/L3/⊕	2) L11/L21	3) P2/C	4) P1/P2 ⊕	
MR-CV11K		8 (AWG 8): h	1.25 to 2 (AWG 16 to 14): g (Note 4)			
MR-CV18K		22 (AWG 4): q				
MR-CV30K		38 (AWG 2): n				
MR-CV37K		60 (AWG 2/0): j				
MR-CV45K		60 (AWG 2/0): j				
MR-CV55K		80 (AWG 3/0): k				
MR-CV11K4		5.5 (AWG 10): l				
MR-CV18K4		8 (AWG 8): h				
MR-CV30K4		14 (AWG 6): m				
MR-CV37K4		22 (AWG 4): e				
MR-CV45K4		22 (AWG 4): e				
MR-CV55K4		38 (AWG 2): n				
MR-CV75K4		60 (AWG 2/0): j				
MR-CR55K		MR-J4-DU30K_(-RJ)				38 (AWG 2): c
	MR-J4-DU37K_(-RJ)	60 (AWG 2/0): d	60 (AWG 2/0): d			
MR-CR55K4	MR-J4-DU30K_4(-RJ)	22 (AWG 4): b		22(AWG 4): b		
	MR-J4-DU37K_4(-RJ)	22 (AWG 4): b		38 (AWG 2): c		
	MR-J4-DU45K_4(-RJ)	38 (AWG 2): c		38 (AWG 2): c		
	MR-J4-DU55K_4(-RJ)	38 (AWG 2): c		38 (AWG 2): c		

- Note
1. Alphabets in the table indicate crimping tools. For crimp terminals and applicable tools, refer to (2) in this section.
 2. To connect these models to a terminal block, be sure to use the screws that come with the terminal block.
 3. Wires are selected based on the highest rated current among combining servo motors.
 4. Be sure to use the size of 2 mm² when corresponding to the IEC/EN/UL/CSA standard.

8. OPTIONS AND PERIPHERAL EQUIPMENT

Drive unit (Note 2)	Wire [mm ²] (Note 1, 3)	
	5) U/V/W/⊕	2) L11/L21
MR-J4-DU900B(-RJ)	14 (AWG 6): m	1.25 to 2 (AWG 16 to 14): g (Note 4)
MR-J4-DU11KB(-RJ)	14 (AWG 6): m	
MR-J4-DU15KB(-RJ)	22 (AWG 4): e	
MR-J4-DU22KB(-RJ)	38 (AWG 2): n	
MR-J4-DU30KB(-RJ)	60 (AWG 2/0): d	
MR-J4-DU30KA(-RJ)		
MR-J4-DU37KB(-RJ)	60 (AWG 2/0): d	
MR-J4-DU37KA(-RJ)		
MR-J4-DU900B4(-RJ)	8 (AWG 8): o	
MR-J4-DU11KB4(-RJ)	8 (AWG 8): o	
MR-J4-DU15KB4(-RJ)	8 (AWG 8): o	
MR-J4-DU22KB4(-RJ)	14 (AWG 6): m	
MR-J4-DU30KB4(-RJ)	22 (AWG 4): e	
MR-J4-DU30KA4(-RJ)		
MR-J4-DU37KB4(-RJ)	22 (AWG 4): e	
MR-J4-DU37KA4(-RJ)		
MR-J4-DU45KB4(-RJ)	38 (AWG 2): c	
MR-J4-DU45KA4(-RJ)		
MR-J4-DU55KB4(-RJ)	38 (AWG 2): c	
MR-J4-DU55KA4(-RJ)		

- Note
1. Alphabets in the table indicate crimping tools. For crimp terminals and applicable tools, refer to in this section.
 2. To connect these models to a terminal block, be sure to use the screws that come with the terminal block.
 3. Wires are selected based on the highest rated current among combining servo motors.
 4. Be sure to use the size of 2 mm² when corresponding to the IEC/EN/UL/CSA standard.

8. OPTIONS AND PERIPHERAL EQUIPMENT

(2) Selection example of crimp terminals

The following shows the selection example of crimp terminals for terminal blocks of the drive unit and converter unit when you use wires mentioned in (1) in this section.

Symbol	Drive unit/converter unit-side crimp terminal				Manufacturer
	Crimp terminal (Note 2)	Applicable tool			
		Body	Head	Dice	
a	FVD5.5-10	YNT-1210S			JST
b	FVD22-10	YF-1 E-4	YNE-38	DH-123 DH-113	
c (Note 1)	R38-10	YPT-60-21		TD-124	
		YF-1 E-4	YET-60-1	TD-112	
d (Note 1)	R60-10	YPT-60-21		TD-125	
		YF-1 E-4	YET-60-1	TD-113	
e	FVD22-8	YF-1 E-4	YNE-38	DH-123 DH-113	
g	FVD2-4	YNT-1614			
h	FVD8-5	YF-1 E-4	YNE-38	DH-121 DH-111	
j (Noe 1)	60-S8	YPT-60N		TD-125	
		YF-1 E-4	YET-60-1	TD-113	
k (Note 1)	80-10	YPT-150-1		TD-227	
		YF-1 E-4	YET-150-1	TD-214	
l	FVD5.5-5	YNT-1210S			
m	FVD14-8	YF-1 E-4	YNE-38	DH-122 DH-112	
n	FVD38-8	YF-1 E-4	YNE-38	DH-124 DH-114	
o	FVD8-8	YF-1 E-4	YNE-38	DH-121 DH-111	
p	FVD5.5-8	YNT-1210S			
q (Note 1)	22-S5	YPT-60N		DH-123	
		YF-1 E-4	YET-60-1	DH-112	

- Note 1. Coat the crimping part with an insulation tube.
 2. Some crimp terminals may not be mounted.

8. OPTIONS AND PERIPHERAL EQUIPMENT

8.4.2 Connection of power regeneration converter unit and servo amplifier

POINT
<p>● When fuse is interposed in the wiring for the DC power supply between the converter unit and servo amplifier, use the wire whose size enable the protection coordination of the wire and fuse.</p>

The following shows the wires used for wiring. Use the wires given in this section or equivalent wires.

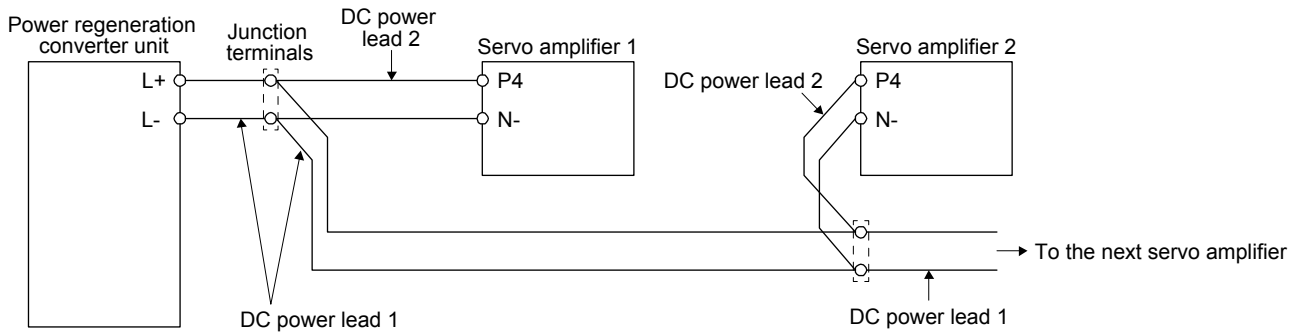

(1) Wire size

The following table indicates the connection wire sizes of the DC power supply (L+/P4 and L-/N-) between the MR-CV and servo amplifier. Use the 600 V grade heat-resistant polyvinyl chloride insulated wire (HIV wire) for wiring.

(a) 200 V

DC power supply lead 1 Total of servo amplifier capacities [kW]	DC power supply lead 2 Servo amplifier capacity	Wire[mm ²]
1.9 or less	100 W/200 W/400 W/ 600 W/750 W/1 kW	2 (AWG 14)
From over 1.9 to 3.1	2 kW	3.5 (AWG 12)
From over 3.1 to 5.2	3.5 kW/5 kW	5.5 (AWG 10)
From over 5.2 to 8.0	7 kW	8 (AWG 8)
From over 8.0 to 11.3	11 kW	14 (AWG 6)
From over 11.3 to 15.4	15 kW	22 (AWG 4)
From over 15.4 to 20.1		38 (AWG 2)
From over 20.1 to 26.2	22 kW	50 (AWG 1/0) (Note)
From over 26.2 to 27.5		60 (AWG 2/0) (Note)

Note. 50 mm² and 60 mm² wires cannot be installed to L + / L- of MR-CV_. Connect two wires whose total cross-sectional area of the conductor is equal to or larger than the cross-sectional area shown in this table or connect the wires one by one from TE2-1 or TE2-2.

(b) 400 V

DC power supply lead 1 Total of servo amplifier capacities [kW]	DC power supply lead 2 Servo amplifier capacity	Wire [mm ²]
4.4 or less	600 W/1 kW/2 kW/3.5 kW	2 (AWG 14)
From over 4.4 to 6.6	5 kW	3.5 (AWG 12)
From over 6.6 to 9.9	7 kW	5.5 (AWG 10)
From over 9.9 to 15.2	11 kW/15 kW	8 (AWG 8)
From over 15.2 to 22.1	22 kW	14 (AWG 6)
From over 22.1 to 27.5		22 (AWG 4)

8. OPTIONS AND PERIPHERAL EQUIPMENT

(c) Wire size selection example

When connecting multiple servo amplifiers, always use junction terminals for wiring the servo amplifier terminals P4 and N-. Also, connect the servo amplifiers in the order of larger to smaller capacities.

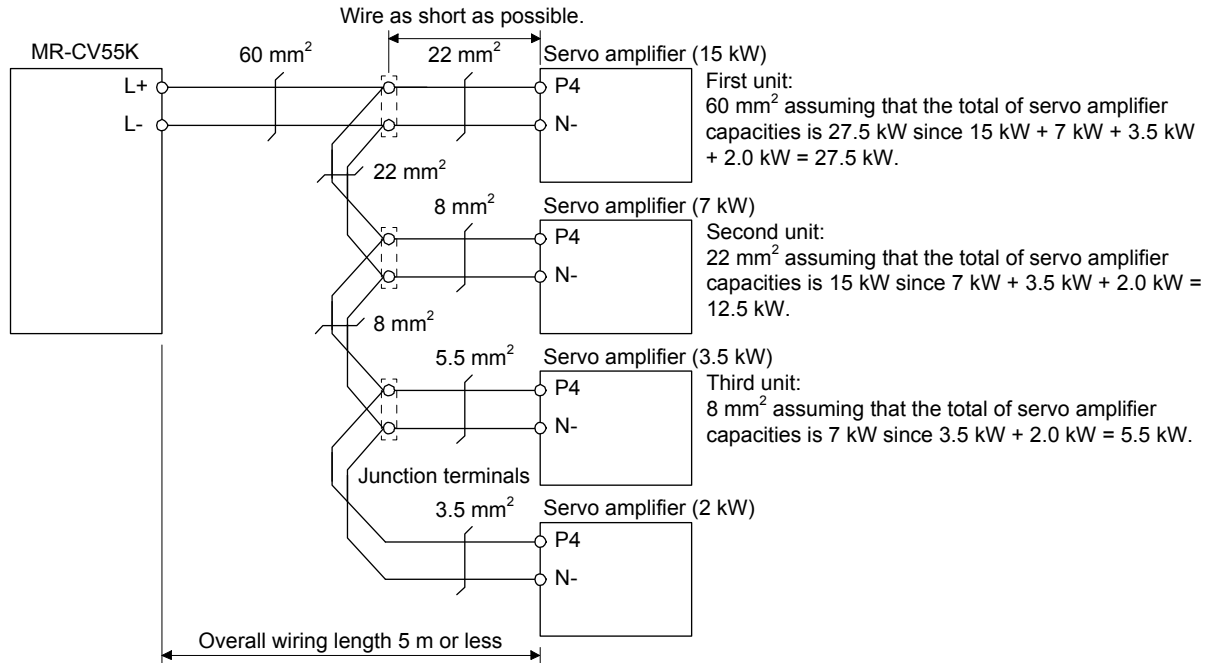

8. OPTIONS AND PERIPHERAL EQUIPMENT

8.5 Molded-case circuit breakers, fuses, magnetic contactors

8.5.1 For main circuit power supply



CAUTION

- To prevent the converter unit and the drive unit from smoke and a fire, select a molded-case circuit breaker which shuts off with high speed.
- Always use one molded-case circuit breaker and one magnetic contactor with one converter unit.

When using a fuse instead of the molded-case circuit breaker, use the one having the specifications given in this section.

Power regeneration converter unit	Molded-case circuit breaker (Note 1, 3)		Fuse			Magnetic contactor (Note 2)
	Frame, rated current	Voltage AC [V]	Class	Current [A]	Voltage AC [V]	
MR-CV11K	50 A frame 50 A	240	T	100	300	S-T35
MR-CV18K	100 A frame 100 A			175		S-T65
MR-CV30K	225 A frame 150 A			300		S-N125
MR-CV37K	225 A frame 175 A			350		S-N125
MR-CV45K	225 A frame 225 A			400		S-N150
MR-CV55K	400 A frame 300 A			600		S-N220
MR-CV11K4	30 A frame 30 A	480		50	600	S-T21
MR-CV18K4	50 A frame 50 A			100		S-T35
MR-CV30K4	100 A frame 80 A			175		S-T65
MR-CV37K4	100 A frame 100 A			200		S-T80
MR-CV45K4	125 A frame 125 A			250		S-T100
MR-CV55K4	225 A frame 150 A			300		S-N125
MR-CV75K4	225 A frame 200 A		350	S-N150		

- Note 1. For compliance with the IEC/EN/UL/CSA standard, refer to section 10.2.
2. Use a magnetic contactor with an operation delay time (interval between current being applied to the coil until closure of contacts) of 80 ms or less.
3. Use a molded-case circuit breaker having the operation characteristics equal to or higher than Mitsubishi Electric general-purpose products.

Resistance regeneration converter unit	Drive unit	Molded-case circuit breaker (Note 1, 3)			Fuse			Magnetic contactor (Note 2)
		Frame, rated current		Voltage AC [V]	Class	Current [A]	Voltage AC [V]	
		Power factor improving DC reactor is not used	Power factor improving DC reactor is used					
MR-CR55K	MR-J4-DU30K_(-RJ)	225 A frame 175 A	225 A frame 150 A	240	T	300	300	S-N150
	MR-J4-DU37K_(-RJ)	225 A frame 225 A	225 A frame 175 A			400		S-N180
MR-CR55K4	MR-J4-DU30K_4(-RJ)	100 A frame 100 A	100 A frame 80 A	480	T	175	600	S-N65 S-T65
	MR-J4-DU37K_4(-RJ)	125 A frame 125 A	100 A frame 100 A			200		S-N80 S-T80
	MR-J4-DU45K_4(-RJ)	225 A frame 150 A	125 A frame 125 A			300		S-N95 S-T100
	MR-J4-DU55K_4(-RJ)	225 A frame 175 A	225 A frame 150 A			300		S-N150

- Note 1. For compliance with the IEC/EN/UL/CSA standard, refer to section 10.2.
2. Use a magnetic contactor with an operation delay time (interval between current being applied to the coil until closure of contacts) of 80 ms or less.
3. Use a molded-case circuit breaker having the operation characteristics equal to or higher than Mitsubishi Electric general-purpose products.

8. OPTIONS AND PERIPHERAL EQUIPMENT

8.5.2 For control circuit power supply

Install an overcurrent protection device (molded-case circuit breaker or fuse) to protect the branch circuit.

(1) Converter unit

Converter unit	Molded-case circuit breaker (Note)		Fuse (Class T)		Fuse (Class K5)	
	Frame, rated current	Voltage AC [V]	Current [A]	Voltage AC [V]	Current [A]	Voltage AC [V]
MR-CR55K MR-CV11K MR-CV18K MR-CV30K MR-CV37K MR-CV45K	30 A frame 5 A	240	1	300	1	250
MR-CR55K4 MR-CV11K4 MR-CV18K4 MR-CV30K4 MR-CV37K4 MR-CV45K4 MR-CV55K4 MR-CV75K4	30 A frame 5 A	480	1	600	1	600

Note. When having the converter unit comply with the IEC/EN/UL/CSA standard, refer to section 10.2.

(2) Drive unit

Drive unit	Molded-case circuit breaker (Note)		Fuse (Class T)		Fuse (Class K5)	
	Frame, rated current	Voltage AC [V]	Current [A]	Voltage AC [V]	Current [A]	Voltage AC [V]
MR-J4-DU900B(-RJ) MR-J4-DU11KB(-RJ) MR-J4-DU15KB(-RJ) MR-J4-DU22KB(-RJ) MR-J4-DU30KB(-RJ) MR-J4-DU30KA(-RJ) MR-J4-DU37KB(-RJ) MR-J4-DU37KA(-RJ)	30 A frame 5 A	240	1	300	1	250
MR-J4-DU900B4(-RJ) MR-J4-DU11KB4(-RJ) MR-J4-DU15KB4(-RJ) MR-J4-DU22KB4(-RJ) MR-J4-DU30KB4(-RJ) MR-J4-DU30KA4(-RJ) MR-J4-DU37KB4(-RJ) MR-J4-DU37KA4(-RJ) MR-J4-DU45KB4(-RJ) MR-J4-DU45KA4(-RJ) MR-J4-DU55KB4(-RJ) MR-J4-DU55KA4(-RJ)	30 A frame 5 A	480	1	600	1	600

Note. When having the drive unit comply with the IEC/EN/UL/CSA standard, refer to section 10.2.

8. OPTIONS AND PERIPHERAL EQUIPMENT

(3) Passing wiring of the control circuit power supply

When the control circuit power supply is connected by passing wiring, wire L11 and L21 as follows. Use the 600 V grade heat-resistant polyvinyl chloride insulated wire (HIV wire) of 2 mm² (AWG 14) for wiring. The units are shown with the terminal cover open.

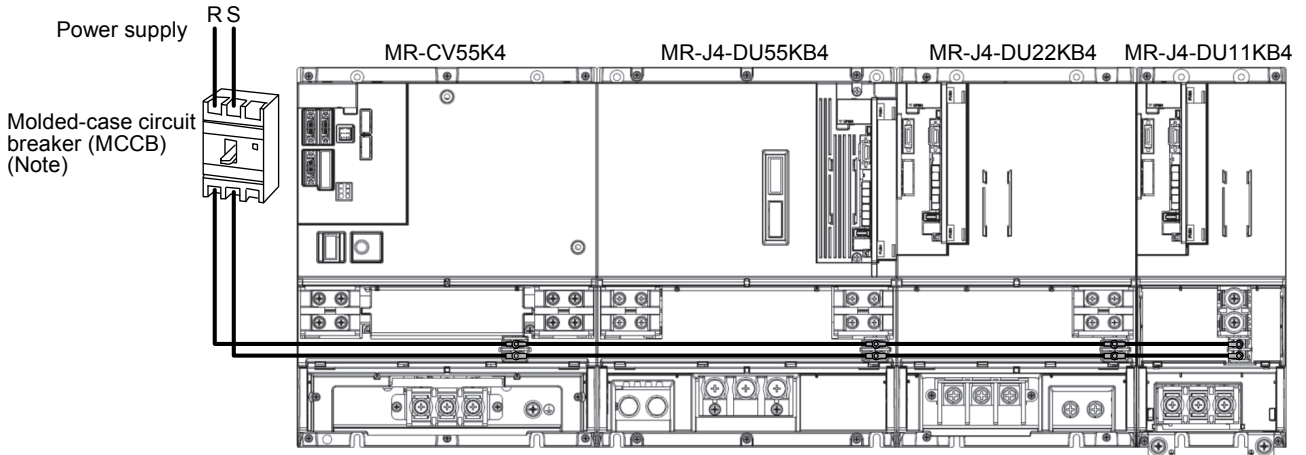

Note. Install a molded-case circuit breaker dedicated to the control circuit power supply. Do not use a molded-case circuit breaker for the main circuit power supply.

(a) Molded-case circuit breaker

Use AWG 14 wire for wiring. Use a molded-case circuit breaker having the operation characteristics not activated with a inrush current.

Model	Number of drive units					Voltage AC [V]
	1	2	3	4	5	
MR-CR55K	30 A frame 10 A	30 A frame 15 A				240
MR-CV11K	30 A frame 5 A					
MR-CV18K		30 A frame 10 A				
MR-CV30K						
MR-CV37K	30 A frame 10 A	30 A frame 15 A				
MR-CV45K						
MR-CV55K						
MR-CR55K4	30 A frame 10 A	30 A frame 10 A				480
MR-CV11K4	30 A frame 5 A					
MR-CV18K4		30 A frame 10 A				
MR-CV30K4						
MR-CV37K4						
MR-CV45K4	30 A frame 10 A	30 A frame 15 A				
MR-CV55K4						
MR-CV75K4				30 A frame 10 A		

8. OPTIONS AND PERIPHERAL EQUIPMENT

(b) Fuse

Use AWG 14 wire for wiring. Use a fuse having the fusing characteristics not blown with repeated inrush currents.

Model	Number of drive units					Voltage AC [V]
	1	2	3	4	5	
MR-CR55K	30 A frame 3 A					250
MR-CV11K	30 A frame 2 A	30 A frame 2 A	30 A frame 3 A	30 A frame 3 A	30 A frame 4 A	
MR-CV18K						
MR-CV30K	30 A frame 2 A	30 A frame 3 A	30 A frame 3 A	30 A frame 3 A	30 A frame 4 A	
MR-CV37K						
MR-CV45K						
MR-CV55K						
MR-CR55K4	30 A frame 5 A					600
MR-CV11K4	30 A frame 5 A	30 A frame 5 A	30 A frame 5 A	30 A frame 5 A	30 A frame 5 A	
MR-CV18K4						
MR-CV30K4	30 A frame 5 A	30 A frame 5 A	30 A frame 15 A	30 A frame 15 A	30 A frame 5 A	
MR-CV37K4						
MR-CV45K4						
MR-CV55K4						
MR-CV75K4						

8. OPTIONS AND PERIPHERAL EQUIPMENT

8.6 Power factor improving DC reactor

POINT
<ul style="list-style-type: none"> ●MR-DCL_ power factor improving DC reactor is for the MR-CR_ resistance regeneration converter unit. MR-DCL_ cannot be used with the MR-CV_ power regeneration converter unit.

The following shows the advantages of using power factor improving DC reactor.

- It improves the power factor by increasing the form factor of the resistance regeneration converter unit's input current.
- It decreases the power supply capacity.
- The input power factor is improved to about 95%.

When connecting the power factor improving DC reactor to the resistance regeneration converter unit, be sure to remove the short bar across P1 and P2. If it remains connected, the effect of the power factor improving DC reactor is not produced.

When used, the power factor improving DC reactor generates heat. To release heat, therefore, leave a 10 cm or more clearance at each of the top and bottom, and a 5 cm or more clearance on each side.

Resistance regeneration converter unit	Drive unit	Power factor improving DC reactor	Variable dimensions [mm]					Terminal screw	Mass [kg]
			W	D	H	W1	X		
MR-CR55K	MR-J4-DU30K_(-RJ)	MR-DCL30K	135	255	215	80	232	M12	9.5
	MR-J4-DU37K_(-RJ)	MR-DCL37K							
MR-CR55K4	MR-J4-DU30K_4(-RJ)	MR-DCL30K-4		205	200	75	175	M8	6.5
	MR-J4-DU37K_4(-RJ)	MR-DCL37K-4		225			197		7
	MR-J4-DU45K_4(-RJ)	MR-DCL45K-4		240		80	212		7.5
	MR-J4-DU55K_4(-RJ)	MR-DCL55K-4		260		215	232		9.5

[Unit: mm]

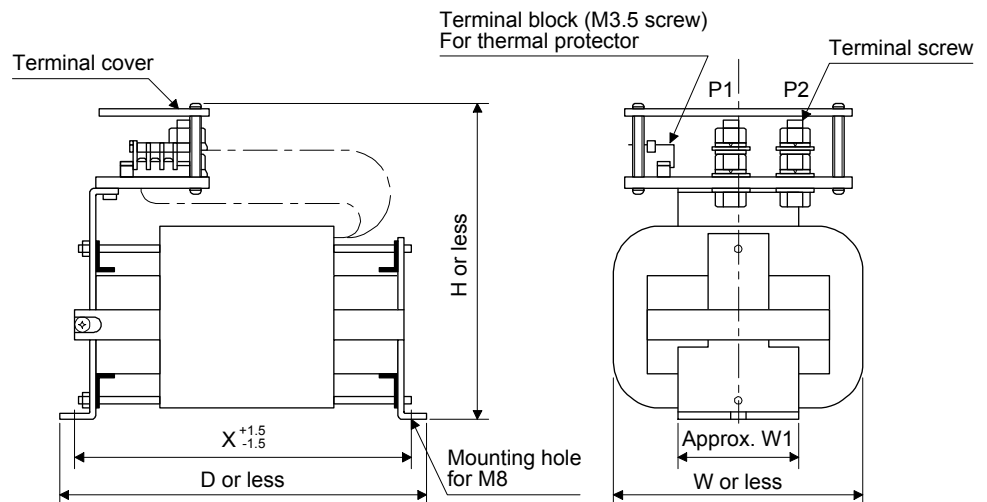

8. OPTIONS AND PERIPHERAL EQUIPMENT

8.7 AC reactor

POINT
●MR-AL_ AC reactor is for the MR-CV_ power regeneration converter unit. MR-AL_ cannot be used with the MR-CR_ resistance regeneration converter unit.

Power regeneration converter unit	AC reactor	Variable dimensions [mm]						Terminal screw	Mass [kg]
		W	D	H	W1	X	d		
MR-CV11K	MR-AL-11K	145	175	155	75	55	M6	M5	3.7
MR-CV18K	MR-AL-18K	145	175	155	105	55	M6	M6	5.3
MR-CV30K	MR-AL-30K	145	175	155	110	55	M6	M6	6.1
MR-CV37K	MR-AL-37K	150	215	175	110	70	M6	M6	8.6
MR-CV45K	MR-AL-45K	160	215	175	120	70	M6	M6	9.7
MR-CV55K	MR-AL-55K	230	220	192	120	200	M8	M10	11.5
MR-CV11K4	MR-AL-11K4	145	175	155	75	55	M6	M5	3.7
MR-CV18K4	MR-AL-18K4	145	175	155	105	55	M6	M6	5.3
MR-CV30K4	MR-AL-30K4	145	175	155	110	55	M6	M6	6.0
MR-CV37K4	MR-AL-37K4	150	215	175	110	70	M6	M6	8.5
MR-CV45K4	MR-AL-45K4	160	215	175	120	70	M6	M6	9.8
MR-CV55K4	MR-AL-55K4	230	220	210	120	200	M8	M6	10.5
MR-CV75K4	MR-AL-75K4	230	250	215	143	230	M8	M6	13.0

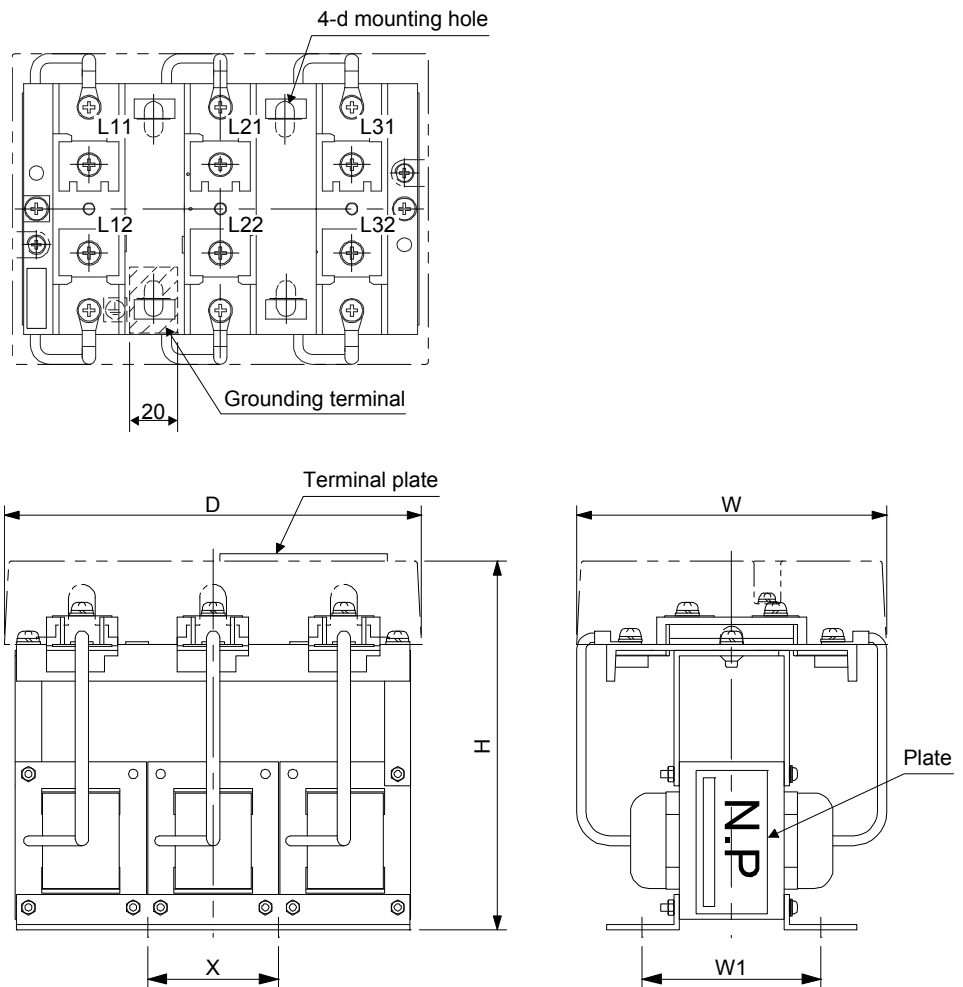

8. OPTIONS AND PERIPHERAL EQUIPMENT

8.8 Noise reduction techniques

Noises are classified into external noises which enter the converter unit and drive unit to cause them to malfunction and those radiated by the converter unit and drive unit to cause peripheral equipment to malfunction. Since the converter unit and drive unit are electronic devices which handle small signals, the following general noise reduction techniques are required.

Also, the drive unit can be a source of noise as its outputs are chopped by high carrier frequencies. If peripheral equipment malfunctions due to noise generation, take noise suppression measures. The measures will vary slightly with the routes of noise transmission.

8.8.1 Noise reduction techniques

(1) General reduction techniques

- Avoid bundling power lines (input/output) and signal cables of the converter unit/drive unit together or running them in parallel to each other. Separate the power lines from the signal cables.
- Use a shielded twisted pair cable for connection with the encoder and for control signal transmission, and connect the external conductor of the cable to the SD terminal.
- Ground the converter unit, drive unit and the servo motor, etc. together at one point. (Refer to section 3.4.8 and section 4.3.8.)

(2) Reduction techniques for external noises that cause the converter unit/drive unit to malfunction

If there are noise sources (such as a magnetic contactor, an electromagnetic brake, and many relays which make a large amount of noise) near the converter unit and drive unit and the converter unit/drive unit may malfunction, the following countermeasures are required.

- Provide surge killers on the noise sources to suppress noises.
- Attach data line filters to the signal cables.
- Ground the shields of the encoder connecting cable and the control signal cables with cable clamp fittings.
- Although a surge absorber is built into the converter unit, to protect the converter unit, drive unit and other equipment against large exogenous noise and lightning surge, attaching a varistor to the power input section of the equipment is recommended.

8. OPTIONS AND PERIPHERAL EQUIPMENT

- (3) Techniques for noises radiated by the converter unit/drive unit that cause peripheral equipment to malfunction

Noises produced by the converter unit and drive unit are classified into those radiated from the cables connected to the converter unit, drive unit and their main circuits (input and output circuits), those induced electromagnetically or statically by the signal cables of the peripheral equipment located near the main circuit cables, and those transmitted through the power supply cables.

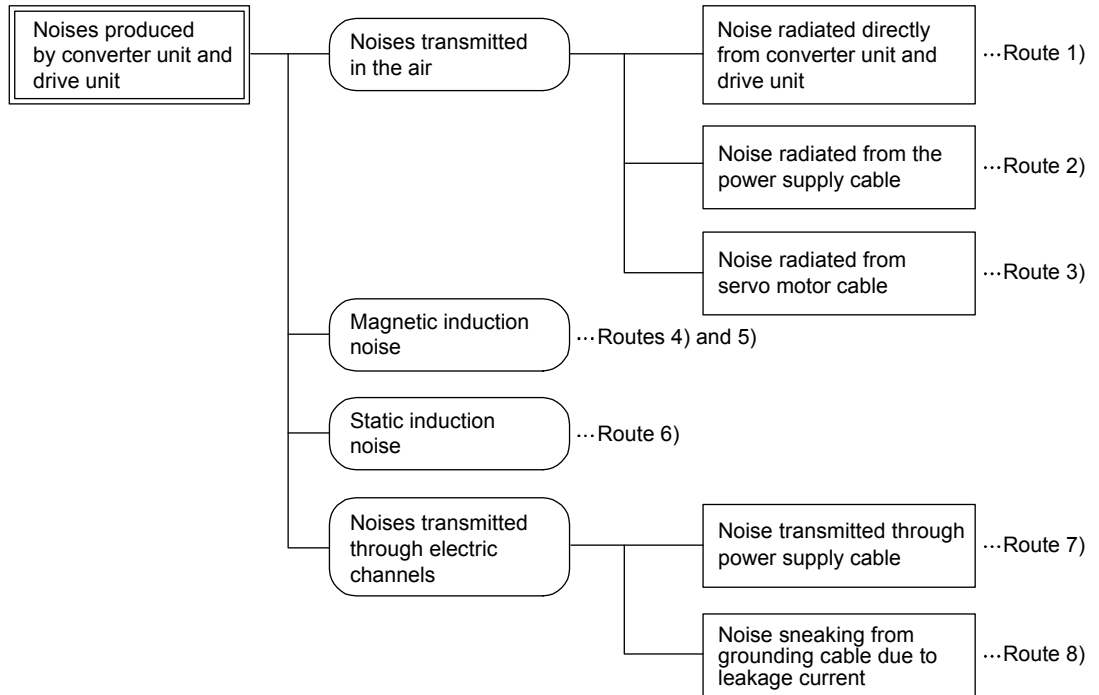

8. OPTIONS AND PERIPHERAL EQUIPMENT

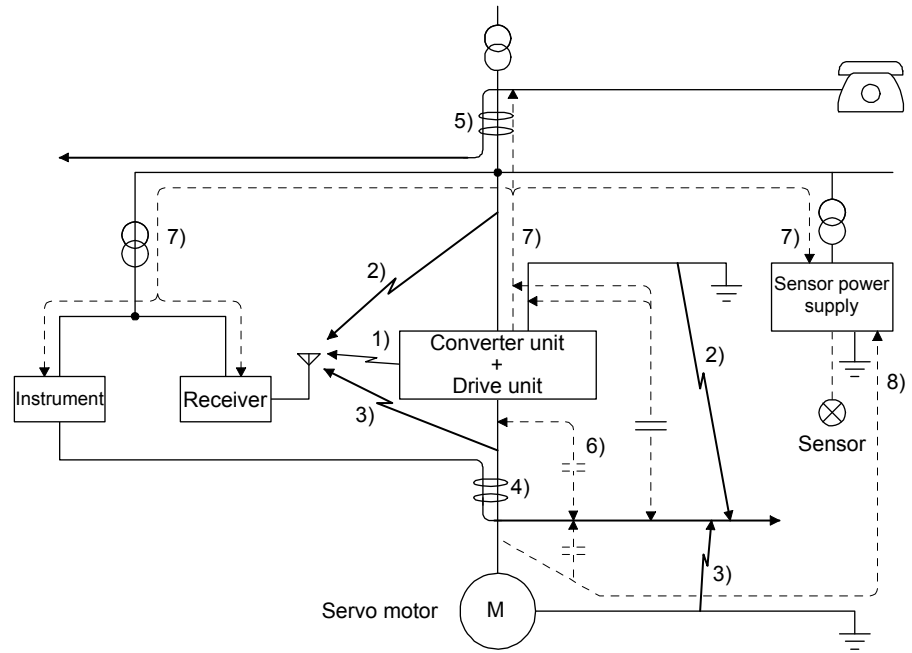

Noise transmission route	Suppression techniques
1) 2) 3)	<p>When measuring instruments, receivers, sensors, etc. which handle weak signals and may malfunction due to noise and/or their signal cables are contained in a cabinet together with the converter unit and drive unit or run near the converter unit and drive unit, such devices may malfunction due to noises transmitted through the air. The following techniques are required.</p> <ol style="list-style-type: none"> 1. Provide maximum clearance between easily affected devices and the converter unit/drive unit. 2. Provide maximum clearance between easily affected signal cables and the I/O cables of the converter unit/drive unit. 3. Avoid wiring the power lines (input/output lines of the converter unit/drive unit) and signal lines side by side or bundling them together. 4. Insert a line noise filter to the I/O cables or a radio noise filter on the input line. 5. Use shielded wires for signal and power lines or put lines in separate metal conduits.
4) 5) 6)	<p>When the power lines and the signal lines are laid side by side or bundled together, magnetic induction noise and static induction noise will be transmitted through the signal cables and malfunction may occur. The following techniques are required.</p> <ol style="list-style-type: none"> 1. Provide maximum clearance between easily affected devices and the converter unit/drive unit. 2. Provide maximum clearance between easily affected signal cables and the I/O cables of the converter unit/drive unit. 3. Avoid wiring the power lines (input/output lines of the converter unit/drive unit) and signal lines side by side or bundling them together. 4. Use shielded wires for signal and power lines or put lines in separate metal conduits.
7)	<p>When the power supply of peripheral equipment is connected to the power supply of the converter unit/drive unit systems, noises produced by the converter unit and drive unit may be transmitted back through the power supply cable and the devices may malfunction. The following techniques are required.</p> <ol style="list-style-type: none"> 1. Install the radio noise filter (FR-BIF(-H)) on the power lines (Input lines) of the converter unit/drive unit. 2. Install the line noise filter (FR-BLF) on the power lines of the converter unit/drive unit.
8)	<p>If the grounding wires of the peripheral equipment and the servo amplifier make a closed loop circuit, leakage current may flow through, causing the equipment to malfunction. In this case, the malfunction may be prevented by the grounding wires disconnected from the equipment.</p>

8. OPTIONS AND PERIPHERAL EQUIPMENT

8.8.2 Noise reduction techniques

This section explains how to use the line noise filter unique to the converter unit and drive unit. Other noise reduction products are the same as those for MR-J4-_-(-RJ). When you use MR-J4-DU_A_-(-RJ), refer to section 11.14 (2) of "MR-J4-_A_-(-RJ) Servo Amplifier Instruction Manual". When you use MR-J4-DU_B_-(-RJ), refer to section 11.14 (2) of "MR-J4-_B_-(-RJ) Servo Amplifier Instruction Manual".

(1) Line noise filter (FR-BLF)

This filter is effective in suppressing noises radiated from the power supply side and output side of the converter unit, drive unit and also in suppressing high-frequency leakage current (0-phase current). It especially affects the noises between 0.5 MHz and 5 MHz band. The filters are used with the main circuit power supply of the converter unit (L1/L2/L3) and the power output of the drive unit (U/V/W).

(a) Usage

Pass the 3-phase wires through four line noise filters. When you use the line noise filters with the power wires, passing the power wires together with the ground wire will reduce the filter effect. Run the ground wire separately from the power wires.

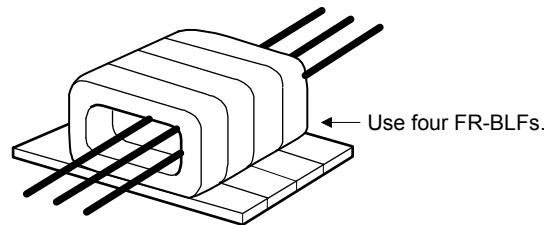

(b) Dimensions

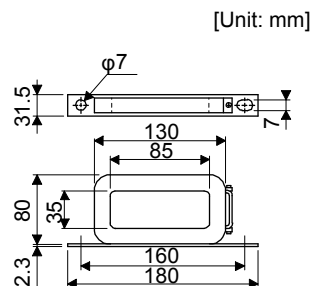

8. OPTIONS AND PERIPHERAL EQUIPMENT

8.9 Earth-leakage current breaker

8.9.1 Selection method

High-frequency chopper currents controlled by pulse width modulation flow in the AC servo circuits. Leakage currents containing harmonic contents are larger than those of the motor which is run with a commercial power supply.

Select an earth-leakage current breaker according to the following formula, and ground the converter unit, drive unit, servo motor, etc. securely.

To minimize leakage currents, make the input and output wires as short as possible, and keep a distance of 30 cm or longer between the wires and ground.

$$\text{Rated sensitivity current} \geq 10 \cdot \{I_{g1} + I_{gn} + I_{ga} + K \cdot (I_{g2} + I_{gm})\} \text{ [mA]}$$

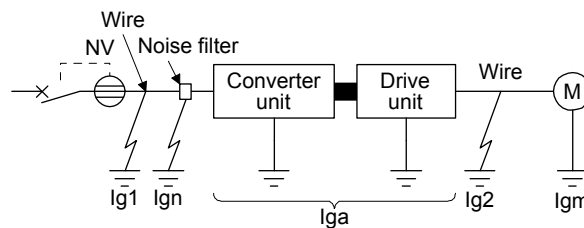

Earth-leakage current breaker		K
Type	Mitsubishi products	
Models provided with harmonic and surge reduction techniques	NV-SV NV-SVF NV-SW NV-CV NV-CVF NV-CW NV-HV	1
General models	BV-C1	3

I_{g1} : Leakage current on the electric channel from the earth-leakage current breaker to the input terminals of the drive unit (found from (1) in this section.)

I_{g2} : Leakage current on the electric channel from the output terminals of the drive unit to the servo motor (found from (1) in this section.)

I_{gn} : Leakage current when a filter is connected to the input side (4.4 mA per one FR-BIF(-H))

I_{ga} : Leakage current of the converter unit/drive unit (found from (2) in this section.)

I_{gm} : Leakage current of the servo motor (found from (3) in this section.)

8. OPTIONS AND PERIPHERAL EQUIPMENT

- (1) Example of leakage current per km (I_{g1} , I_{g2}) for CV cable run in metal conduit
 (a) 200 V class

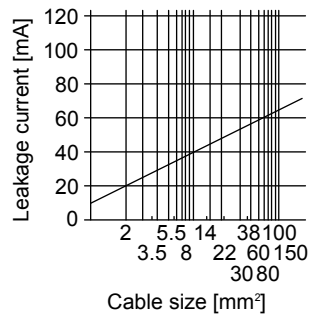

- (b) 400 V class

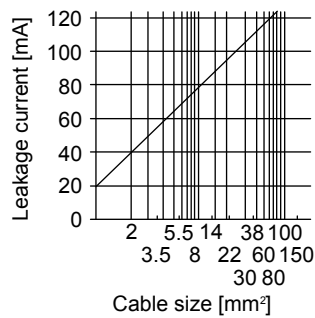

- (2) Converter unit/drive unit's leakage current example (I_{ga})

Converter unit Drive unit	Leakage current [mA]
All series	5

- (3) Servo motor leakage current example (I_{gm})

Servo motor output [kW]	Leakage current [mA]
6 to 55	2.5

8. OPTIONS AND PERIPHERAL EQUIPMENT

8.9.2 Selection example

Indicated below is an example of selecting an earth-leakage current breaker under the following conditions.

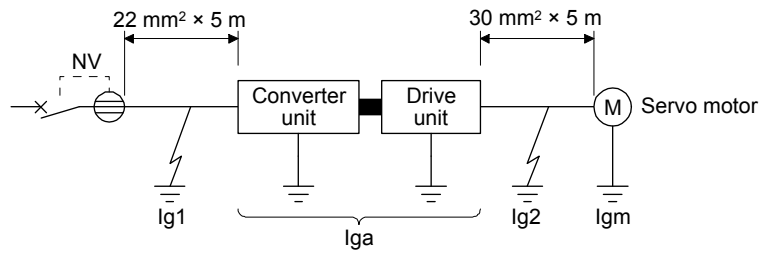

Use an earth-leakage current breaker designed for suppressing harmonics/surges.
Calculate the terms of equation in section 8.9.1 from the figure.

$$I_{g1} = 95 \times \frac{5}{1000} = 0.475 \text{ [mA]}$$

$$I_{g2} = 105 \times \frac{5}{1000} = 0.525 \text{ [mA]}$$

$$I_{gn} = 0 \text{ (not used)}$$

$$I_{ga} = 5 \text{ [mA]}$$

$$I_{gm} = 2.5 \text{ [mA]}$$

Substitute these values in the equation in section 8.9.1.

$$I_g \geq 10 \cdot \{0.475 + 0 + 5 + 1 \cdot (0.525 + 2.5)\} \\ \geq 85 \text{ [mA]}$$

According to the result of calculation, use an earth-leakage current breaker having the rated sensitivity current (I_g) of 85 mA or more. Use an earth-leakage current breaker having I_g of 200 mA with the NV-SV/NV-SVF/NV-SW/NV-CV/NV-CVF/NV-CW/NV-HV series.

8. OPTIONS AND PERIPHERAL EQUIPMENT

8.10 EMC filter (recommended)

POINT
<p>● When connecting multiple converter units to one EMC filter, refer to section 6.4 of "EMC Installation Guidelines".</p>

It is recommended that one of the following filters be used to comply with EN EMC directive. Some EMC filters have a large leakage current.

8.10.1 Combinations with the converter unit

Converter unit	Recommended filter (Soshin Electric)				Mass [kg]
	Model	Rated current [A]	Rated voltage [VAC]	Leakage current [mA]	
MR-CV11K MR-CV18K	HF3100A-UN (Note)	100	250	6.5	12
MR-CV30K MR-CV37K MR-CV45K MR-CV55K MR-CR55K	HF3200A-UN (Note)	200		9	18
MR-CV11K4 MR-CV18K4	TF3030C-TX TF3060C-TX	30 60	500	5.5	7.5 12.5
MR-CV30K4 MR-CV37K4 MR-CV45K4 MR-CV55K4 MR-CV75K4 MR-CR55K4	TF3150C-TX	150			31

Note. A surge protector is separately required to use any of these EMC filters.

Converter unit	Recommended filter (COSEL)				Mass [kg]
	Model	Rated current [A]	Rated voltage [VAC]	Leakage current [mA]	
MR-CV11K MR-CV18K	FTB-100-355-L (Note)	100	500	40	5.3
MR-CV11K4 MR-CV18K4	FTB-80-355-L (Note)	80	500	80	5.3
MR-CV30K4 MR-CV37K4 MR-CV45K4 MR-CV55K4 MR-CV75K4 MR-CR55K4	FTB-150-355-L (Note)	150	500	80	7.8

Note. A surge protector is separately required to use any of these EMC filters.

8. OPTIONS AND PERIPHERAL EQUIPMENT

8.10.2 Connection example

(1) For MR-CV_ power regeneration converter unit

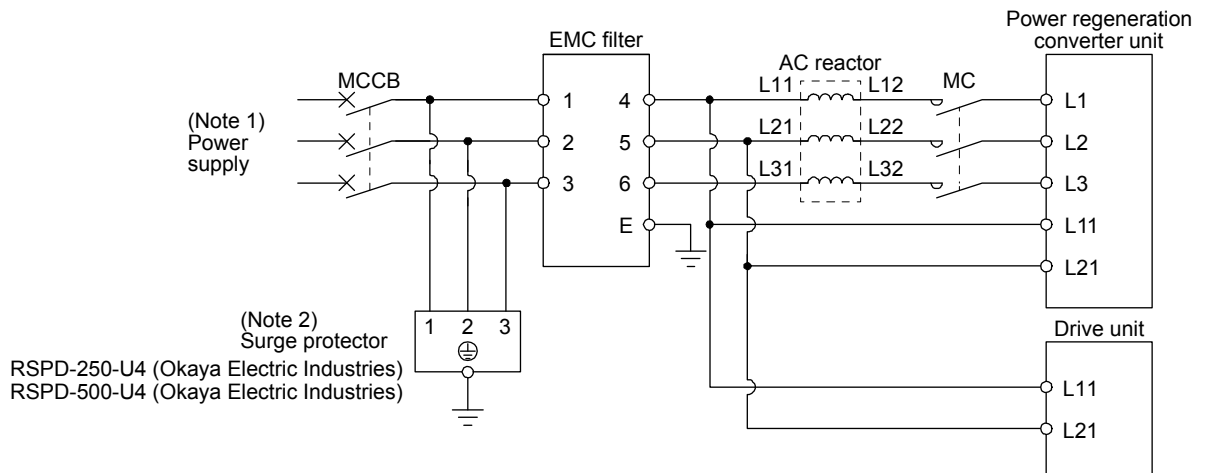

- Note 1. For the power supply specifications, refer to section 1.4.
2. The example is when a surge protector is connected.

(2) MR-CR_ resistance regeneration converter unit

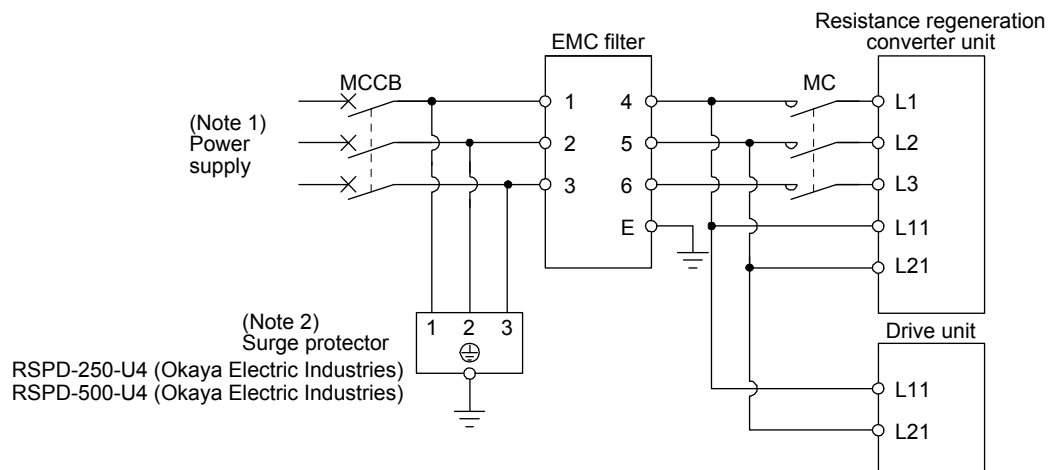

- Note 1. For the power supply specifications, refer to section 1.4.
2. The example is when a surge protector is connected.

8. OPTIONS AND PERIPHERAL EQUIPMENT

8.10.3 Dimensions

(1) EMC filter

(a) HF3100A-UN

[Unit: mm]

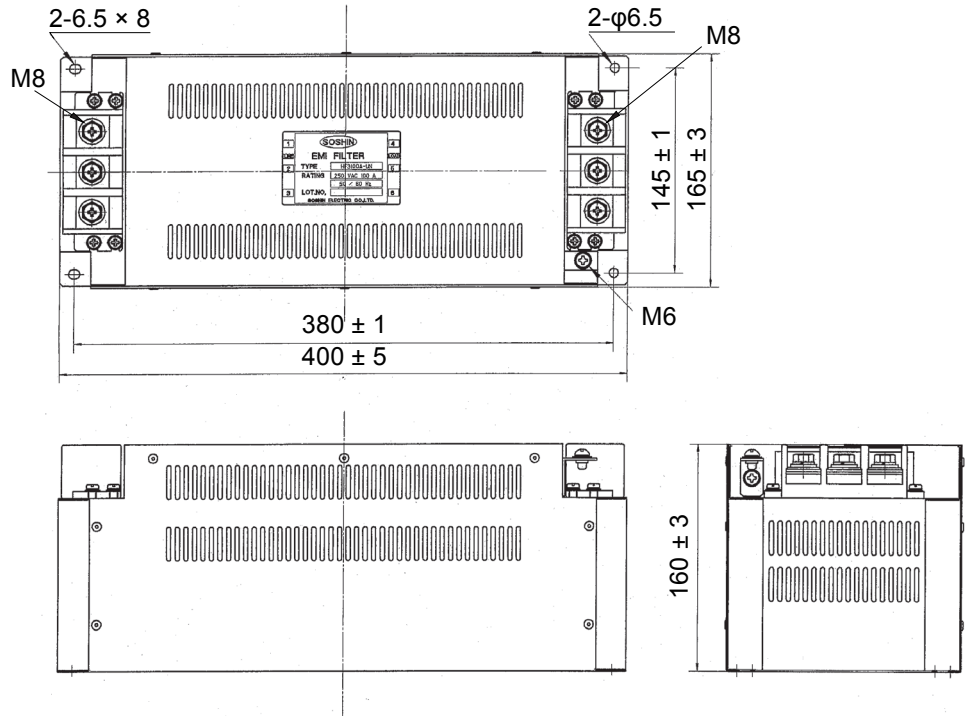

(b) HF3200A-UN

[Unit: mm]

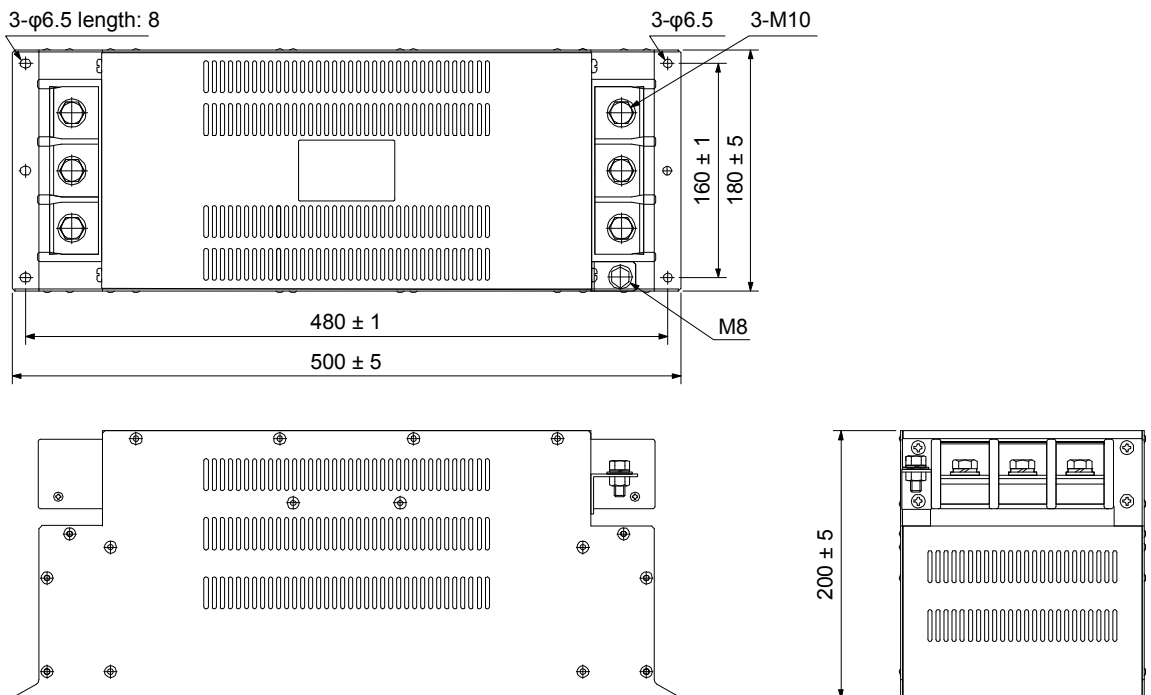

8. OPTIONS AND PERIPHERAL EQUIPMENT

(c) TF3030C-TX

[Unit: mm]

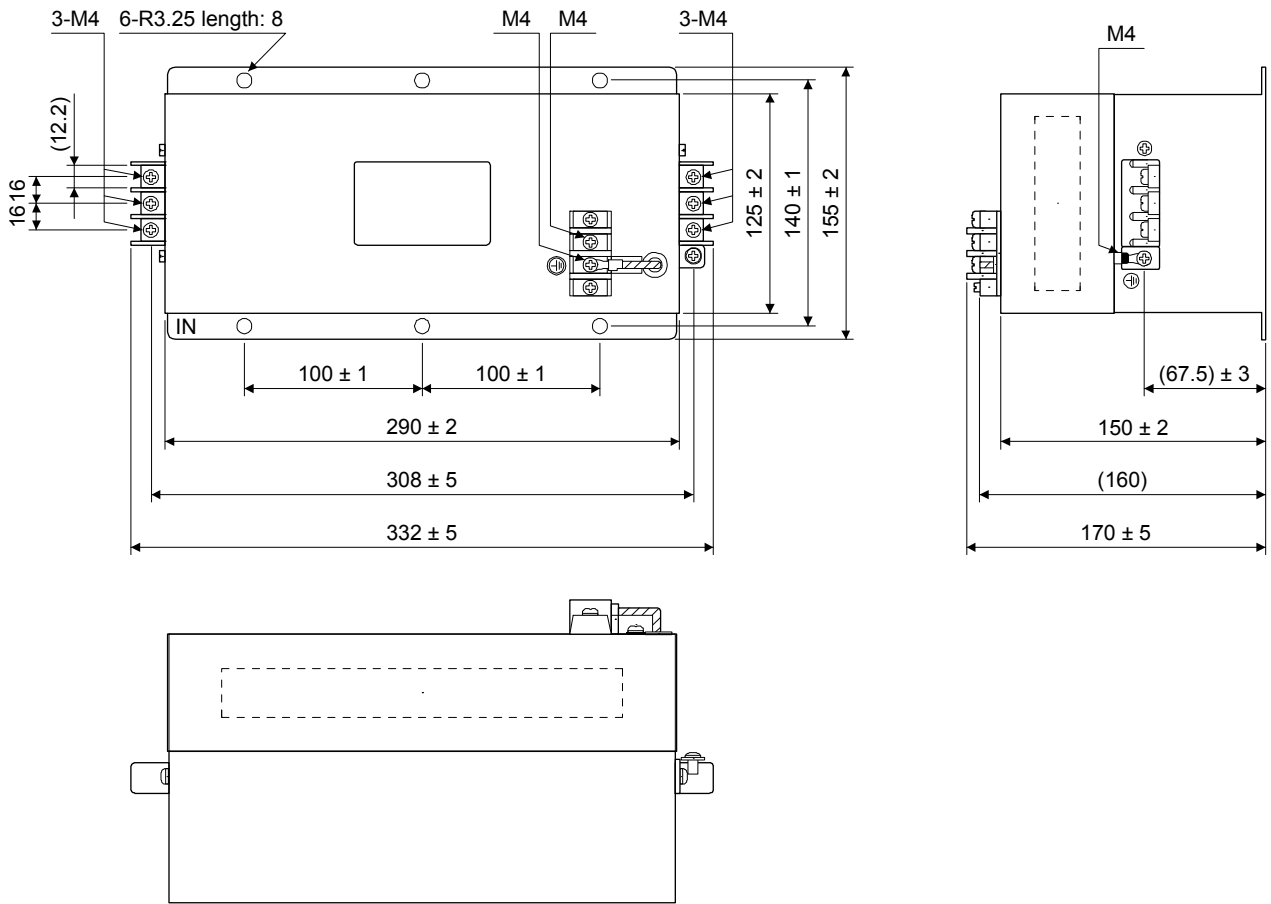

8. OPTIONS AND PERIPHERAL EQUIPMENT

(d) TF3060C-TX

[Unit: mm]

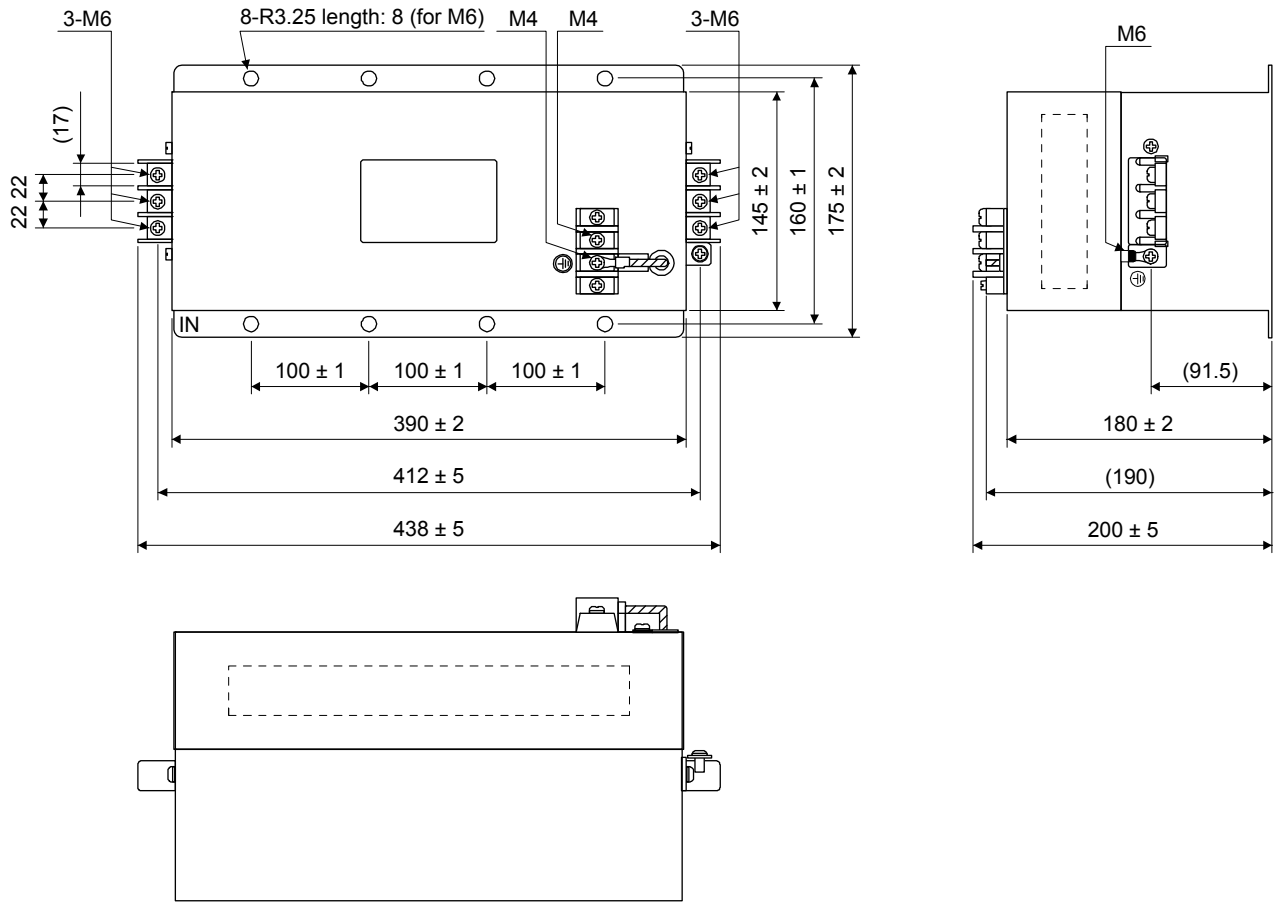

(e) TF3150C-TX

[Unit: mm]

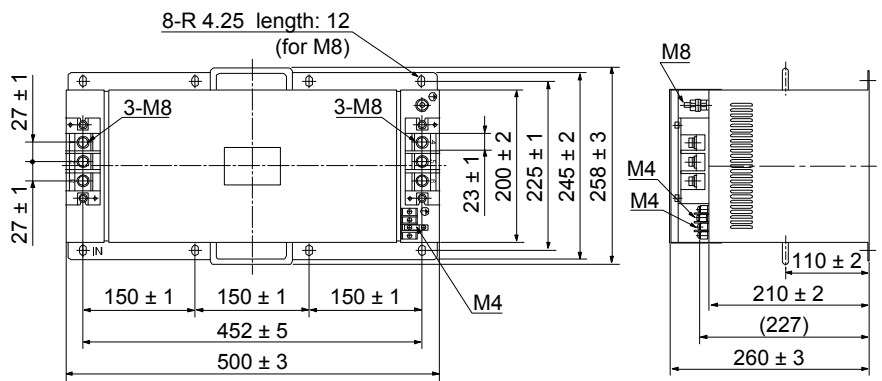

8. OPTIONS AND PERIPHERAL EQUIPMENT

- (f) FTB-80-355-L/FTB-100-355-L/FTB-150-355-L
 The values in brackets are only for FTB-150-355-L.

[Unit: mm]

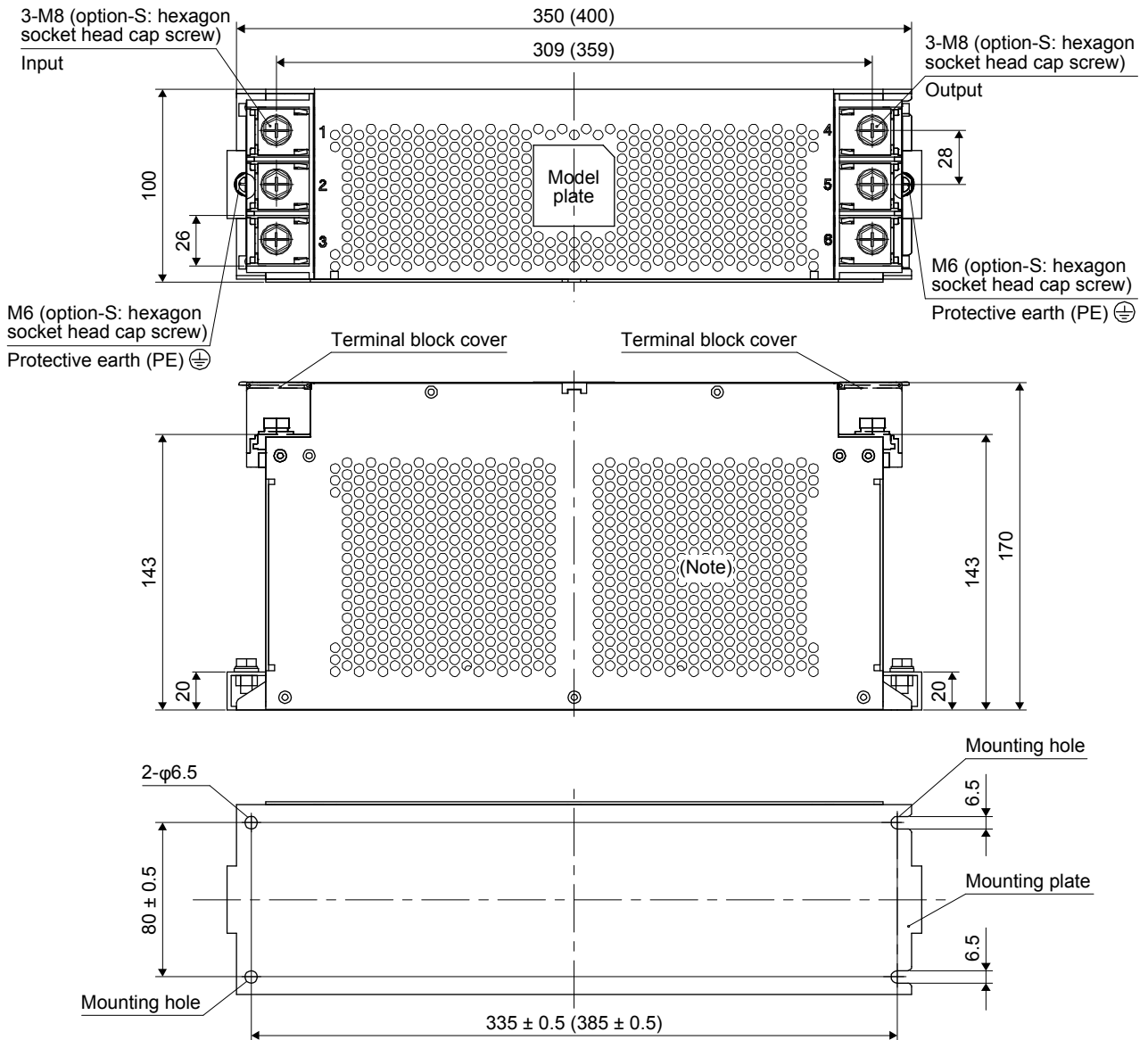

Note. No heat radiation holes on the opposite side.

8. OPTIONS AND PERIPHERAL EQUIPMENT

(2) Surge protector (RSPD-250-U4/RSPD-500-U4)

[Unit: mm]

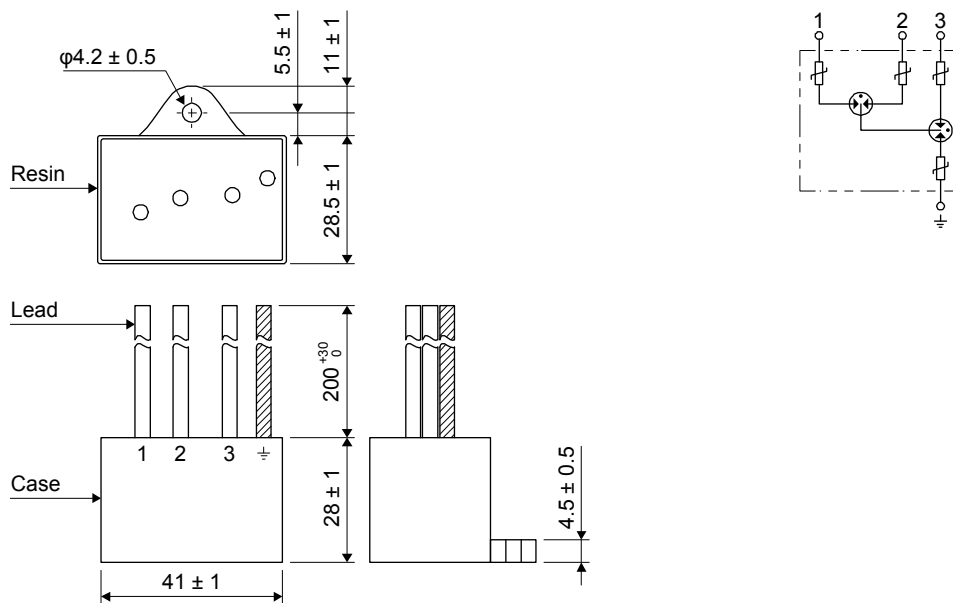

8. OPTIONS AND PERIPHERAL EQUIPMENT

8.11 FR-BU2-(H) brake unit

POINT							
●	FR-BU2_ brake unit is for the MR-CR_ resistance regeneration converter unit. FR-BU2_ cannot be used with the MR-CV_ power regeneration converter unit.						
●	EM2 of the drive unit is the signal having the same contents as EM1 of the drive unit in torque control mode.						
●	Use a 200 V class brake unit and a resistor unit with a 200 V class resistance regeneration converter unit, and a 400 V class brake unit and a resistor unit with a 400 V class resistance regeneration converter unit. Combination of different voltage class units cannot be used.						
●	When a brake unit and a resistor unit are installed horizontally or diagonally, the heat dissipation effect diminishes. Install them on a flat surface vertically.						
●	The temperature of the resistor unit case will be higher than the ambient temperature by 100 °C or over. Keep cables and flammable materials away from the case.						
●	Ambient temperature condition of the brake unit is between -10 °C and 50 °C. Note that the condition is different from the ambient temperature condition of the resistance regeneration converter unit (between 0 °C and 55 °C).						
●	Configure the circuit to shut down the power-supply with the alarm output of the brake unit and the resistor unit under abnormal condition.						
●	Use the brake unit with a combination indicated in section 8.11.1.						
●	Brake unit and regenerative options (Regenerative resistor) cannot be used simultaneously.						
●	When using the brake unit, set the parameters as follows.						
	<table border="1" style="width: 100%; border-collapse: collapse;"> <thead> <tr> <th style="width: 70%;">Parameter</th> <th style="width: 30%;">Setting value</th> </tr> </thead> <tbody> <tr> <td>[Pr. PA01] of the resistance regeneration converter unit</td> <td style="text-align: center;">__ 0 0 (Initial value)</td> </tr> <tr> <td>[Pr. PA02] of the drive unit</td> <td style="text-align: center;">__ 0 1</td> </tr> </tbody> </table>	Parameter	Setting value	[Pr. PA01] of the resistance regeneration converter unit	__ 0 0 (Initial value)	[Pr. PA02] of the drive unit	__ 0 1
Parameter	Setting value						
[Pr. PA01] of the resistance regeneration converter unit	__ 0 0 (Initial value)						
[Pr. PA02] of the drive unit	__ 0 1						

Connect the brake unit to the bus of the resistance regeneration converter unit (L+ and L- of TE2-1) for use. As compared to the MR-RB regenerative option, the brake unit can return larger power. Use the brake unit when the regenerative option cannot provide sufficient regenerative capability. When using the brake unit, always refer to "FR-BU2 Brake Unit Instruction Manual".

8.11.1 Selection

Use a combination of resistance regeneration converter unit, brake unit and resistor unit listed below.

Brake unit		Resistor unit	Number of connected units	Permissible continuous power [kW]	Resultant resistance [Ω]	Resistance regeneration converter unit
200 V class	FR-BU2-55K	FR-BR-55K	2 (parallel)	7.82	1	MR-CR55K
		MT-BR5-55K	2 (parallel)	11.0	1	
400 V class	FR-BU2-H55K	FR-BR-H55K	2 (parallel)	7.82	4	MR-CR55K4
		FR-BU2-H75K	2 (parallel)	15.0	3.25	

8. OPTIONS AND PERIPHERAL EQUIPMENT

8.11.2 Brake unit parameter setting

Normally, changing the FR-BU2-(H) parameter is not required. Whether a parameter can be changed or not is listed below.

Parameter		Change possible/ impossible	Remark
No.	Name		
0	Brake mode switchover	Impossible	Do not change the parameter.
1	Monitor display data selection	Possible	Refer to "FR-BU2 Brake Unit Instruction Manual".
2	Input terminal function selection 1	Impossible	Do not change the parameter.
3	Input terminal function selection 2		
77	Parameter write selection		
78	Cumulative energization time carrying-over times		
CLr	Parameter clear		
ECL	Alarm history clear		
C1	For manufacturer setting		

8.11.3 Connection example of combination with FR-BR-(H) resistor unit

POINT

- Connecting PR terminal of the brake unit to L+ terminal of the resistance regeneration converter unit results in a brake unit malfunction. Always connect the PR terminal of the brake unit to the PR terminal of the resistor unit.
- To use brake units with a parallel connection, use two sets of FR-BU2-(H) brake unit. Combination with other brake unit results in alarm occurrence or malfunction.
- Always connect the terminals for master/slave (MSG to MSG, SD to SD) between the two brake units.
- Do not connect as follows.

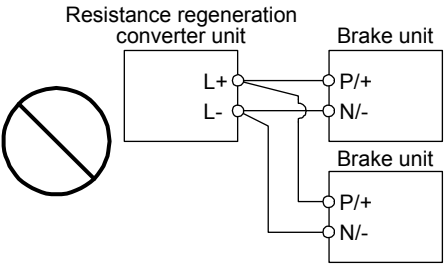

Connecting two cables to L+ and L- terminals

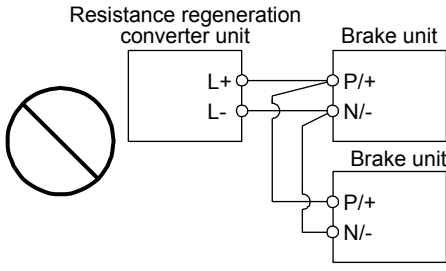

Passing wiring

8. OPTIONS AND PERIPHERAL EQUIPMENT

(1) When magnetic contactor drive output is enabled

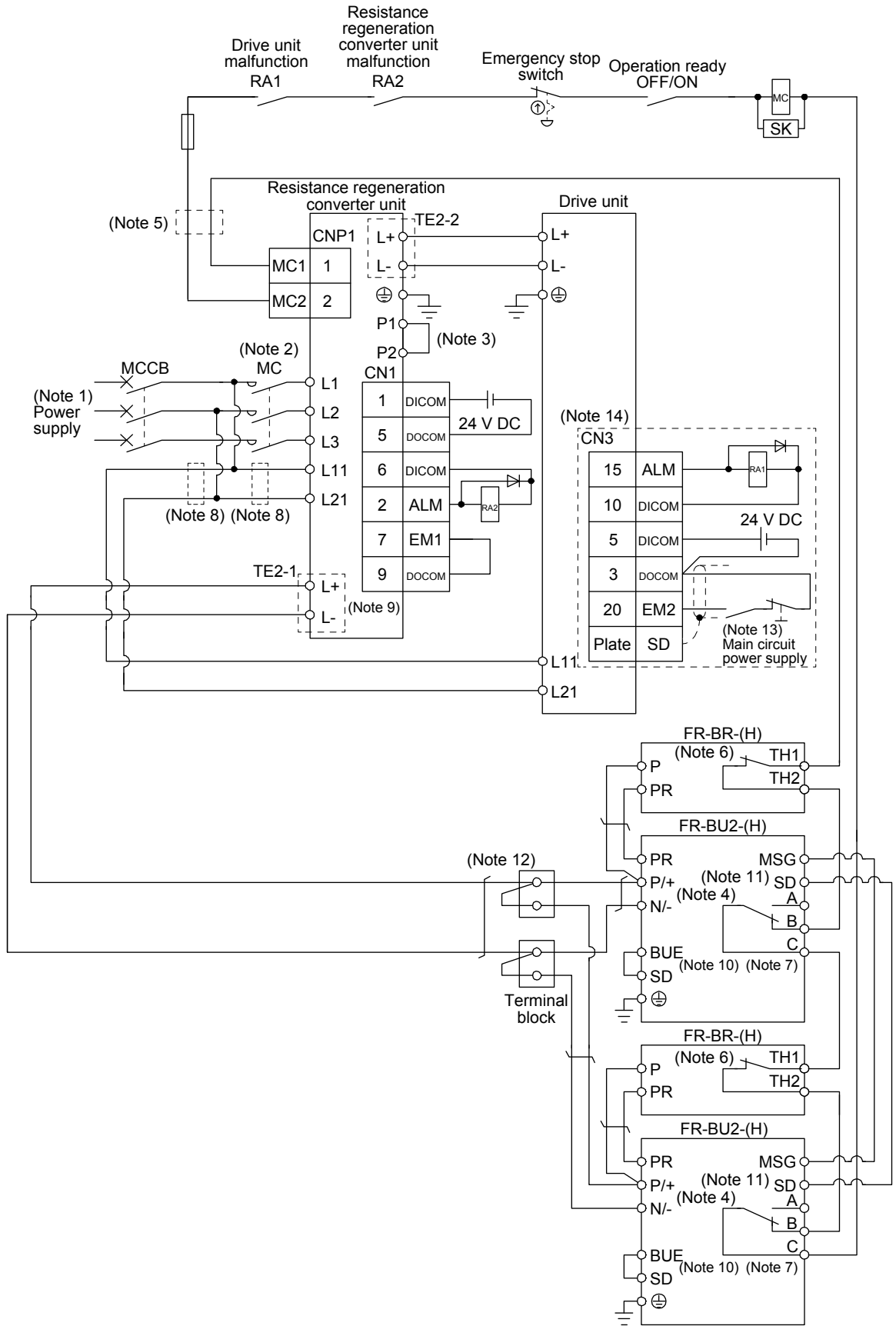

8. OPTIONS AND PERIPHERAL EQUIPMENT

- Note
1. For the power supply specifications, refer to section 1.4.
 2. Use a magnetic contactor with an operation delay time (interval between current being applied to the coil until closure of contacts) of 80 ms or less. Depending on the main circuit voltage and operation pattern, bus voltage decreases, and that may cause the forced stop deceleration to shift to the dynamic brake deceleration. When dynamic brake deceleration is not required, slow the time to turn off the magnetic contactor.
 3. P1 and P2 are connected by default. When using the power factor improving DC reactor, connect P1 and P2 after removing the short bar across them. Refer to section 8.6 for details.
 4. Connect P/+ and N/- terminals of the brake unit to a correct destination. Incorrect connection destination results in the resistance regeneration converter unit and brake unit malfunction.
 5. For 400 V class, a step-down transformer is required.
 6. Contact rating: 1b contact, 110 V AC, 5 A/220 V AC, 3 A
Normal condition: TH1-TH2 is conducting. Abnormal condition: TH1-TH2 is not conducting.
 7. Contact rating: 230 V AC, 0.3 A/30 V DC, 0.3 A
Normal condition: B-C is conducting./A-C is not conducting. Abnormal condition: B-C is not conducting./A-C is conducting.
 8. Install an overcurrent protection device (molded-case circuit breaker or fuse) to protect the branch circuit. (Refer to section 8.5.)
 9. Do not connect more than one cable to each L+ and L- terminals of TE2-1 of the resistance regeneration converter unit.
 10. Always connect BUE and SD terminals. (factory-wired)
 11. Connect MSG and SD terminals of the brake unit to a correct destination. Incorrect connection destination results in the resistance regeneration converter unit and brake unit malfunction.
 12. For connecting L+ and L- terminals of TE2-1 of the resistance regeneration converter unit to the terminal block, use the cable indicated in (4) in this section.
 13. Configure a circuit to turn off EM2 in the drive unit when the main circuit power is turned off to prevent an unexpected restart of the drive unit.
 14. The wiring is for MR-J4-DU_B_(-RJ). The connection for the interface of MR-J4-DU_(-RJ) is the same as in the case of MR-J4_(-RJ). Refer to each servo amplifier instruction manual.

8. OPTIONS AND PERIPHERAL EQUIPMENT

(2) When magnetic contactor drive output is disabled

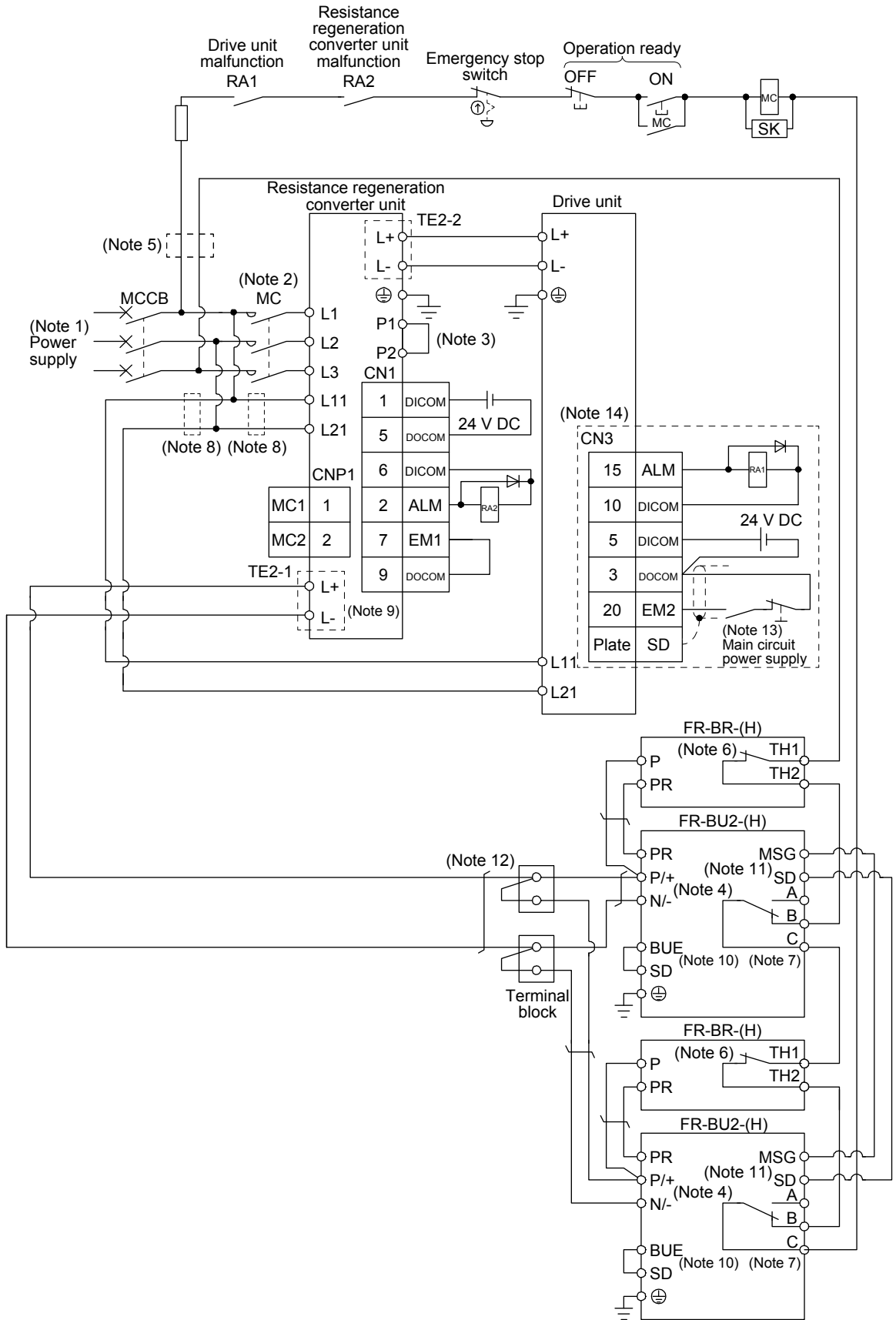

8. OPTIONS AND PERIPHERAL EQUIPMENT

- Note
1. For the power supply specifications, refer to section 1.4.
 2. Use a magnetic contactor with an operation delay time (interval between current being applied to the coil until closure of contacts) of 80 ms or less. Depending on the main circuit voltage and operation pattern, bus voltage decreases, and that may cause the forced stop deceleration to shift to the dynamic brake deceleration. When dynamic brake deceleration is not required, slow the time to turn off the magnetic contactor.
 3. P1 and P2 are connected by default. When using the power factor improving DC reactor, connect P1 and P2 after removing the short bar across them. Refer to section 8.6 for details.
 4. Connect P/+ and N/- terminals of the brake unit to a correct destination. Incorrect connection destination results in the resistance regeneration converter unit and brake unit malfunction.
 5. For 400 V class, a step-down transformer is required.
 6. Contact rating: 1b contact, 110 V AC, 5 A/220 V AC, 3 A
Normal condition: TH1-TH2 is conducting. Abnormal condition: TH1-TH2 is not conducting.
 7. Contact rating: 230 V AC, 0.3 A/30 V DC, 0.3 A
Normal condition: B-C is conducting./A-C is not conducting. Abnormal condition: B-C is not conducting./A-C is conducting.
 8. Install an overcurrent protection device (molded-case circuit breaker or fuse) to protect the branch circuit. (Refer to section 8.5.)
 9. Do not connect more than one cable to each L+ and L- terminals of TE2-1 of the resistance regeneration converter unit.
 10. Always connect BUE and SD terminals. (factory-wired)
 11. Connect MSG and SD terminals of the brake unit to a correct destination. Incorrect connection destination results in the resistance regeneration converter unit and brake unit malfunction.
 12. For connecting L+ and L- terminals of TE2-1 of the resistance regeneration converter unit to the terminal block, use the cable indicated in (4) in this section.
 13. Configure a circuit to turn off EM2 in the drive unit when the main circuit power is turned off to prevent an unexpected restart of the drive unit.
 14. The wiring is for MR-J4-DU_B_(-RJ). The connection for the interface of MR-J4-DU_(-RJ) is the same as in the case of MR-J4_(-RJ). Refer to each servo amplifier instruction manual.

8. OPTIONS AND PERIPHERAL EQUIPMENT

8.11.4 Combination with MT-BR5-(H) resistor unit

POINT

● Connecting PR terminal of the brake unit to L+ terminal of the resistance regeneration converter unit results in a brake unit malfunction. Always connect the PR terminal of the brake unit to the PR terminal of the resistor unit.

- (1) When connecting a brake unit to a resistance regeneration converter unit
 (a) When magnetic contactor drive output is enabled

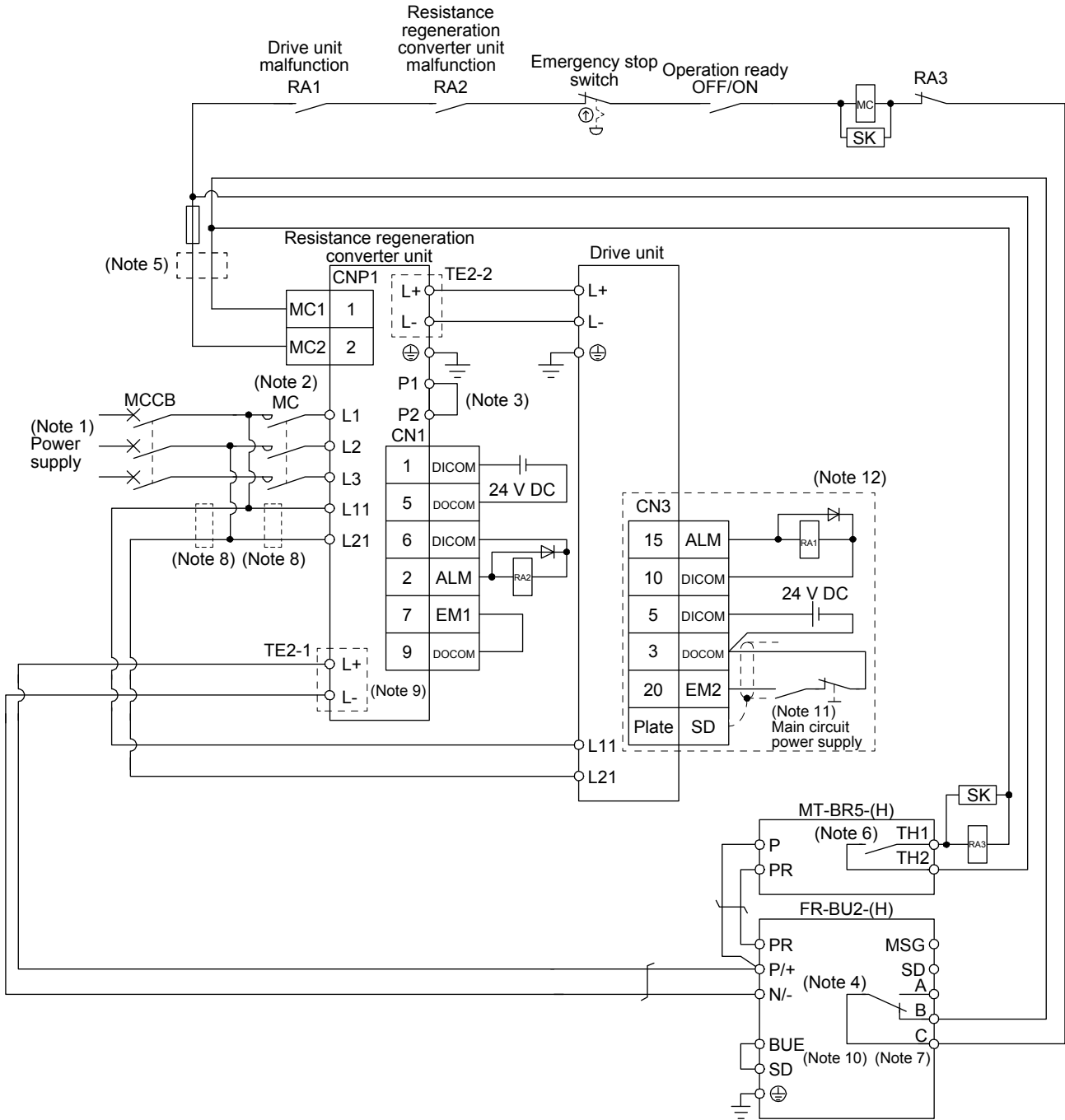

8. OPTIONS AND PERIPHERAL EQUIPMENT

- Note
1. For the power supply specifications, refer to section 1.4.
 2. Use a magnetic contactor with an operation delay time (interval between current being applied to the coil until closure of contacts) of 80 ms or less. Depending on the main circuit voltage and operation pattern, bus voltage decreases, and that may cause the forced stop deceleration to shift to the dynamic brake deceleration. When dynamic brake deceleration is not required, slow the time to turn off the magnetic contactor.
 3. P1 and P2 are connected by default. When using the power factor improving DC reactor, connect P1 and P2 after removing the short bar across them. Refer to section 8.6 for details.
 4. Connect P/+ and N/- terminals of the brake unit to a correct destination. Incorrect connection destination results in the resistance regeneration converter unit and brake unit malfunction.
 5. For 400 V class, a step-down transformer is required.
 6. Contact rating: 1a contact, 110 V AC, 5 A/220 V AC, 3 A
Normal condition: TH1-TH2 is not conducting. Abnormal condition: TH1-TH2 is conducting.
 7. Contact rating: 230 V AC, 0.3 A/30 V DC, 0.3 A
Normal condition: B-C is conducting./A-C is not conducting. Abnormal condition: B-C is not conducting./A-C is conducting.
 8. Install an overcurrent protection device (molded-case circuit breaker or fuse) to protect the branch circuit. (Refer to section 8.5.)
 9. Do not connect more than one cable to each L+ and L- terminals of TE2-1 of the resistance regeneration converter unit.
 10. Always connect BUE and SD terminals. (factory-wired)
 11. Configure a circuit to turn off EM2 in the drive unit when the main circuit power is turned off to prevent an unexpected restart of the drive unit.
 12. The wiring is for MR-J4-DU_B_(-RJ). The connection for the interface of MR-J4-DU_(-RJ) is the same as in the case of MR-J4_(-RJ). Refer to each servo amplifier instruction manual.

8. OPTIONS AND PERIPHERAL EQUIPMENT

(b) When magnetic contactor drive output is disabled

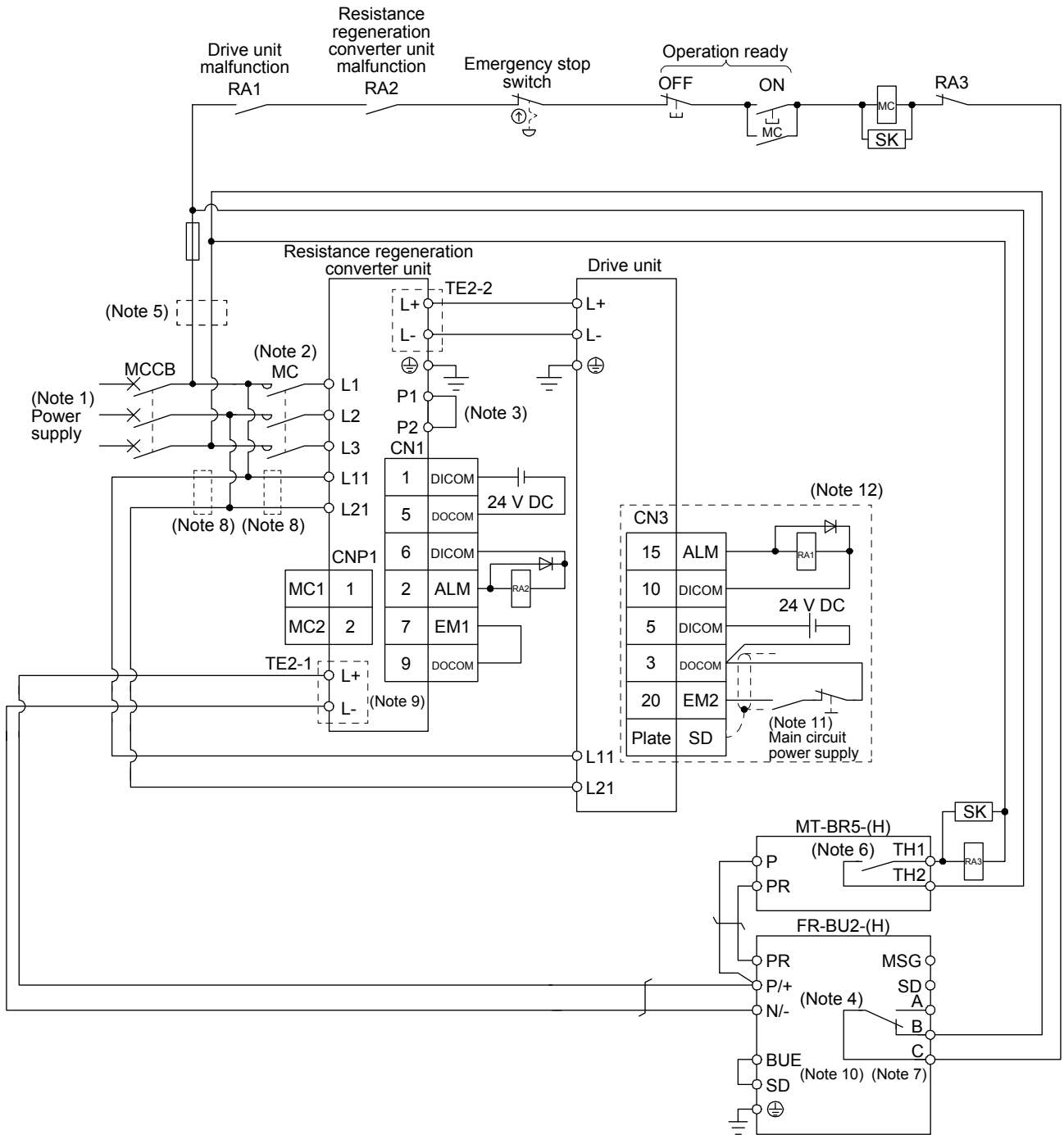

8. OPTIONS AND PERIPHERAL EQUIPMENT

- Note
1. For the power supply specifications, refer to section 1.4.
 2. Use a magnetic contactor with an operation delay time (interval between current being applied to the coil until closure of contacts) of 80 ms or less. Depending on the main circuit voltage and operation pattern, bus voltage decreases, and that may cause the forced stop deceleration to shift to the dynamic brake deceleration. When dynamic brake deceleration is not required, slow the time to turn off the magnetic contactor.
 3. P1 and P2 are connected by default. When using the power factor improving DC reactor, connect P1 and P2 after removing the short bar across them. Refer to section 8.6 for details.
 4. Connect P/+ and N/- terminals of the brake unit to a correct destination. Incorrect connection destination results in the resistance regeneration converter unit and brake unit malfunction.
 5. For 400 V class, a step-down transformer is required.
 6. Contact rating: 1a contact, 110 V AC, 5 A/220 V AC, 3 A
Normal condition: TH1-TH2 is not conducting. Abnormal condition: TH1-TH2 is conducting.
 7. Contact rating: 230 V AC, 0.3 A/30 V DC, 0.3 A
Normal condition: B-C is conducting./A-C is not conducting. Abnormal condition: B-C is not conducting./A-C is conducting.
 8. Install an overcurrent protection device (molded-case circuit breaker or fuse) to protect the branch circuit. (Refer to section 8.5.)
 9. Do not connect more than one cable to each L+ and L- terminals of TE2-1 of the resistance regeneration converter unit.
 10. Always connect BUE and SD terminals. (factory-wired)
 11. Configure a circuit to turn off EM2 in the drive unit when the main circuit power is turned off to prevent an unexpected restart of the drive unit.
 12. The wiring is for MR-J4-DU_B_(-RJ). The connection for the interface of MR-J4-DU_(-RJ) is the same as in the case of MR-J4_(-RJ). Refer to each servo amplifier instruction manual.

8. OPTIONS AND PERIPHERAL EQUIPMENT

(2) When connecting two brake units to a resistance regeneration converter unit

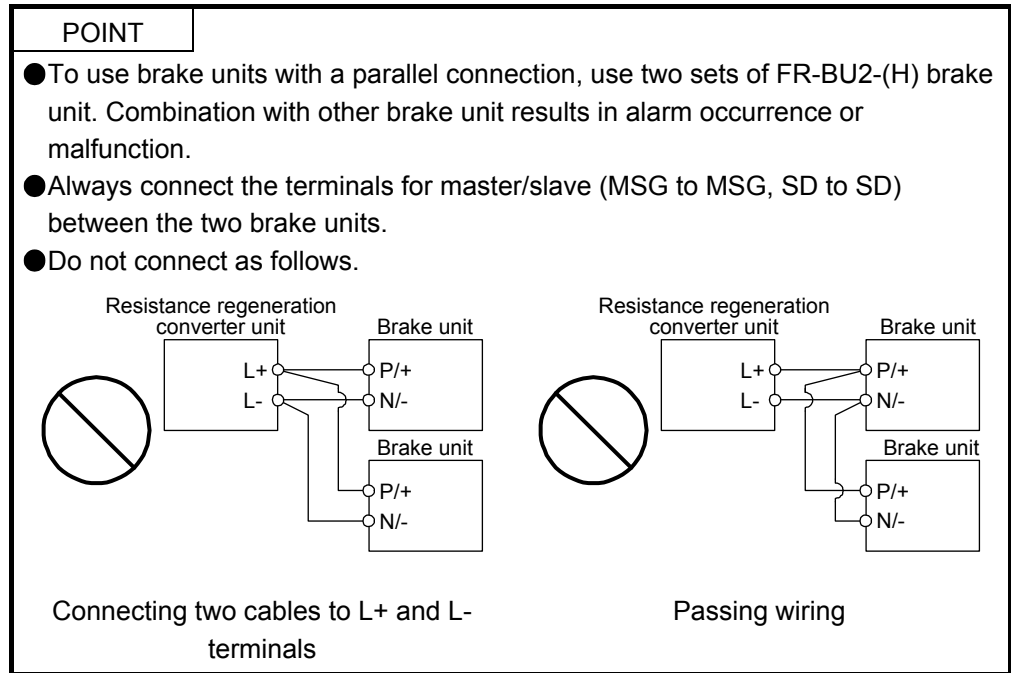

8. OPTIONS AND PERIPHERAL EQUIPMENT

(a) When magnetic contactor drive output is enabled

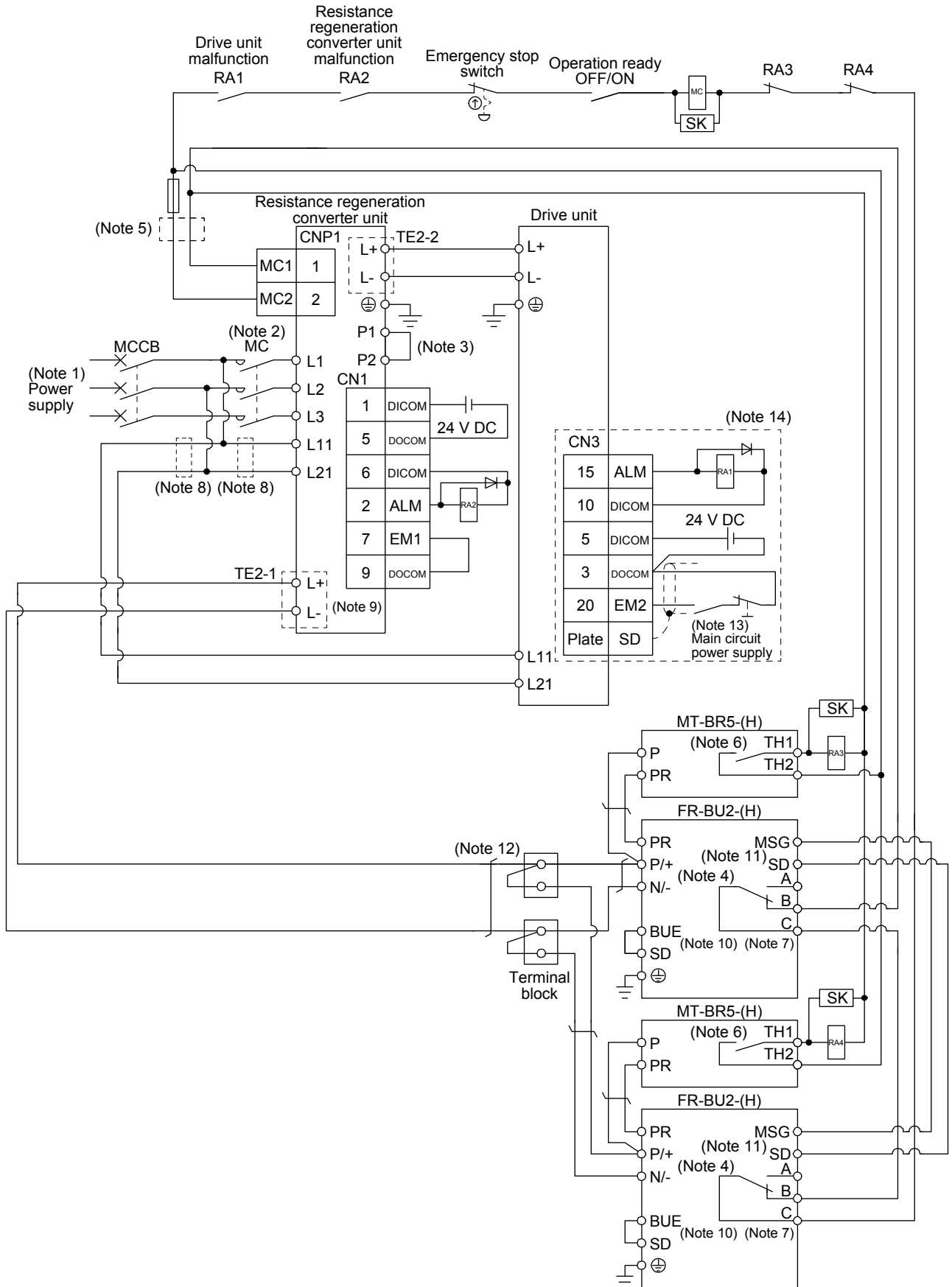

8. OPTIONS AND PERIPHERAL EQUIPMENT

- Note
1. For the power supply specifications, refer to section 1.4.
 2. Use a magnetic contactor with an operation delay time (interval between current being applied to the coil until closure of contacts) of 80 ms or less. Depending on the main circuit voltage and operation pattern, bus voltage decreases, and that may cause the forced stop deceleration to shift to the dynamic brake deceleration. When dynamic brake deceleration is not required, slow the time to turn off the magnetic contactor.
 3. P1 and P2 are connected by default. When using the power factor improving DC reactor, connect P1 and P2 after removing the short bar across them. Refer to section 8.6 for details.
 4. Connect P/+ and N/- terminals of the brake unit to a correct destination. Incorrect connection destination results in the resistance regeneration converter unit and brake unit malfunction.
 5. For 400 V class, a step-down transformer is required.
 6. Contact rating: 1a contact, 110 V AC, 5 A/220 V AC, 3 A
Normal condition: TH1-TH2 is not conducting. Abnormal condition: TH1-TH2 is conducting.
 7. Contact rating: 230 V AC, 0.3 A/30 V DC, 0.3 A
Normal condition: B-C is conducting./A-C is not conducting. Abnormal condition: B-C is not conducting./A-C is conducting.
 8. Install an overcurrent protection device (molded-case circuit breaker or fuse) to protect the branch circuit. (Refer to section 8.5.)
 9. Do not connect more than one cable to each L+ and L- terminals of TE2-1 of the resistance regeneration converter unit.
 10. Always connect BUE and SD terminals. (factory-wired)
 11. Connect MSG and SD terminals of the brake unit to a correct destination. Incorrect connection destination results in the resistance regeneration converter unit and brake unit malfunction.
 12. For connecting L+ and L- terminals of the resistance regeneration converter unit to the terminal block, use the cable indicated in (4) in this section.
 13. Configure a circuit to turn off EM2 in the drive unit when the main circuit power is turned off to prevent an unexpected restart of the drive unit.
 14. The wiring is for MR-J4-DU_B_(-RJ). The connection for the interface of MR-J4-DU_(-RJ) is the same as in the case of MR-J4_(-RJ). Refer to each servo amplifier instruction manual.

8. OPTIONS AND PERIPHERAL EQUIPMENT

(b) When magnetic contactor drive output is disabled

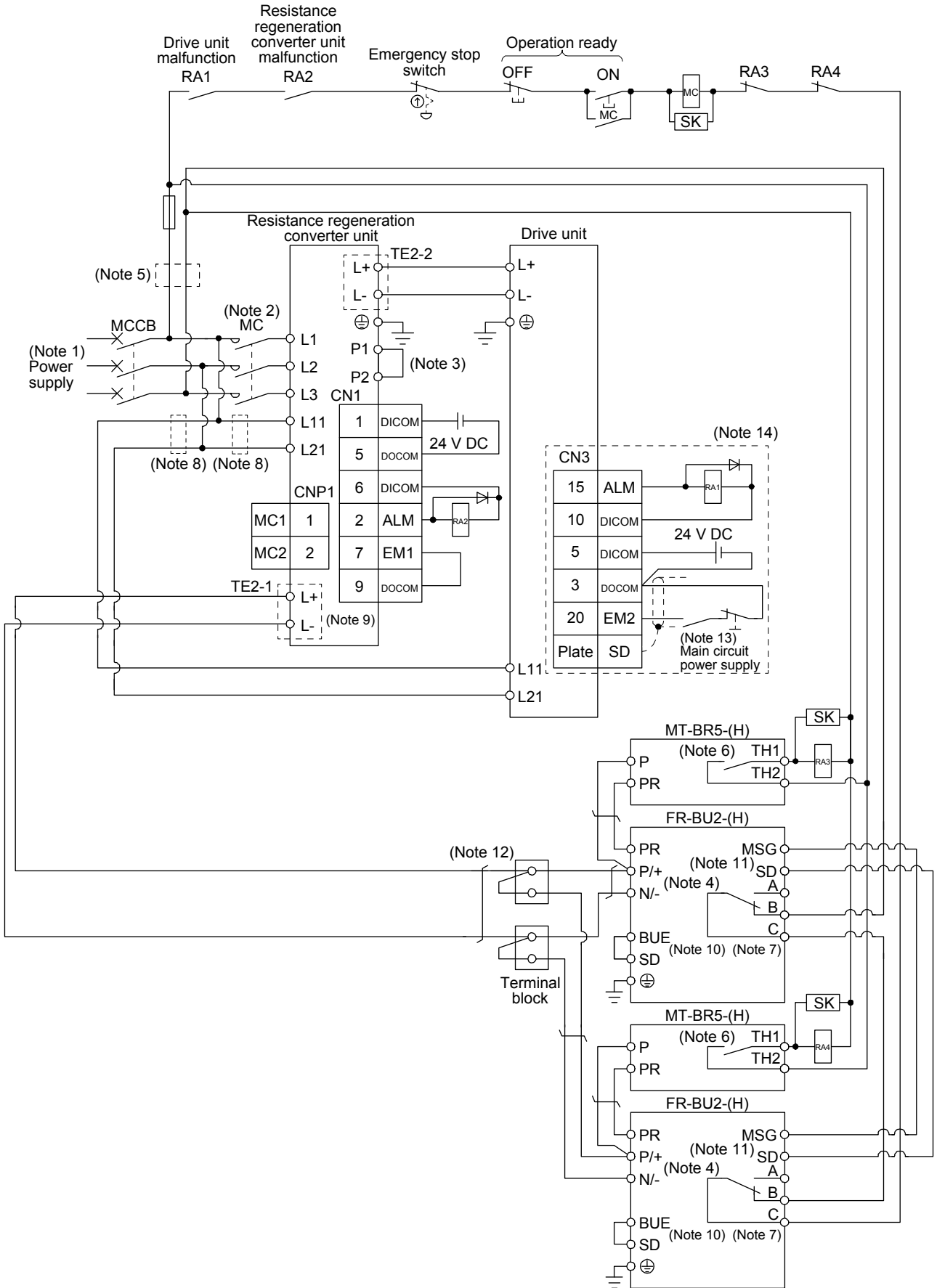

8. OPTIONS AND PERIPHERAL EQUIPMENT

- Note
- For the power supply specifications, refer to section 1.4.
 - Use a magnetic contactor with an operation delay time (interval between current being applied to the coil until closure of contacts) of 80 ms or less. Depending on the main circuit voltage and operation pattern, bus voltage decreases, and that may cause the forced stop deceleration to shift to the dynamic brake deceleration. When dynamic brake deceleration is not required, slow the time to turn off the magnetic contactor.
 - P1 and P2 are connected by default. When using the power factor improving DC reactor, connect P1 and P2 after removing the short bar across them. Refer to section 8.6 for details.
 - Connect P/+ and N/- terminals of the brake unit to a correct destination. Incorrect connection destination results in the resistance regeneration converter unit and brake unit malfunction.
 - For 400 V class, a step-down transformer is required.
 - Contact rating: 1a contact, 110 V AC, 5 A/220 V AC, 3 A
Normal condition: TH1-TH2 is not conducting. Abnormal condition: TH1-TH2 is conducting.
 - Contact rating: 230 V AC, 0.3 A/30 V DC, 0.3 A
Normal condition: B-C is conducting./A-C is not conducting. Abnormal condition: B-C is not conducting./A-C is conducting.
 - Install an overcurrent protection device (molded-case circuit breaker or fuse) to protect the branch circuit. (Refer to section 8.5.)
 - Do not connect more than one cable to each L+ and L- terminals of TE2-1 of the resistance regeneration converter unit.
 - Always connect BUE and SD terminals. (factory-wired)
 - Connect MSG and SD terminals of the brake unit to a correct destination. Incorrect connection destination results in the resistance regeneration converter unit and brake unit malfunction.
 - For connecting L+ and L- terminals of the resistance regeneration converter unit to the terminal block, use the cable indicated in (4) in this section.
 - Configure a circuit to turn off EM2 in the drive unit when the main circuit power is turned off to prevent an unexpected restart of the drive unit.
 - The wiring is for MR-J4-DU_B_(-RJ). The connection for the interface of MR-J4-DU_(-RJ) is the same as in the case of MR-J4_(-RJ). Refer to each servo amplifier instruction manual.

8.11.5 Connection instructions

Keep the wires between the resistance regeneration converter unit and the brake unit, and between the resistor unit and the brake unit as short as possible. For wires longer than 5 m, twist the wires five times or more per meter. The wires should not exceed 10 m even when the wires are twisted. If wires exceeding 5 m without twisted or exceeding 10 m with or without twisted are used, the brake unit may malfunction.

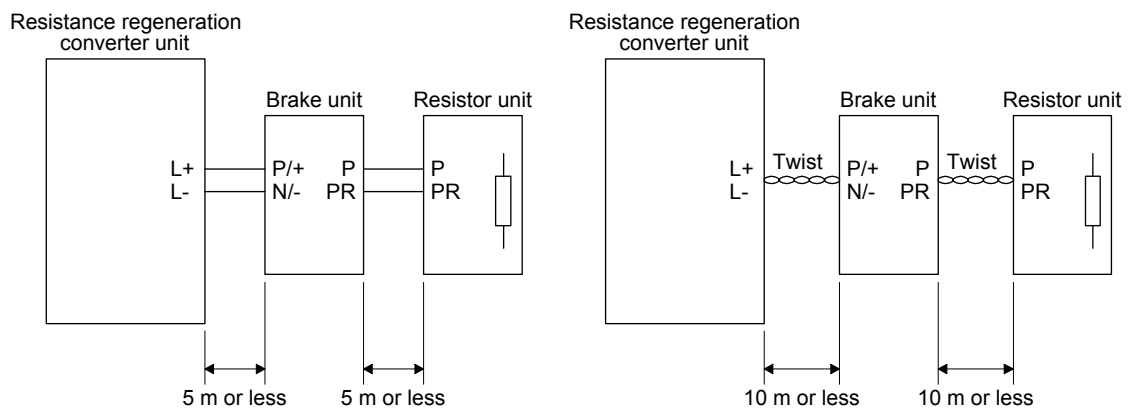

8. OPTIONS AND PERIPHERAL EQUIPMENT

8.11.6 Wires

(1) Wires for the brake unit

For the brake unit, HIV wire (600 V Grade heat-resistant polyvinyl chloride insulated wire) is recommended.

(a) Main circuit terminal

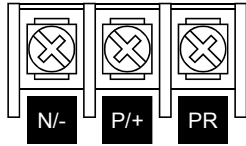

Terminal block

Brake unit		Main circuit terminal screw size	Crimp terminal N/-, P/+, PR,⊕	Tightening torque [N•m]	Wire size	
					N/-, P/+, PR,⊕	
					HIV wire [mm ²]	AWG
200 V class	FR-BU2-55K	M6	14-6	4.4	14	6
400 V class	FR-BU2-H55K	M5	5.5-5	2.5	5.5	10
	FR-BU2-H75K	M6	14-6	4.4	14	6

(b) Control circuit terminal

POINT
<ul style="list-style-type: none"> ● Under tightening can cause a cable disconnection or malfunction. Over tightening can cause a short circuit or malfunction due to damage to the screw or the brake unit.

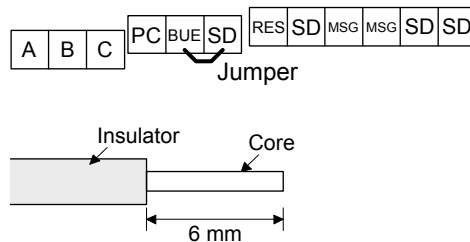

Wire the stripped cable after twisting to prevent the cable from becoming loose. In addition, do not solder it.

Screw size: M3

Tightening torque: 0.5 N•m to 0.6 N•m

Wire size: 0.3 mm² to 0.75 mm²

Screw driver: Small flat-blade screwdriver

(Tip thickness: 0.4 mm/Tip width 2.5 mm)

(2) Cables for connecting the resistance regeneration converter unit and a distribution terminal block when connecting two sets of the brake unit

Brake unit		Wire size	
		HIV wire [mm ²]	AWG
200 V class	FR-BU2-55K	38	2
400 V class	FR-BU2-H55K	14	6
	FR-BU2-H75K	38	2

8. OPTIONS AND PERIPHERAL EQUIPMENT

8.11.7 Crimp terminals for L+ and L- terminals of TE2-1 of resistance regeneration converter unit

(1) Recommended crimp terminals

POINT
<p>● Some crimp terminals may not be mounted depending on their sizes. Make sure to use the recommended ones or equivalent ones.</p>

Resistance regeneration converter unit		Brake unit	Number of connected units	Crimp terminal (Manufacturer)	(Note 1) Applicable tool
200 V class	MR-CR55K	FR-BU2-55K	2	38-S6 (JST) (Note 2) R38-6S (NICHIFU) (Note 2)	a
400 V class	MR-CR55K4	FR-BU2-H55K	2	FVD14-6 (JST)	b
		FR-BU2-H75K	2	38-S6 (JST) (Note 2) R38-6S (NICHIFU) (Note 2)	a

Note 1. Symbols in the applicable tool field indicate applicable tools in (5) (b) in this section.
 2. Coat the crimping part with an insulation tube.

(2) Applicable tool

Symbol	Resistance regeneration converter unit-side crimp terminal				
	Crimp terminal	Applicable tool			Manufacturer
		Body	Head	Dice	
a	38-S6	YPT-60-21	YET-60-1	TD-124	JST
		YF-1 E-4		TD-112	
	R38-6S	NOP60 NOM60			NICHIFU
b	FVD14-6	YF-1 E-4	YNE-38	DH-112 DH-122	JST

8. OPTIONS AND PERIPHERAL EQUIPMENT

8.11.8 Dimensions

- (1) FR-BU2-(H) brake unit
FR-BU2-55K/FR-BU2-H55K/FR-BU2-H75K

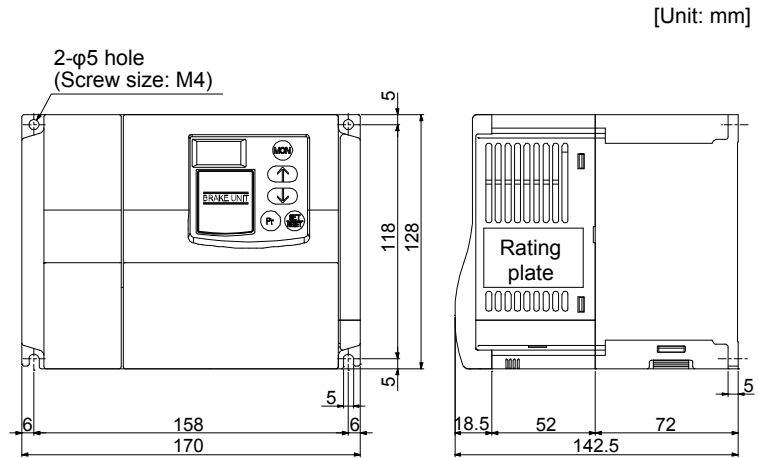

- (2) FR-BR-(H) resistor unit

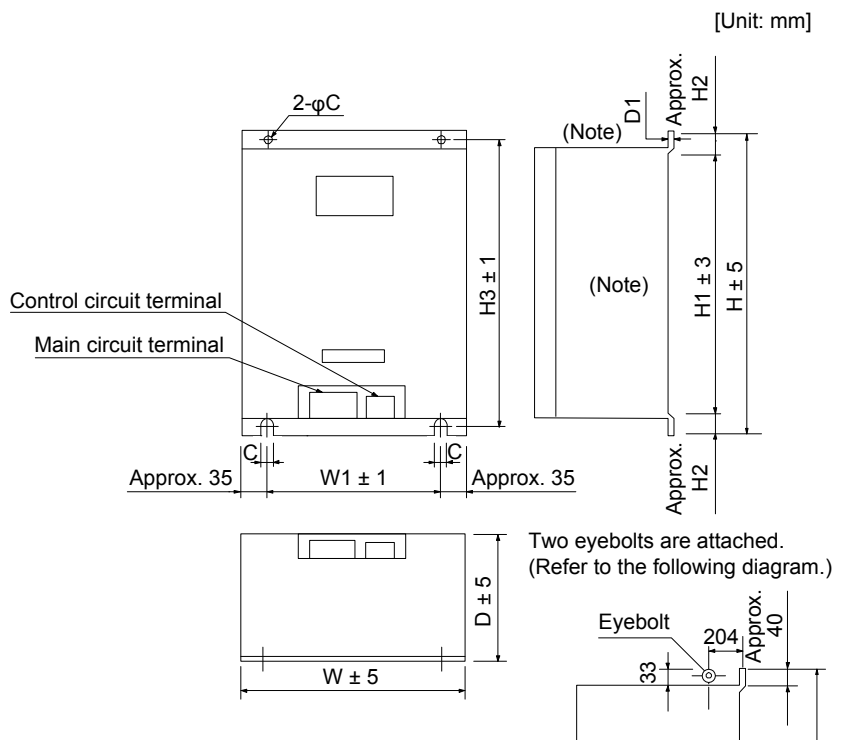

Note. Ventilation ports are provided on both sides and the top. The bottom is open.

Resistor unit		W	W1	H	H1	H2	H3	D	D1	C	Approximate mass [kg]
200 V class	FR-BR-55K	480	410	700	620	40	670	450	3.2	12	70
400 V class	FR-BR-H55K	480	410	700	620	20	670	450	3.2	12	70

8. OPTIONS AND PERIPHERAL EQUIPMENT

(3) MT-BR5-(H) resistor unit

[Unit: mm]

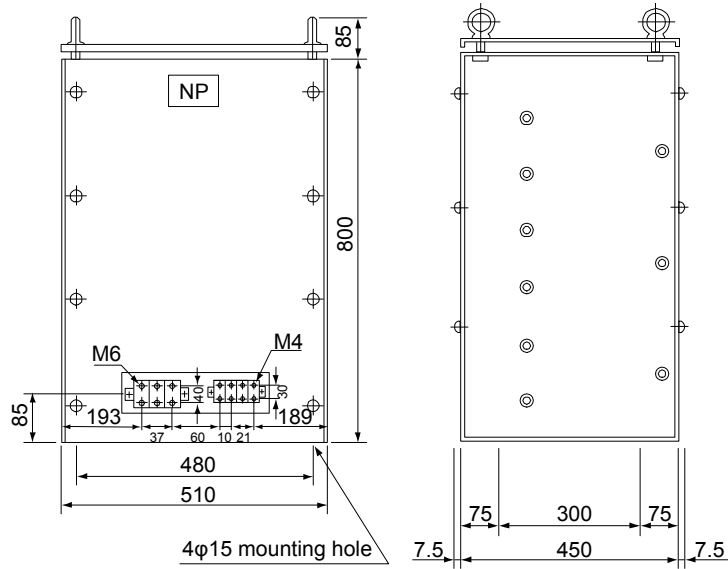

Resistor unit		Resistance	Approximate mass [kg]
200 V class	MT-BR5-55K	2.0 Ω	50
400 V class	MT-BR5-H75K	6.5 Ω	70

8. OPTIONS AND PERIPHERAL EQUIPMENT

8.12 MR-DCBAR_ bus bar

When one drive unit is connected to one power regeneration converter unit, the drive unit is driven at the rated output with the following combinations.

Use the bus bars for the connection of the L+/L- terminals between the converter unit and the drive unit, and between the drive units. The bus bars vary depending on the units to be connected. Be sure to use the bus bars listed in this section.

8.12.1 Bus bar

(1) 200 V class

Unit mounted on the left side (Note 1)	Unit mounted on the right side (Note 1)	Bus bar model	Number contained in a set
MR-CR55K	MR-J4-DU30K_(-RJ)/MR-J4-DU37K_(-RJ)	MR-DCBAR106-C04 (Note 2)	2
MR-CV11K	MR-J4-DU900B(-RJ)/MR-J4-DU11KB(-RJ)	MR-DCBAR137-B52	1 (assembled)
MR-CV18K	MR-J4-DU900B(-RJ)/MR-J4-DU11KB(-RJ)	MR-DCBAR137-B52	1 (assembled)
	MR-J4-DU15KB(-RJ)	MR-DCBAR235-B52	1 (assembled)
MR-CV30K	MR-J4-DU900B(-RJ)/MR-J4-DU11KB(-RJ)	MR-DCBAR159-B52	1 (assembled)
	MR-J4-DU15KB(-RJ)/MR-J4-DU22KB(-RJ)	MR-DCBAR255-B52	1 (assembled)
	MR-J4-DU30KB(-RJ)	MR-DCBAR105-C03	2
MR-CV37K MR-CV45K	MR-J4-DU900B(-RJ)/MR-J4-DU11KB(-RJ)	MR-DCBAR159-B52	1 (assembled)
	MR-J4-DU15KB(-RJ)/MR-J4-DU22KB(-RJ)	MR-DCBAR255-B52	1 (assembled)
	MR-J4-DU30KB(-RJ)/MR-J4-DU37KB(-RJ)	MR-DCBAR105-C03	2
MR-CV55K	MR-J4-DU900B(-RJ)/MR-J4-DU11KB(-RJ)	MR-DCBAR159-B53	1 (assembled)
	MR-J4-DU15KB(-RJ)/MR-J4-DU22KB(-RJ)	MR-DCBAR257-B53	1 (assembled)
	MR-J4-DU30KB(-RJ)/MR-J4-DU37KB(-RJ)	MR-DCBAR106-C04 (Note 2)	2
MR-J4-DU900B	MR-J4-DU900B(-RJ)	MR-DCBAR170-B52	1 (assembled)
MR-J4-DU11KB	MR-J4-DU900B(-RJ)/MR-J4-DU11KB(-RJ)	MR-DCBAR170-B52	1 (assembled)
MR-J4-DU15KB	MR-J4-DU900B(-RJ)/MR-J4-DU11KB(-RJ)	MR-DCBAR137-B52	1 (assembled)
	MR-J4-DU15KB(-RJ)	MR-DCBAR235-B52	1 (assembled)
MR-J4-DU22KB	MR-J4-DU900B(-RJ)/MR-J4-DU11KB(-RJ)	MR-DCBAR137-B52	1 (assembled)
	MR-J4-DU15KB(-RJ)/MR-J4-DU22KB(-RJ)	MR-DCBAR235-B52	1 (assembled)
MR-J4-DU30KB	MR-J4-DU900B(-RJ)/MR-J4-DU11KB(-RJ)	MR-DCBAR159-B53	1 (assembled)
	MR-J4-DU15KB(-RJ)/MR-J4-DU22KB(-RJ)	MR-DCBAR257-B53	1 (assembled)
	MR-J4-DU30KB(-RJ)	MR-DCBAR106-C04 (Note 2)	2
MR-J4-DU37KB	MR-J4-DU900B(-RJ)/MR-J4-DU11KB(-RJ)	MR-DCBAR159-B53	1 (assembled)
	MR-J4-DU15KB(-RJ)/MR-J4-DU22KB(-RJ)	MR-DCBAR257-B53	1 (assembled)
	MR-J4-DU30KB(-RJ)/MR-J4-DU37KB(-RJ)	MR-DCBAR106-C04 (Note 2)	2

- Note 1. "Unit mounted on the left side" and "Unit mounted on the right side" indicate the position when the units are seen from the front. Install the power regeneration converter unit on the left side of the drive unit.
2. This is supplied with the drive unit.

8. OPTIONS AND PERIPHERAL EQUIPMENT

(2) 400 V class

Unit mounted on the left side (Note 1)	Unit mounted on the right side (Note 1)	Bus bar model	Number contained in a set
MR-CR55K4	MR-J4-DU30K_4(-RJ)/MR-J4-DU37K_4(-RJ)	MR-DCBAR085-C03 (Note 2)	2
	MR-J4-DU45K_4(-RJ)/MR-J4-DU55K_4(-RJ)	MR-DCBAR106-C04 (Note 2)	2
MR-CV11K4	MR-J4-DU900B4(-RJ)/MR-J4-DU11KB4(-RJ)	MR-DCBAR137-B52	1 (assembled)
MR-CV18K4	MR-J4-DU900B4(-RJ)/MR-J4-DU11KB4(-RJ)	MR-DCBAR137-B52	1 (assembled)
	Model MR-J4-DU_(-RJ)	MR-DCBAR235-B52	1 (assembled)
MR-CV30K4	MR-J4-DU900B4(-RJ)/MR-J4-DU11KB4(-RJ)	MR-DCBAR159-B52	1 (assembled)
	MR-J4-DU15KB4(-RJ)/MR-J4-DU22KB4(-RJ)	MR-DCBAR255-B52	1 (assembled)
	MR-J4-DU30KB4(-RJ)	MR-DCBAR082-C02	2
MR-CV37K4	MR-J4-DU900B4(-RJ)/MR-J4-DU11KB4(-RJ)	MR-DCBAR159-B52	1 (assembled)
	MR-J4-DU15KB4(-RJ)/MR-J4-DU22KB4(-RJ)	MR-DCBAR255-B52	1 (assembled)
	MR-J4-DU30KB4(-RJ)/MR-J4-DU37KB4(-RJ)	MR-DCBAR082-C02	2
MR-CV45K4	MR-J4-DU900B4(-RJ)/MR-J4-DU11KB4(-RJ)	MR-DCBAR159-B52	1 (assembled)
	MR-J4-DU15KB4(-RJ)/MR-J4-DU22KB4(-RJ)	MR-DCBAR255-B52	1 (assembled)
	MR-J4-DU30KB4(-RJ)/MR-J4-DU37KB4(-RJ)	MR-DCBAR082-C02	2
	MR-J4-DU45KB4(-RJ)	MR-DCBAR105-C03	2
MR-CV55K4 MR-CV75K4	MR-J4-DU900B4(-RJ)/MR-J4-DU11KB4(-RJ)	MR-DCBAR159-B53	1 (assembled)
	MR-J4-DU15KB4(-RJ)/MR-J4-DU22KB4(-RJ)	MR-DCBAR257-B53	1 (assembled)
	MR-J4-DU30KB4(-RJ)/MR-J4-DU37KB4(-RJ)	MR-DCBAR085-C03 (Note 2)	2
	MR-J4-DU45KB4(-RJ)/MR-J4-DU55KB4(-RJ)	MR-DCBAR106-C04 (Note 2)	2
MR-J4-DU900B4	MR-J4-DU900B4(-RJ)	MR-DCBAR170-B52	1 (assembled)
MR-J4-DU11KB4	MR-J4-DU900B4(-RJ)/MR-J4-DU11KB4(-RJ)	MR-DCBAR170-B52	1 (assembled)
MR-J4-DU15KB4	MR-J4-DU900B4(-RJ)/MR-J4-DU11KB4(-RJ)	MR-DCBAR137-B52	1 (assembled)
	MR-J4-DU15KB4(-RJ)	MR-DCBAR235-B52	1 (assembled)
MR-J4-DU22KB4	MR-J4-DU900B4(-RJ)/MR-J4-DU11KB4(-RJ)	MR-DCBAR137-B52	1 (assembled)
	MR-J4-DU15KB4(-RJ)/MR-J4-DU22KB4(-RJ)	MR-DCBAR235-B52	1 (assembled)
MR-J4-DU30KB4	MR-J4-DU900B4(-RJ)/MR-J4-DU11KB4(-RJ)	MR-DCBAR310-B52	1 (assembled)
	MR-J4-DU15KB4(-RJ)/MR-J4-DU22KB4(-RJ)	MR-DCBAR409-B52	1 (assembled)
	MR-J4-DU30KB4(-RJ)	MR-DCBAR235-B52	1 (assembled)
MR-J4-DU37KB4	MR-J4-DU900B4(-RJ)/MR-J4-DU11KB4(-RJ)	MR-DCBAR310-B52	1 (assembled)
	MR-J4-DU15KB4(-RJ)/MR-J4-DU22KB4(-RJ)	MR-DCBAR409-B52	1 (assembled)
	MR-J4-DU30KB4(-RJ)/MR-J4-DU37KB4(-RJ)	MR-DCBAR235-B52	1 (assembled)

8. OPTIONS AND PERIPHERAL EQUIPMENT

Unit mounted on the left side (Note 1)	Unit mounted on the right side (Note 1)	Bus bar model	Number contained in a set
MR-J4-DU45KB4	MR-J4-DU900B4(-RJ)/MR-J4-DU11KB4(-RJ)	MR-DCBAR159-B53	1 (assembled)
	MR-J4-DU15KB4(-RJ)/MR-J4-DU22KB4(-RJ)	MR-DCBAR257-B53	1 (assembled)
	MR-J4-DU30KB4(-RJ)/MR-J4-DU37KB4(-RJ)	MR-DCBAR085-C03 (Note 2)	2
	MR-J4-DU45KB4(-RJ)	MR-DCBAR106-C04 (Note 2)	2
MR-J4-DU55KB4	MR-J4-DU900B4(-RJ)/MR-J4-DU11KB4(-RJ)	MR-DCBAR159-B53	1 (assembled)
	MR-J4-DU15KB4(-RJ)/MR-J4-DU22KB4(-RJ)	MR-DCBAR257-B53	1 (assembled)
	MR-J4-DU30KB4(-RJ)/MR-J4-DU37KB4(-RJ)	MR-DCBAR085-C03 (Note 2)	2
	MR-J4-DU45KB4(-RJ)/MR-J4-DU55KB4(-RJ)	MR-DCBAR106-C04 (Note 2)	2

- Note 1. "Unit mounted on the left side" and "Unit mounted on the right side" indicate the position when the units are seen from the front. Install the power regeneration converter unit on the left side of the drive unit.
2. This is supplied with the drive unit.

8.12.2 Adjustment bar

When the total number of MR-J4-DU900(4)(-RJ) and MR-J4-DU11KB(4)(-RJ) drive units connected to the power regeneration convert unit is even, there is a gap of bar thickness between the bus bar and TE2 terminal block of the final drive unit (right end). Place adjustment bars in the gap and screw them together. (Refer to section 3.3.1 (3).)

Bus bar	Number contained
MR-DCBAR035-B05	2

9. COMPLIANCE WITH SEMI-F47 STANDARD

9. COMPLIANCE WITH SEMI-F47 STANDARD

POINT
<ul style="list-style-type: none">● A combination of the MR-CV_ power regeneration converter unit and drive unit does not comply with SEMI-F47 standard.● The control circuit power supply of the resistance regeneration converter unit and drive unit can comply with SEMI-F47 standard. However, a back-up capacitor may be necessary for instantaneous power failure in the main circuit power supply depending on the power impedance and operating situation.● The external dynamic brake cannot be used for compliance with SEMI-F47 standard. Do not assign DB (Dynamic brake interlock). Doing so will cause the drive unit to become servo-off when an instantaneous power failure occurs.● Be sure to perform actual machine tests and detail checks for power supply instantaneous power failure of SEMI-F47 standard with your equipment.

The following explains the compliance with "SEMI-F47 semiconductor process equipment voltage sag immunity test" of MR-J4 series.

This function enables to avoid triggering [AL. 10 Undervoltage] using the electrical energy charged in the capacitor in case that an instantaneous power failure occurs during operation.

9. COMPLIANCE WITH SEMI-F47 STANDARD

9.1 Parameter setting

Setting parameters of the drive unit and resistance regeneration converter unit as follows will enable SEMI-F47 function.

Parameter	Setting value	Description
[Pr. PA20] of the drive unit	_ 1 _ _	SEMI-F47 function selection
[Pr. PF25] of the drive unit	200	Set the time [ms] until the occurrence of [AL. 10.1 Voltage drop in the control circuit power].
[Pr. PA17] of the resistance regeneration converter unit	_ _ 1 _	SEMI-F47 function selection
[Pr. PA18] of the resistance regeneration converter unit	200	Set the time [ms] until the occurrence of [AL. 10 Undervoltage].

Enabling SEMI-F47 function will change operation as follows.

- (1) The voltage will drop in the control circuit power at "Rated voltage × 50% or less". After 200 ms, [AL. 10.1 Voltage drop in the control circuit power] will occur.
- (2) [AL. 10.2 Voltage drop in the main circuit power] will occur when bus voltage is as follows.

Voltages which trigger [AL. 10.2 Voltage drop in the main circuit power]

Drive unit	Bus voltage which triggers alarm
MR-J4-DU30KB(-RJ) MR-J4-DU30KA(-RJ) MR-J4-DU37KB(-RJ) MR-J4-DU37KA(-RJ)	200 V DC
MR-J4-DU30KB4(-RJ) MR-J4-DU30KA4(-RJ) MR-J4-DU37KB4(-RJ) MR-J4-DU37KA4(-RJ) MR-J4-DU45KB4(-RJ) MR-J4-DU45KA4(-RJ) MR-J4-DU55KB4(-RJ) MR-J4-DU55KA4(-RJ)	380 V DC

- (3) MBR (Electromagnetic brake interlock) will turn off when [AL. 10.1 Voltage drop in the control circuit power] occurs.

9. COMPLIANCE WITH SEMI-F47 STANDARD

9.2 Requirement of SEMI-F47 standard

The following shows the permissible time of instantaneous power failure for instantaneous power failure voltage of SEMI-F47 standard.

Requirement of SEMI-F47 standard

Instantaneous power failure voltage	Permissible time of instantaneous power failure [s]
Rated voltage × 80%	1
Rated voltage × 70%	0.5
Rated voltage × 50%	0.2

9.3 Calculation of tolerance against instantaneous power failure

The following shows tolerance against instantaneous power failure when instantaneous power failure voltage is "rated voltage × 50%" and instantaneous power failure time is 200 ms.

Tolerance against instantaneous power failure (instantaneous power failure voltage = rated voltage × 50%, instantaneous power failure time = 200 ms)

Drive unit model	Instantaneous maximum output [W]	Tolerance against instantaneous power failure [W] (voltage drop between lines)
MR-J4-DU30K_	79000	7500
MR-J4-DU37K_	103000	10000
MR-J4-DU30K_4	79000	7500
MR-J4-DU37K_4	103000	7500
MR-J4-DU45K_4	110000	7500
MR-J4-DU55K_4	135000	7500

Instantaneous maximum output means power which drive unit can output in maximum torque at rated speed. You can examine margins to compare the values of following conditions and instantaneous maximum output.

Even if driving at maximum torque with low speed in actual operation, the motor will not drive with the maximum output. This can be handled as a margin.

The following shows the conditions of tolerance against instantaneous power failure.

9.3.1 Delta connection

For the 3-phase (L1/L2/L3) delta connection, an instantaneous power failure occurs in the voltage between a pair of lines (e.g. between L1 and L2) among voltages between three pairs of lines (between L1 and L2, L2 and L3, or L3 and L1).

9.3.2 Star connection

For the 3-phase (L1/L2/L3/neutral point N) star connection, an instantaneous power failure occurs in the voltage between a pair of lines (e.g. between L1 and N) among voltages at six locations, between three pairs of lines (between L1 and L2, L2 and L3, or L3 and L1) and between one of the lines and the neutral point (between L1 and N, L2 and N, or L3 and N).

10. APPENDIX

10. APPENDIX

10.1 Peripheral equipment manufacturer (for reference)

Names given in the table are as of Jun. 2018.

Manufacturer	Contact information
DDK	DDK Ltd.
Phoenix Contact	Phoenix Contact GmbH & Co. KG
JST	J.S.T. Mfg. Co., Ltd.
Honda Tsushin Kogyo	HONDA TSUSHIN KOGYO CO., LTD.
3M	3M
NICHIFU	NICHIFU CO., LTD.
Soshin Electric	Soshin Electric Co., Ltd.
Okaya Electric Industries	OKAYA ELECTRIC INDUSTRIES CO., LTD.

10.2 Compliance with global standards

Converter units and drive units are written as servo amplifiers in app. 2 under certain circumstances.

10.2.1 Terms related to safety

(1) IEC 61800-5-2 Stop function

STO function (Refer to IEC 61800-5-2: 2007 4.2.2.2 STO.)

MR-J4 servo amplifiers have the STO function. The STO function shuts down energy to servo motors, thus removing torque. This function electronically cuts off power supply in the servo amplifier.

10.2.2 About safety

This chapter explains safety of users and machine operators.

(1) Professional engineer

Only professional engineers should mount MR-J4 servo amplifiers.

Here, professional engineers should meet all the conditions below.

(a) Persons who took a proper training of related work of electrical equipment or persons who can avoid risk based on past experience.

(b) Persons who have read and familiarized himself/herself with this installation guide and operating manuals for the protective devices (e.g. light curtain) connected to the safety control system.

(2) Applications of the devices

MR-J4 servo amplifiers comply with the following standards.

ISO/EN ISO 13849-1 Category 3 PL e, IEC/EN 62061 SIL CL 3, IEC/EN 61800-5-2 (STO), IEC/EN 61800-5-1, IEC/EN 61800-3, IEC/EN 60204-1

MR-J4 servo amplifiers can be used with the MR-J3-D05 safety logic unit, or safety PLCs.

10. APPENDIX

(3) Correct use

Use the MR-J4 servo amplifiers within specifications. Refer to section 1.4 for specifications such as voltage, temperature, etc. Mitsubishi Electric Co. accepts no claims for liability if the equipment is used in any other way or if modifications are made to the device, even in the context of mounting and installation.

 WARNING	<ul style="list-style-type: none"> ● If you need to get close to the moving parts of the machine for inspection or others, ensure safety by confirming the power off, etc. Otherwise, it may cause an accident. ● It takes 20 minutes maximum for capacitor discharging. Do not touch the unit and terminals immediately after power off.
--	---

(a) Selection of peripheral equipment and wire

The followings are selected based on IEC/EN 61800-5-1, UL 508C, and CSA C22.2 No. 14.

1) Local wiring

The following table shows the stranded wire sizes [AWG] and the crimp terminal symbols rated at 75 °C/60 °C.

Table App. 1 Recommended wire

Converter unit	75 °C/60 °C stranded wire [AWG] (Note 2)		
	L1/L2/L3 ⊕ (Note 3)	L11/L21	L+/L-
MR-CV11K (Note 1)	8: h/6: i	14: g/14: g	Exclusive Bus Bar
MR-CV18K (Note 1)	4: q/2: -		
MR-CV30K (Note 1)	2: n/1/0: j		
MR-CV37K (Note 1)	1/0: j/1/0: j		
MR-CV45K (Note 1)	1/0: j/-: -		
MR-CV55K (Note 1)	3/0: k/-: -		
MR-CV11K4 (Note 1)	10: l/10: l		
MR-CV18K4 (Note 1)	8: h/6: i		
MR-CV30K4 (Note 1)	6: m/4: e		
MR-CV37K4 (Note 1)	4: e/2: n		
MR-CV45K4 (Note 1)	4: e/2: n		
MR-CV55K4 (Note 1)	2: n/1/0: -		
MR-CV75K4 (Note 1)	1/0: j/-: -		
MR-CR55K (Note 1)	2 × 2/0: d (Note 4)/2 × 2/0: -		
MR-CR55K4 (Note 1)	2: c/1/0: -		

10. APPENDIX

Drive unit	75 °C/60 °C stranded wire [AWG] (Note 2)		
	L11/L21	L+/L-	U/V/W/⊕ (Note 3)
MR-J4-DU700 (Noe 1)	14: g/14: g	Exclusive Bus Bar	8: o/6: m
MR-J4-DU900 (Note 1)			4: e/2: n
MR-J4-DU11K (Note 1)			4: e/2: n
MR-J4-DU15K (Note 1)			2: n/1/0: j
MR-J4-DU22K (Note 1)			1/0: j/-: -
MR-J4-DU30K (Note 1)			2/0: d/2/0: -
MR-J4-DU37K (Note 1)			2 × 2/0: d (Note 4)/-: -
MR-J4-DU700_4 (Note 1)			10: p/10: p
MR-J4-DU900_4 (Note 1)			8: o/6: m
MR-J4-DU11K_4 (Note 1)			8: o/6: m
MR-J4-DU15K_4 (Note 1)			6: m/6: m
MR-J4-DU22K_4 (Note 1)			4: e/2: n
MR-J4-DU30K_4 (Note 1)			3: f/2: f
MR-J4-DU37K_4 (Note 1)			2: f/1: c
MR-J4-DU45K_4 (Note 1)			1/0: d/1/0: -
MR-J4-DU55K_4 (Note 1)			1/0: d/2/0: -

- Note 1. To connect these models to a terminal block, be sure to use the screws that come with the terminal block.
2. Alphabets in the table indicate crimping tools. For crimp terminals and applicable tools, refer to (3) (a) 3) in this section.
3. Select wire sizes depending on the rated output of the servo motors. The values in the table are sizes based on rated output of the servo amplifiers.
4. When the rated current is less than 175 A, 2/0: d can also be used.

2) Crimping tool

Symbol	Servo amplifier-side crimp terminals		Manufacturer
	Crimp terminal (Note 2)	Applicable tool	
a	FVD5.5-10	YNT-1210S	JST (J.S.T. Mfg. Co., Ltd.)
b	FVD22-10	YF-1/E-4	
c (Note 1)	R38-10	YPT-60-21	
		YF-1/E-4	
d (Note 1)	R60-10	YPT-60-21	
		YF-1/E-4	
e	FVD22-8	YF-1/E-4	
f (Note 1)	R38-8	YPT-60-21	
		YF-1/E-4	
g	FVD2-4	YNT-1614	
h	FVD8-5	YF-1/E-4	
i	FVD14-5	YF-1/E-4	
j (Note 1)	60-S8	YF-1/E-4	
k (Note 1)	80-10	YF-1/E-4	
l	FVD5.5-5	YNT-1210S	
m	FVD14-8	YF-1/E-4	
n	FVD38-8	YF-1/E-4	
o	FVD8-8	YF-1/E-4	
p	FVD5.5-8	YNT-1210S	
q (Note 1)	22-S5	YF-1/E-4	

- Note 1. Coat the crimping part with an insulation tube.
2. Some crimp terminals may not be mounted depending on their sizes. Make sure to use the recommended ones or equivalent ones.

10. APPENDIX

3) Selection example of MCCB and fuse

Use a fuse (T class) or the molded-case circuit breaker (UL 489 Listed MCCB) indicated in the table below. The T class fuses and molded-case circuit breakers in the table are selected examples based on rated I/O of the servo amplifiers. When you select a smaller capacity servo motor to connect it to the servo amplifier, you can also use smaller capacity T class fuses or molded-case circuit breaker than ones in the table. For selecting ones other than Class T fuses and molded-case circuit breakers below, refer to section 1.4.

Converter unit	Molded-case circuit breaker (240 V AC)	Fuse (300 V)
MR-CV11K	NF100-CVFU-60A (100 A frame 60 A)	80 A
MR-CV18K	NF100-CVFU-100A (100 A frame 100 A)	150 A
MR-CV30K	NF225-CVFU-150A (225 A frame 150 A)	225 A
MR-CV37K	NF225-CVFU-200A (225 A frame 200 A)	300 A
MR-CV45K	NF225-CWU-225A (225 A frame 225 A)	350 A
MR-CV55K	NF400-SKW-300A (400 A frame 300 A)	400 A
MR-CR55K	NF225-CWU-175A (225 A frame 175 A)	300 A

Converter unit	Molded-case circuit breaker (480 V AC)	Fuse (600 V)
MR-CV11K4	NF100-HRU-30A (100 A frame 30 A)	40 A
MR-CV18K4	NF100-HRU-50A (100 A frame 50 A)	80 A
MR-CV30K4	NF100-HRU-80A (100 A frame 80 A)	150 A
MR-CV37K4	NF100-HRU-100A (100 A frame 100 A)	150 A
MR-CV45K4	NF250-SVU-125A (250 A frame 125 A)	200 A
MR-CV55K4	NF250-SVU-150A (250 A frame 150 A)	225 A
MR-CV75K4	NF250-SVU-200A (250 A frame 200 A)	300 A
MR-CR55K4	NF125-SVU-125A (125 A frame 125 A)	200 A

4) Power supply

This servo amplifier can be used on the condition of overvoltage category III set forth in IEC/EN 60664-1. For the interface power supply, use an external 24 V DC power supply with reinforced insulation on I/O terminals.

5) Grounding

To prevent an electric shock, always connect the protective earth (PE) terminal (marked \oplus) of the servo amplifier to the protective earth (PE) of the cabinet. Do not connect two grounding cables to the same protective earth (PE) terminal. Always connect cables to the terminals one-to-one.

This product can cause a DC current in the protective earthing conductor. Where a residual current-operated protective (RCD: earth-leakage current breaker) device is used for protection in case of direct or indirect contact, only an RCD of Type B is allowed on the supply side of this product.



10. APPENDIX

(b) EU compliance

The EC directives were issued to standardize the regulations of the EU countries and ensure smooth distribution of safety-guaranteed products. The CE marking proves the compliance of the manufacturer with the EC directives, and this marking also applies to machines and equipment incorporating servos.

1) EMC requirement

MR-J4 servo amplifiers comply with category C3 in accordance with EN 61800-3. As for I/O wires (max. length 10 m. However, 3 m for STO cable for CN8.) and encoder cables (max. length 50 m), use shielded wires and ground the shields. Install an EMC filter and surge protector on the primary side of the servo amplifier. In addition, use a line noise filter for outputs of the servo amplifiers. The following shows recommended products.

EMC filter: Soshin Electric HF3000A-UN series, TF3000C-TX series, COSEL FTB series

Surge protector: Okaya Electric Industries RSPD series Line noise filter: Mitsubishi Electric FR-BIF

MR-J4 Series are not intended to be used on a low-voltage public network which supplies domestic premises; Radio frequency interference is expected if used on such a network. The installer shall provide a guide for Installation and use, including recommended mitigation devices. To avoid the risk of crosstalk to signal cables, the installation instructions shall either recommend that the power interface cable be segregated from signal cables.

2) For Declaration of Conformity (DoC)

Hereby, MITSUBISHI ELECTRIC EUROPE B.V. declares that the optional unit is in compliance with EC directives (EMC directive (2014/30/EU) and RoHS directive (2011/65/EU)). For the copy of Declaration of Conformity, contact your local sales office.

(c) USA/Canada compliance

This servo amplifier is designed in compliance with UL 508C and CSA C22.2 No. 14.

1) Installation

The minimum cabinet size is 150% of each MR-J4 servo amplifier's volume. Also, design the cabinet so that the ambient temperature in the cabinet is 55 °C or less. The servo amplifier must be installed in a metal cabinet. Additionally, mount the servo amplifier on a cabinet that the protective earth based on the standard of IEC/EN 60204-1 is correctly connected. For environment, the units should be used in open type (UL 50) and overvoltage category shown in table in section 10.2.8. The servo amplifier needs to be installed at or below pollution degree 2. Use only copper wires or copper bus bars for wiring.

2) Short-circuit current rating (SCCR)

Suitable For Use On A Circuit Capable Of Delivering Not More Than 100 kA rms Symmetrical Amperes, 500 Volts Maximum.

3) Overload protection characteristics

The MR-J4 servo amplifiers have servo motor overload protective function. (It is set on the basis (full load current) of 120% rated current of the servo amplifier.)

4) Over-temperature protection for motor

Motor Over temperature sensing is not provided by the drive.

Integral thermal protection(s) is necessary for motor and refer to section 10.2.8. for the proper connection.

10. APPENDIX

5) Branch circuit protection

For installation in United States, branch circuit protection must be provided, in accordance with the National Electrical Code and any applicable local codes.

For installation in Canada, branch circuit protection must be provided, in accordance with the Canada Electrical Code and any applicable provincial codes.

(d) South Korea compliance (MR-CR55K(4) and 30 kW or more of MR-J4-DU)

This product complies with the Radio Wave Law (KC mark) Please note the following to use the product.

이 기기는 업무용 (A급) 전자파적합기기로서 판매자 또는 사용자는 이 점을 주의하시기 바라며, 가정외의 지역에서 사용하는 것을 목적으로 합니다.

(The product is for business use (Class A) and meets the electromagnetic compatibility requirements. The seller and the user must note the above point, and use the product in a place except for home.)

In addition, use an EMC filter, surge protector, ferrite core, and line noise filter on the primary side for inputs. Use a ferrite core and line noise filter for outputs. Use a distance greater than 30 m between the product and third party sensitive radio communications.

(4) General cautions for safety protection and protective measures

Observe the following items to ensure proper use of the MR-J4 servo amplifiers.

(a) For safety components and installing systems, only qualified personnel and professional engineers should perform.

(b) When mounting, installing, and using the MR-J4 servo amplifier, always observe standards and directives applicable in the country.

(c) The item about noises of the test notices in the manuals should be observed.

(5) Residual risk

(a) Be sure that all safety related switches, relays, sensors, etc., meet the required safety standards.

(b) Perform all risk assessments and safety level certification to the machine or the system as a whole.

(c) If the upper and lower power modules in the servo amplifier are shorted and damaged simultaneously, the servo motor may make a half revolution at a maximum.

(d) Only qualified personnel are authorized to install, start-up, repair or adjust the machines in which these components are installed. Only trained engineers should install and operate the equipment. (ISO 13849-1 Table F.1 No. 5)

(e) Separate the wiring for safety observation function from other signal wirings. (ISO 13849-1 Table F.1 No. 1)

(f) Protect the cables with appropriate ways (routing them in a cabinet, using a cable guard, etc.).

(g) Keep the required clearance/creepage distance depending on voltage you use.

10. APPENDIX

(6) Disposal

Disposal of unusable or irreparable devices should always occur in accordance with the applicable country-specific waste disposal regulations. (Example: European Waste 16 02 14)

(7) Lithium battery transportation

To transport lithium batteries, take actions to comply with the instructions and regulations such as the United Nations (UN), the International Civil Aviation Organization (ICAO), and the International Maritime Organization (IMO).

The batteries (MR-BAT6V1SET, MR-BAT6V1, and MR-BAT6V1BJ) are assembled batteries from two batteries (lithium metal battery CR17335A) which are not subject to the dangerous goods (Class 9) of the UN Recommendations.

10.2.3 Installation direction and clearances



- The devices must be installed in the specified direction. Not doing so may cause a malfunction.
- Mount the servo amplifier on a cabinet which meets IP54 in the correct vertical direction to maintain pollution degree 2.

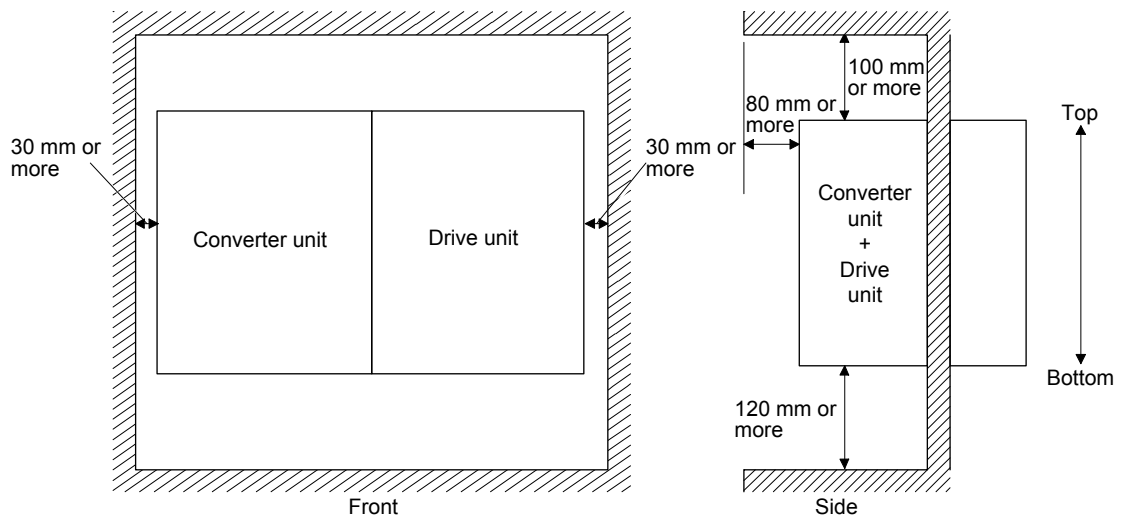

10. APPENDIX

10.2.4 Electrical Installation and configuration diagram



WARNING

- Turn off the molded-case circuit breaker (MCCB) to avoid electrical shocks or damages to the product before starting the installation or wiring.



CAUTION

- Securely connect the cables in the specified method and tighten them with the specified torque. Otherwise, the servo motor may operate unexpectedly.
- The installation complies with IEC/EN 60204-1. The voltage supply to machines must be 20 ms or more of tolerance against instantaneous power failure as specified in IEC/EN 60204-1.
- Connecting a servo motor of the wrong axis to U, V, W, or CN2_ of the servo amplifier may cause a malfunction.

10. APPENDIX

The following shows representative configuration examples to conform to the IEC/EN/UL/CSA standards.

Connection with resistance regeneration converter unit

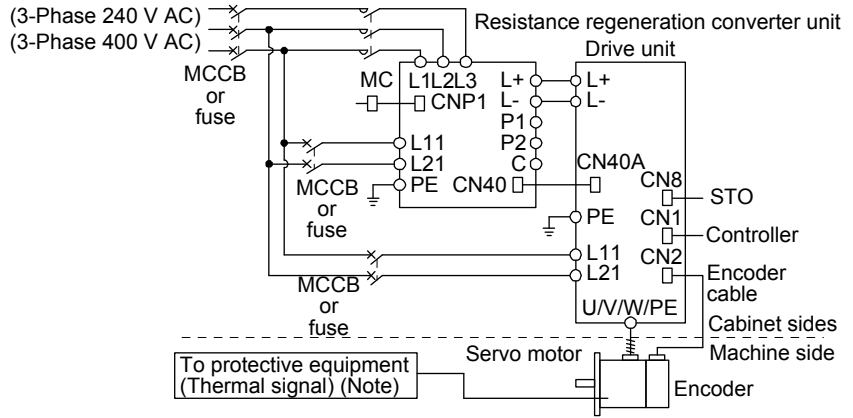

Connection with power regeneration converter unit

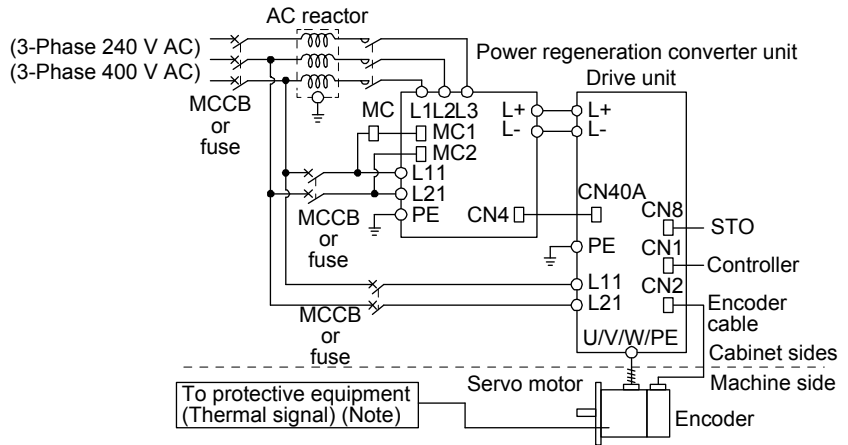

Note. Please use a thermal sensor, etc. for thermal protection of the servo motor.

The connectors described by rectangles are safely separated from the main circuits described by circles. The connected motors will be limited as follows.

- HG/HF/HC/HA series servo motors (Mfg.: Mitsubishi Electric)
- Using a servo motor complied with IEC 60034-1 and Mitsubishi Electric encoder (OBA, OSA)

10. APPENDIX

10.2.5 Signals

(1) Signal

The following shows MR-J4-DU30KB signals as a typical example.

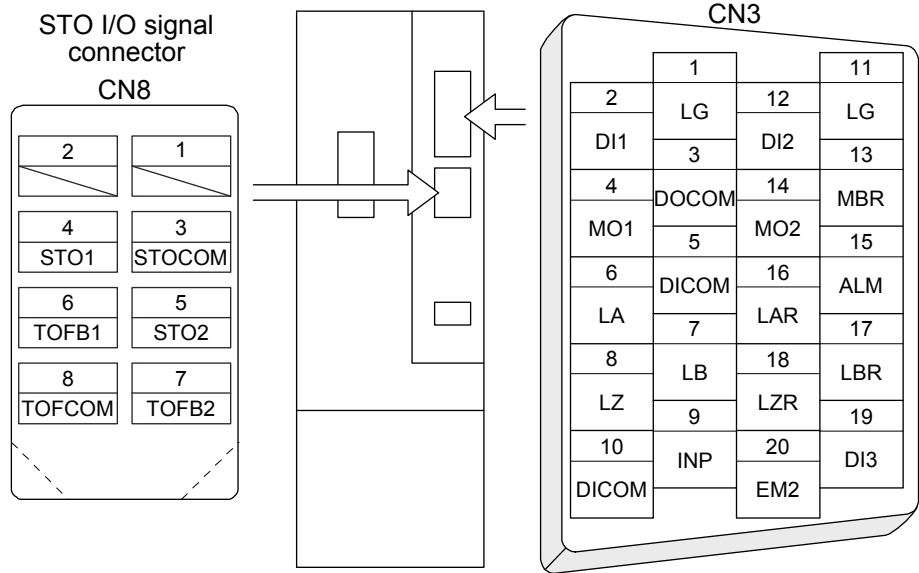

(2) I/O device

Input device

Symbol	Device	Connector	Pin No.
EM2	Forced stop 2	CN3	20
STOCOM	Common terminal for input signals STO1/STO2	CN8	3
STO1	STO1 state input		4
STO2	STO2 state input		5

Output device

Symbol	Device	Connector	Pin No.
TOFCOM	Common terminal for monitor output signal in STO state	CN8	8
TOFB1	Monitor output signal in STO1 state		6
TOFB2	Monitor output signal in STO2 state		7

Power supply

Symbol	Device	Connector	Pin No.
DICOM	Digital I/F power supply input	CN3	5, 10
DOCOM	Digital I/F common		3
SD	Shield		Plate

10. APPENDIX

10.2.6 Maintenance and service

	WARNING	● To avoid an electric shock, only qualified personnel should attempt inspections. For repair and parts replacement, contact your local sales office.
---	---------	--

(1) Inspection items

It is recommended that the following points periodically be checked.

(a) Check for loose terminal block screws. Retighten any loose screws.

Drive unit/converter unit	Tightening torque: [N•m]													
	L1	L2	L3	P1	P2	C	L+	L-	L11	L21	U	V	W	PE
MR-J4-DU700_/MR-J4-DU900_ MR-J4-DU11K_/MR-J4-DU15K_ MR-J4-DU22K_/MR-J4-DU700_4/ MR-J4-DU900_4/MR-J4-DU11K_4/ MR-J4-DU15K_4/MR-J4-DU22K_4/ MR-J4-DU30K_4/MR-J4-DU37K_4	/						3.0	1.2	6.0					
MR-J4-DU30K_/MR-J4-DU37K_ MR-J4-DU45K_4/MR-J4-DU55K_4									12.0					
MR-CV11K_/MR-CV18K_/MR-CV11K_4/ MR-CV18K_4	2.0			/			3.0	1.2	/			2.0		
MR-CV30K_/MR-CV37K_/MR-CV45K_ MR-CV30K_4/MR-CV37K_4/MR-CV45K_4/ MR-CV55K_4/MR-CV75K_4	6.0											6.0		
MR-CV55K	12.0			/			3.0	1.2	/			12.0		
MR-CR55K/MR-CR55K4	12.0											12.0		

(b) Check servo motor bearings, brake section, etc. for unusual noise.

(c) Check the cables and the like for scratches or cracks. Perform periodic inspection according to operating conditions.

(d) Check that the connectors are securely connected to the servo motor.

(e) Check that the wires are not coming out from the connector.

(f) Check for dust accumulation on the servo amplifier.

(g) Check for unusual noise generated from the servo amplifier.

(h) Check the servo motor shaft and coupling for connection.

(i) Make sure that the emergency stop circuit operates properly such that an operation can be stopped immediately and a power is shut off by the emergency stop switch.

10. APPENDIX

(2) Parts having service life

Service life of the following parts is listed below. However, the service life varies depending on operating methods and environment. If any fault is found in the parts, they must be replaced immediately regardless of their service life. For parts replacement, please contact your local sales office.

Part name	Life guideline
Smoothing capacitor	10 years (Note 3)
Relay	Number of power-on, forced stop and controller forced stop times: 100,000 times Number of on and off for STO: 100,000 times
Cooling fan	10,000 hours to 30,000 hours (2 years to 3 years)
Battery backup time (Note 1)	Approximately 20,000 hours (equipment power supply: off, ambient temperature: 20 °C)
Battery life (Note 2)	5 years from date of manufacture

- Note
1. The time is for using MR-J4 servo amplifier with a rotary servo motor using MR-BAT6V1SET or MR-BAT6V1BJ. For details and other battery backup time, refer to each servo amplifier instruction manual.
 2. Quality of the batteries degrades by the storage condition. The battery life is 5 years from the production date regardless of the connection status.
 3. The characteristic of smoothing capacitor is deteriorated due to ripple currents, etc. The life of the capacitor greatly depends on ambient temperature and operating conditions. The capacitor will be the end of its life in 10 years of continuous operation in air-conditioned environment (ambient temperature of 40 °C or less for use at the maximum 1000 m above sea level, 30 °C or less for over 1000 m to 2000 m).

10.2.7 Transportation and storage

 CAUTION	●Transport the products correctly according to their mass.
	●Stacking in excess of the limited number of product packages is not allowed.
	●For detailed information on transportation and handling of the battery, refer to the servo amplifier instruction manual.
	●Install the product in a load-bearing place of servo amplifier and servo motor in accordance with the instruction manual.
	●Do not put excessive load on the machine.
	●Do not hold the front cover, cables, or connectors when carrying the servo amplifier. Otherwise, it may drop.

When you keep or use it, please fulfill the following environment.

Item		Environment
Ambient temperature	Operation [°C]	0 to 55 Class 3K3 (IEC/EN 60721-3-3)
	Transportation (Note) [°C]	-20 to 65 Class 2K4 (IEC/EN 60721-3-2)
	Storage (Note) [°C]	-20 to 65 Class 1K4 (IEC/EN 60721-3-1)
Ambient humidity	Operation, transportation, storage	5 %RH to 90 %RH
Vibration resistance	Test condition	10 Hz to 57 Hz with constant amplitude of 0.075 mm 57 Hz to 150 Hz with constant acceleration of 9.8 m/s ² to IEC/EN 61800-5-1 (Test Fc of IEC 60068-2-6)
	Operation	5.9 m/s ²
	Transportation (Note)	Class 2M3 (IEC/EN 60721-3-2)
	Storage	Class 1M2 (IEC/EN 60721-3-2)
Pollution degree		2
IP rating		IP20 (IEC/EN 60529), Terminal block IP00 Open type (UL 50)
Altitude	Operation, storage	Max. 2000 m above sea level
	Transportation	Max. 10000 m above sea level

Note. In regular transport packaging

10. APPENDIX

10.2.8 Technical data

(1) Converter unit

Item		MR_														
		CR_		CV_						CR_		CV_				
		55K	11K	18K	30K	37K	45K	55K	55K4	11K4	18K4	30K4	37K4	45K4	55K4	75K4
Output	Rated voltage	270 V DC to 324 V DC							513 V DC to 648 V DC							
	Rated current [A]	215.9	41	76	144	164	198	238	113.8	21	38	72	82	99	119	150
Power supply	Main circuit (line voltage)	Voltage, Frequency	3-phase 200 V AC to 240 V AC, 50 Hz/60 Hz							3-phase 380 V AC to 480 V AC, 50 Hz/60 Hz						
		Current [A]	191.3	35	65	107	121	148	200	100.7	18	35	61	70	85	106
	Control circuit (line voltage)	1-phase 200 V AC to 240 V AC, 50 Hz/60 Hz, 0.3 A							1-phase 380 V AC to 480 V AC, 50 Hz/60 Hz, 0.2 A							
Interface (SELV)		24 V DC ± 10% (required current capacity: MR-CR_, 150 mA; MR-CV_, 350 mA)														
Pollution degree		2 (IEC/EN 60664-1)														
Overvoltage category		3-phase 200 V AC/400 V AC: III (IEC/EN 60664-1)														
Protective class		I (IEC/EN 61800-5-1)														
Short-circuit current rating (SCCR)		100 kA														

(2) Drive unit

Item		MR-J4-DU_														
		700_	900_	11K_	15K_	22K_	30K_	37K_	700_4	900_4	11K_4	15K_4	22K_4	30K_4	37K_4	45K_4
Output	Rated voltage	3-phase 170 V AC, 360 Hz							3-phase 323 V AC, 360 Hz							
	Rated current [A]	37	54	68	87	126	174	204	17	25	32	41	63	87	102	131
Power supply	Main circuit	The main circuit power of the drive unit is supplied by the converter unit.														
	Control circuit (line voltage)	1-phase 200 V AC to 240 V AC, 50 Hz/60 Hz, 0.3 A							1-phase 380 V AC to 480 V AC, 50 Hz/60 Hz, 0.2 A							
	Interface (SELV)	24 V DC ± 10% (required current capacity: MR-J4-DU_A_, 500 mA; MR-J4-DU_B_, 300 mA)														
Control method		Sine-wave PWM control, current control method														
Safety observation function (STO) IEC/EN 61800-5-2 (Note)		EN ISO 13849-1 category 3 PL e, IEC 61508 SIL 3, EN 62061 SIL CL 3, and EN 61800-5-2														
Mean time to dangerous failure		MTTFd ≥ 100 [years] (314a)														
Effectiveness of fault monitoring of a system or subsystem		DC = Medium, 97.6 [%]														
Probability of dangerous Failure per Hour		PFH = 6.4 × 10 ⁻⁹ [1/h]														
Mission time		TM = 20 [years]														
Response performance		8 ms or less (STO input off → energy shut off)														
Pollution degree		2 (IEC/EN 60664-1)														
Overvoltage category		3-phase 200 V AC/400 V AC: III (IEC/EN 60664-1)														
Protective class		I (IEC/EN 61800-5-1)														
Short-circuit current rating (SCCR)		100 kA														

Note. Servo amplifiers manufactured in August 2015 or later comply with SIL 3 requirements.

10. APPENDIX

(3) Dimensions/mounting hole process drawing

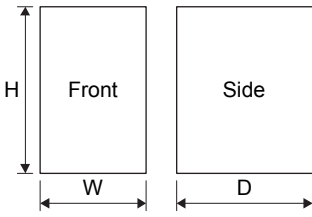

Converter unit/drive unit	Variable dimensions [mm]			Mass [kg]
	W	H	D	
MR-CR55K/MR-CR55K4	300	380	300	22
MR-CV11K/MR-CV18K/ MR-CV11K4/MR-CV18K4	90	380	270	7.0
MR-CV30K/MR-CV37K/MR-CV45K/ MR-CV30K4/MR-CV37K4/MR-CV45K4	150	380	300	10.7
MR-CV55K/MR-CV55K4/MR-CV75K4	300	380	300	26.5
MR-J4-DU700_/MR-J4-DU900_ MR-J4-DU11K_/MR-J4-DU700_4/ MR-J4-DU900_4/MR-J4-DU11K_4	150	380	300	9.9
MR-J4-DU15K_/MR-J4-DU22K_ MR-J4-DU15K_4_/MR-J4-DU22K_4	240	380	300	15.2
MR-J4-DU30K_/MR-J4-DU37K_	300	380	300	21
MR-J4-DU30K_4/MR-J4-DU37K_4	240	380	300	16
MR-J4-DU45K_4/MR-J4-DU55K_4	300	380	300	19

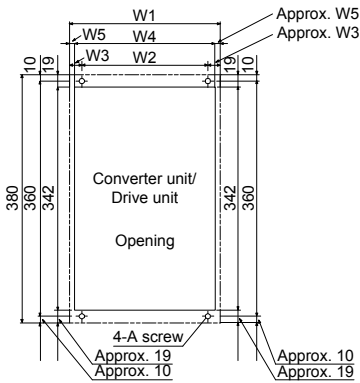

Converter unit/Drive unit	Variable dimensions [mm]					Screw size A
	W1	W2	W3	W4	W5	
MR-CR55K/MR-CR55K4/ MR-J4-DU30K_/MR-J4-DU37K_ MR-J4-DU45K_4/MR-J4-DU55K_4	300	260	20	281	9.5	M6
MR-CV11K/MR-CV18K/MR-CV11K4/ MR-CV18K4	90	-	45	82	4	M5
MR-CV30K/MR-CV37K/MR-CV45K/ MR-CV30K4/MR-CV37K4/ MR-CV45K4/MR-J4-DU700_ MR-J4-DU900_/MR-J4-DU11K_ MR-J4-DU700_4/MR-J4-DU900_4/ MR-J4-DU11K_4	150	60	45	142	4	M5
MR-CV55K/MR-CV55K4/MR-CV75K4	300	180	60	282	9	M5
MR-J4-DU15K_/MR-J4-DU22K_ MR-J4-DU15K_4/MR-J4-DU22K_4/ MR-J4-DU30K_4/MR-J4-DU37K_4	240	120	60	222	9	M5

10.2.9 Check list for user documentation



MR-CV/MR-CR/MR-J4-DU installation checklist for manufacturer/installer

The following items must be satisfied by the initial test operation at least. The manufacturer/installer must be responsible for checking the standards in the items.

Maintain and keep this checklist with related documents of machines to use this for periodic inspection.

1. Is it based on directive/standard applied to the machine? Yes [], No []
2. Is directive/standard contained in Declaration of Conformity (DoC)? Yes [], No []
3. Does the protection instrument conform to the category required? Yes [], No []
4. Are electric shock protective measures (protective class) effective? Yes [], No []
5. Is the STO function checked (test of all the shut-off wiring)? Yes [], No []

Checking the items will not be instead of the first test operation or periodic inspection by professional engineers.

10. APPENDIX

10.3 Special coating-specification product (IEC 60721-3-3 Class 3C2)

10.3.1 Summary

This section explains servo amplifiers with a special coating specification.

10.3.2 Specifications

(1) Special coating

Using the MR-J4 series in an atmosphere containing a corrosive gas may cause its corrosion with time, resulting in a malfunction. For the printed circuit board of the servo amplifiers with a special coating specification, a urethane coating agent is applied to some parts capable of being coated technically (except LEDs, connectors, terminal blocks, etc.) to improve the resistance to corrosive gases. Use a servo amplifier with a special coating specification specifically for applications susceptible to corrosive gases, including tire manufacturing and water treatment. Although the special coating-specification products have the improved resistance to corrosive gases, proper operations in environments mentioned above are not guaranteed. Therefore, perform periodic inspections for any abnormality.

(2) Standard for corrosive gases

In IEC 60721-3-3, corrosive gases refer to sea salt, sulfur dioxide, hydrogen sulfide, chlorine, hydrogen chloride, hydrogen fluoride, ammonia, ozone, and nitrogen oxides shown in the environmental parameter column of the table below.

The table also shows the corrosive gas concentrations defined in IEC 60721-3-3, Class 3C2.



Environmental parameter	Unit	3C2	
		Mean value	Maximum value
a) Sea salt	None	Salt mist	
b) Sulfur dioxide	cm ³ /m ³	0.11	0.37
c) Hydrogen sulfide	cm ³ /m ³	0.071	0.36
d) Chlorine	cm ³ /m ³	0.034	0.1
e) Hydrogen chloride	cm ³ /m ³	0.066	0.33
f) Hydrogen fluoride	cm ³ /m ³	0.012	0.036
g) Ammonia	cm ³ /m ³	1.4	4.2
h) Ozone	cm ³ /m ³	0.025	0.05
i) Nitrogen oxides	cm ³ /m ³	0.26	0.52

The special coating-specification products have the improved corrosion resistance in environments with corrosive gas concentrations conforming to IEC 60721-3-3, Class 3C2. We tested typical models and confirmed that their corrosive gas resistance was improved, compared with the standard models.

10. APPENDIX

10.4 EC declaration of conformity

The MR-J4-_DU series drive units comply with the safety component laid down in the Machinery directive.

ZERTIFIKAT ◆ CERTIFICATE ◆ 認 証 証 書 ◆ CERTIFICADO ◆ CERTIFICAT	 Product Service
	CERTIFICATE
	No. Z10 16 08 66509 026
	Holder of Certificate: MITSUBISHI ELECTRIC CORPORATION Nagoya Works 5-1-14, Yada-Minami Higashi-ku, Nagoya-shi Aichi 461-8670 JAPAN
	Factory(ies): 66509, 83304
	Certification Mark: 
	Product: AC servo systems
	Model(s): Drive Unit MR-J4 Series Drive Unit MR-JE Series For nomenclature see attachment
	Parameters: Safety function (EN 61800-5-2): STO Ambient temperature: 0°C to 55°C Operation: -20°C to 65°C Storage: max. 2000m above sea level Altitude:
	Tested according to: EN ISO 13849-1:2015 (Cat 3, PL e) EN 62061:2005/A2:2015 (SILCL 3) IEC 62061(ed.1);am1;am2 IEC 61508-1(ed.2) (SIL 3) IEC 61508-2(ed.2) (SIL 3) IEC 61508-4(ed.2) (SIL 3) EN 61800-5-1:2007 IEC 61800-5-1(ed.2) EN 61800-5-2:2007 IEC 61800-5-2(ed.2) IEC 61326-3-1(ed.1)

The product was tested on a voluntary basis and complies with the essential requirements. The certification mark shown above can be affixed on the product. It is not permitted to alter the certification mark in any way. In addition the certification holder must not transfer the certificate to third parties. See also notes overleaf.

Test report no.:	MN86533T
Valid until:	2021-08-24

Date, 2016-08-25

(Günter Greil)

Page 1 of 3



TÜV SÜD Product Service GmbH · Zertifizierstelle · Ridlerstraße 65 · 80339 München · Germany 

10. APPENDIX

10.5 Status of general-purpose AC servo products for compliance with the China RoHS directive





10.5.1 Summary

The China RoHS directive: 电子信息产品污染控制管理办法 (Management Methods for Controlling Pollution by Electronic Information Products) came into effect on March 1, 2007. The China RoHS directive was replaced by the following China RoHS directive: 电器电子产品有害物质限制使用管理办法 (Management Methods for the Restriction of the Use of Hazardous Substances in Electrical and Electronic Products). The succeeding China RoHS directive has been in effect since July 1, 2016.

The China RoHS directive restricts the use of six hazardous substances (lead, mercury, cadmium, hexavalent chromium, polybrominated biphenyls (PBB), and polybrominated diphenyl ethers (PBDE)) and other hazardous substances specified by the State (currently no applicable substances). The EU RoHS directive (2011/65/EU) also restricts the use of the above six hazardous substances.

10.5.2 Status of our products for compliance with the China RoHS directive

The following tables show the content of six hazardous substances in our products and Environment-Friendly Use Period marks. This table is created based on the standard SJ/T11364.

Part name	Substance name Threshold standard	Hazardous substance (Note 1)						Environment-Friendly Use Period mark (Note 2)	Remark
		Lead (Pb)	Mercury (Hg)	Cadmium (Cd)	Hexavalent chromium (Cr(VI))	PBB	PBDE		
		Threshold of cadmium: 0.01 wt% (100 ppm), Threshold of substances other than cadmium: 0.1 wt% (1000 ppm)							
Servo amplifier	Mounting board	×	○	○	○	○	○		/
	Servo system controller	Heat sink	×	○	○	○	○		
	Resin cabinet	○	○	○	○	○	○		
	Plate and screw	○	○	○	○	○	○		
Servo motor	Bracket	×	○	○	○	○	○		/
	Mounting board	×	○	○	○	○	○		
	Resin cabinet	○	○	○	○	○	○		
	Core and cable	○	○	○	○	○	○		
Cable product	Cable	○	○	○	○	○	○		Including connector set
	Connector	○	○	○	○	○	○		
Optional unit	Mounting board	×	○	○	○	○	○		/
	Resin cabinet	○	○	○	○	○	○		
	Plate and screw	○	○	○	○	○	○		

Note 1. ○: Indicates that said hazardous substance contained in all of the homogeneous materials for this part is below the limit requirement of GB/T26572.

×: Indicates that said hazardous substance contained in at least one of the homogeneous materials for this part is above the limit requirement of GB/T26572.

2. Indications based on "Marking for the restriction of the use of hazardous substances in electrical and electronic product" [SJ/T11364-2014]



Indicates that a certain hazardous substance is contained in the product manufactured or sold in China. Observe safety and usage precautions for the product, and use it within a limited number of years from the production date. Thereby, any of the hazardous substances in the product does not cause environmental pollution, or seriously affect human health or property.



Indicates that no certain hazardous substance is contained in the product.

10. APPENDIX

10.5.3 Difference between the China RoHS directive and the EU RoHS directive

The China RoHS directive allows no restriction exemption unlike the EU RoHS directive. Although a product complies with the EU RoHS directive, a hazardous substance in the product may be considered to be above the limit requirement (marked "x") in the China RoHS directive.

The following shows some restriction exemptions and their examples according to the EU RoHS directive.

- Lead as an alloying element in steel for machining purposes and in galvanized steel containing up to 0.35% lead by weight, lead as an alloying element in aluminum containing up to 0.4% lead by weight, and copper alloy containing up to 4% lead by weight, e.g. brass-made insert nuts
- Lead in high melting temperature type solders (i.e. lead-based alloys containing 85% by weight or more lead)
- Electrical and electronic components containing lead in a glass or ceramic other than dielectric ceramic in capacitors, e.g. piezoelectric devices
- Electrical and electronic components containing lead in a glass or ceramic matrix compound, e.g. chip resistors

10.5.4 Status of our products for compliance with the China RoHS directive (Chinese)

The following shows the table in Chinese according to "Management Methods for the Restriction of the Use of Hazardous Substances in Electrical and Electronic Products".

部件名称	物质名称 限值 基准	有害物质 (注1)						环境保护 使用期限标识 (注2)	备注
		铅 (Pb)	汞 (Hg)	镉 (Cd)	六价铬 (Cr(VI))	PBB	PBDE		
		阈值: 镉: 0.01wt%(100ppm)、 镉以外: 0.1wt%(1000ppm)、							
伺服放大器 伺服系统 控制器	电路板组件	x	○	○	○	○	○		/
	散热片	x	○	○	○	○	○		
	树脂壳体	○	○	○	○	○	○		
	金属板、螺丝	○	○	○	○	○	○		
伺服电机	托架	x	○	○	○	○	○		/
	电路板组件	x	○	○	○	○	○		
	树脂壳体	○	○	○	○	○	○		
	铁心、电线	○	○	○	○	○	○		
电缆 加工品	电线	○	○	○	○	○	○		包括连接器组件
	连接器	○	○	○	○	○	○		
选件 模块	电路板组件	x	○	○	○	○	○		/
	树脂壳体	○	○	○	○	○	○		
	金属板、螺丝	○	○	○	○	○	○		

- 注 1. ○: 表示该有害物质在该部件所有均质材料中的含量均在GB/T26572规定的限量要求以下。
x: 表示该有害物质在该部件的至少一种均质材料中的含量超出GB/T26572规定的限量要求。
2. 根据“电子电气产品有害物质限制使用标识要求”、[SJ/T11364-2014]的表示



该标志表示在中国制造/销售的产品中含有特定有害物质。

只要遵守本产品的安全及使用方面的注意事项，从生产日算起的环保使用期限内不会造成环境污染或对人体、财产产生深刻的影响。



该标志表示制造的产品中不含有特定有害物质。

REVISION

*The manual number is given on the bottom left of the back cover.

Print Data	*Manual Number	Revision
Jan. 2015	SH(NA)030153ENG-A	First edition
Aug. 2015	SH(NA)030153ENG-B	<p>Altitude of 2000 m above sea level is disclosed.</p> <p>Safety Instructions</p> <p>4. Additional instructions The environment is changed.</p> <p>Relevant manuals The part of table is changed.</p> <p>Section 1.1.1 The diagram is partially changed.</p> <p>Section 1.1 The note is partially changed.</p> <p>Section 1.2.1 The part of table is changed.</p> <p>Section 1.2.2 (1) (a) The table and the note are partially changed.</p> <p>Section 1.2.2 (1) (b) The table and the note are partially changed.</p> <p>Section 1.2.2 (2) (a) The table and the note are partially changed.</p> <p>Section 1.2.2 (2) (b) The table and the note are partially changed.</p> <p>Section 1.4 (2) (b) The diagram is changed.</p> <p>Section 1.5.1 (1) The part of table is changed.</p> <p>Section 1.5.1 (2) (a) 1) a) The part of table is changed.</p> <p>Section 1.5.1 (2) (a) 2) a) The part of table is changed.</p> <p>Section 1.6 The note is changed.</p> <p>Section 2.5 Added.</p> <p>Section 3.1.2 (1) (a) The note is partially changed.</p> <p>Section 3.1.2 (1) (b) The note is partially changed.</p> <p>Section 3.1.2 (2) (a) The note is partially changed.</p> <p>Section 3.1.2 (2) (b) The note is partially changed.</p> <p>Section 3.3.2 (1) The diagram is partially changed.</p> <p>Section 6.2 The sentences are partially changed.</p> <p>Section 6.2.1 (2) The sentences are partially changed.</p> <p>Section 6.2.2 The table and the note are partially changed.</p> <p>Section 6.2.3 The part of table is changed.</p> <p>Section 9.3.2 The note is partially changed.</p> <p>Section 9.5 (1) The caution and the note are added.</p> <p>Section 9.5 (2) The sentences are changed.</p> <p>Section 9.10.3 (1) (a) The note is partially changed.</p> <p>Section 9.10.3 (1) (b) The note is partially changed.</p> <p>Section 9.10.3 (2) (a) 1) The note is partially changed.</p> <p>Section 9.10.3 (2) (a) 2) The note is partially changed.</p> <p>Section 9.10.3 (2) (b) 1) The note is partially changed.</p> <p>Section 9.10.3 (2) (b) 2) The note is partially changed.</p> <p>Section 9.10.3 (3) The diagram is partially changed.</p> <p>App. 2 Partially changed.</p>
Feb. 2017	SH(NA)030153ENG-C	<p>MR-CV_ is added.</p> <p>MR-J4-DU900B_ to MR-J4-DU22KB_ are added.</p> <p>MR-D30 is supported.</p> <p>MR-CR55_ and MR-J4-DU_ with a special coating specification are added.</p> <p>Safety Instructions</p> <p>4. Additional instructions The environment is changed.</p> <p>Relevant manuals The part of table is changed.</p> <p>Chapter 1 to Chapter 9 The contents are entirely changed.</p> <p>App. 3 Added.</p> <p>App. 4 Added.</p> <p>App. 5 Added.</p>
May 2017	SH(NA)030153ENG-D	<p>Maximally increased torque function for MR-J4-DU900B is added.</p> <p>4. Additional instructions</p> <p>(3) Sentences in test run and adjustment are changed.</p> <p>Section 1.1 The part of table is changed.</p>

Print Data	*Manual Number	Revision	
May 2017	SH(NA)030153ENG-D	Section 1.3.3 Section 1.4.1 (2) Section 1.4.3 (1) Section 1.6.1 Section 3.1 Section 3.3.1 (2) Section 3.3.4 (1) Section 3.6 Section 5.1 (1) (a) Section 5.3.1 Section 5.4.1 Section 6.1.1 (2) Section 6.1.2 (2) Section 6.2.1 (2) Section 6.2.2 (2) Section 6.3.1 (2) Section 8.3.1 Section 8.3.2 Section 8.5 (1) App.2.3	The part of table is changed. The part of table is changed. The part of table is changed. Note 8 is added. Note 4 is added. Note 1 is changed. Sentences in RDYB (Operation permission) are changed. Note 1 is changed. Note 2 is changed. PC23 is added. Note 3 is changed. The sentences and table are changed. Note 2 is changed. The sentences and table are changed. Note 2 is changed. The sentences and table are changed. The table is changed. Note 8 is added and changed. Changed note 3 for the table of MR-CR_ The item name is changed.
Jun. 2018	SH(NA)030153ENG-E	The passing wiring of the control circuit power supply is added. 3. To prevent injury, note the following 4. Additional instructions Section 1.6 2. INSTALLATION Section 3.3.1 (2) Section 3.3.3 (2) Section 3.4 Section 4.3.1 (2) Section 5.1.1 (1) (a) Section 5.1.1 (1) (c) Section 5.1.1 (2) (a) Section 5.1.1 (2) (c) Section 5.1.2 (1) (a) Section 5.1.2 (2) (a) Section 5.1.1 (2) (c) Section 5.2 Section 5.4.2 Section 5.4.3 (1) Section 5.4.3 (2) Section 5.5 Section 8.2.2 (1) Section 8.3 Section 8.3.2 Section 8.4.2 Section 8.5.2 (3) Section 8.11.3 Section 8.11.4 Section 10.2.2 (1) (b) Section 10.2.7	The sentences are added. The sentences are added and changed. Note is added. CAUTION is added. Note is added. Added. Caution and Note are added. Note is added. The sentences in the table are partially deleted. The sentences in the table are partially deleted. The sentences in the table are partially deleted. The sentences in the table are partially deleted. The sentences in the table are partially deleted. The sentences in the table are partially deleted. The sentences in the table are partially deleted. CAUTION is added. CAUTION is added. The sentences are changed. The sentences are changed. Added. The contents are entirely changed. POINT is changed. Note is added. Added. Added. POINT is added. POINT is added. The sentences are changed. CAUTION is added.

This manual confers no industrial property rights or any rights of any other kind, nor does it confer any patent licenses. Mitsubishi Electric Corporation cannot be held responsible for any problems involving industrial property rights which may occur as a result of using the contents noted in this manual.

MELSERVO is a trademark or registered trademark of Mitsubishi Electric Corporation in Japan and/or other countries.
All other product names and company names are trademarks or registered trademarks of their respective companies.

Warranty

1. Warranty period and coverage

We will repair any failure or defect hereinafter referred to as "failure" in our FA equipment hereinafter referred to as the "Product" arisen during warranty period at no charge due to causes for which we are responsible through the distributor from which you purchased the Product or our service provider. However, we will charge the actual cost of dispatching our engineer for an on-site repair work on request by customer in Japan or overseas countries. We are not responsible for any on-site readjustment and/or trial run that may be required after a defective unit are repaired or replaced.

[Term]

The term of warranty for Product is twelve (12) months after your purchase or delivery of the Product to a place designated by you or eighteen (18) months from the date of manufacture whichever comes first ("Warranty Period"). Warranty period for repaired Product cannot exceed beyond the original warranty period before any repair work.

[Limitations]

- (1) You are requested to conduct an initial failure diagnosis by yourself, as a general rule.
It can also be carried out by us or our service company upon your request and the actual cost will be charged. However, it will not be charged if we are responsible for the cause of the failure.
- (2) This limited warranty applies only when the condition, method, environment, etc. of use are in compliance with the terms and conditions and instructions that are set forth in the instruction manual and user manual for the Product and the caution label affixed to the Product.
- (3) Even during the term of warranty, the repair cost will be charged on you in the following cases;
 - (i) a failure caused by your improper storing or handling, carelessness or negligence, etc., and a failure caused by your hardware or software problem
 - (ii) a failure caused by any alteration, etc. to the Product made on your side without our approval
 - (iii) a failure which may be regarded as avoidable, if your equipment in which the Product is incorporated is equipped with a safety device required by applicable laws and has any function or structure considered to be indispensable according to a common sense in the industry
 - (iv) a failure which may be regarded as avoidable if consumable parts designated in the instruction manual, etc. are duly maintained and replaced
 - (v) any replacement of consumable parts (battery, fan, smoothing capacitor, etc.)
 - (vi) a failure caused by external factors such as inevitable accidents, including without limitation fire and abnormal fluctuation of voltage, and acts of God, including without limitation earthquake, lightning and natural disasters
 - (vii) a failure generated by an unforeseeable cause with a scientific technology that was not available at the time of the shipment of the Product from our company
 - (viii) any other failures which we are not responsible for or which you acknowledge we are not responsible for

2. Term of warranty after the stop of production

- (1) We may accept the repair at charge for another seven (7) years after the production of the product is discontinued. The announcement of the stop of production for each model can be seen in our Sales and Service, etc.
- (2) Please note that the Product (including its spare parts) cannot be ordered after its stop of production.

3. Service in overseas countries

Our regional FA Center in overseas countries will accept the repair work of the Product. However, the terms and conditions of the repair work may differ depending on each FA Center. Please ask your local FA center for details.

4. Exclusion of loss in opportunity and secondary loss from warranty liability

Regardless of the gratis warranty term, Mitsubishi shall not be liable for compensation to:

- (1) Damages caused by any cause found not to be the responsibility of Mitsubishi.
- (2) Loss in opportunity, lost profits incurred to the user by Failures of Mitsubishi products.
- (3) Special damages and secondary damages whether foreseeable or not, compensation for accidents, and compensation for damages to products other than Mitsubishi products.
- (4) Replacement by the user, maintenance of on-site equipment, start-up test run and other tasks.

5. Change of Product specifications

Specifications listed in our catalogs, manuals or technical documents may be changed without notice.

6. Application and use of the Product

- (1) For the use of our General-Purpose AC Servo, its applications should be those that may not result in a serious damage even if any failure or malfunction occurs in General-Purpose AC Servo, and a backup or fail-safe function should operate on an external system to General-Purpose AC Servo when any failure or malfunction occurs.
- (2) Our General-Purpose AC Servo is designed and manufactured as a general purpose product for use at general industries. Therefore, applications substantially influential on the public interest for such as atomic power plants and other power plants of electric power companies, and also which require a special quality assurance system, including applications for railway companies and government or public offices are not recommended, and we assume no responsibility for any failure caused by these applications when used.
In addition, applications which may be substantially influential to human lives or properties for such as airlines, medical treatments, railway service, incineration and fuel systems, man-operated material handling equipment, entertainment machines, safety machines, etc. are not recommended, and we assume no responsibility for any failure caused by these applications when used. We will review the acceptability of the abovementioned applications, if you agree not to require a specific quality for a specific application. Please contact us for consultation.

MODEL	MR-J4-DU-(RJ)MR-CR-55K INSTRUCTIONMANUAL
MODEL CODE	1CW851

MITSUBISHI ELECTRIC CORPORATION

HEAD OFFICE: TOKYO BLDG MARUNOUCHI TOKYO 100-8310